

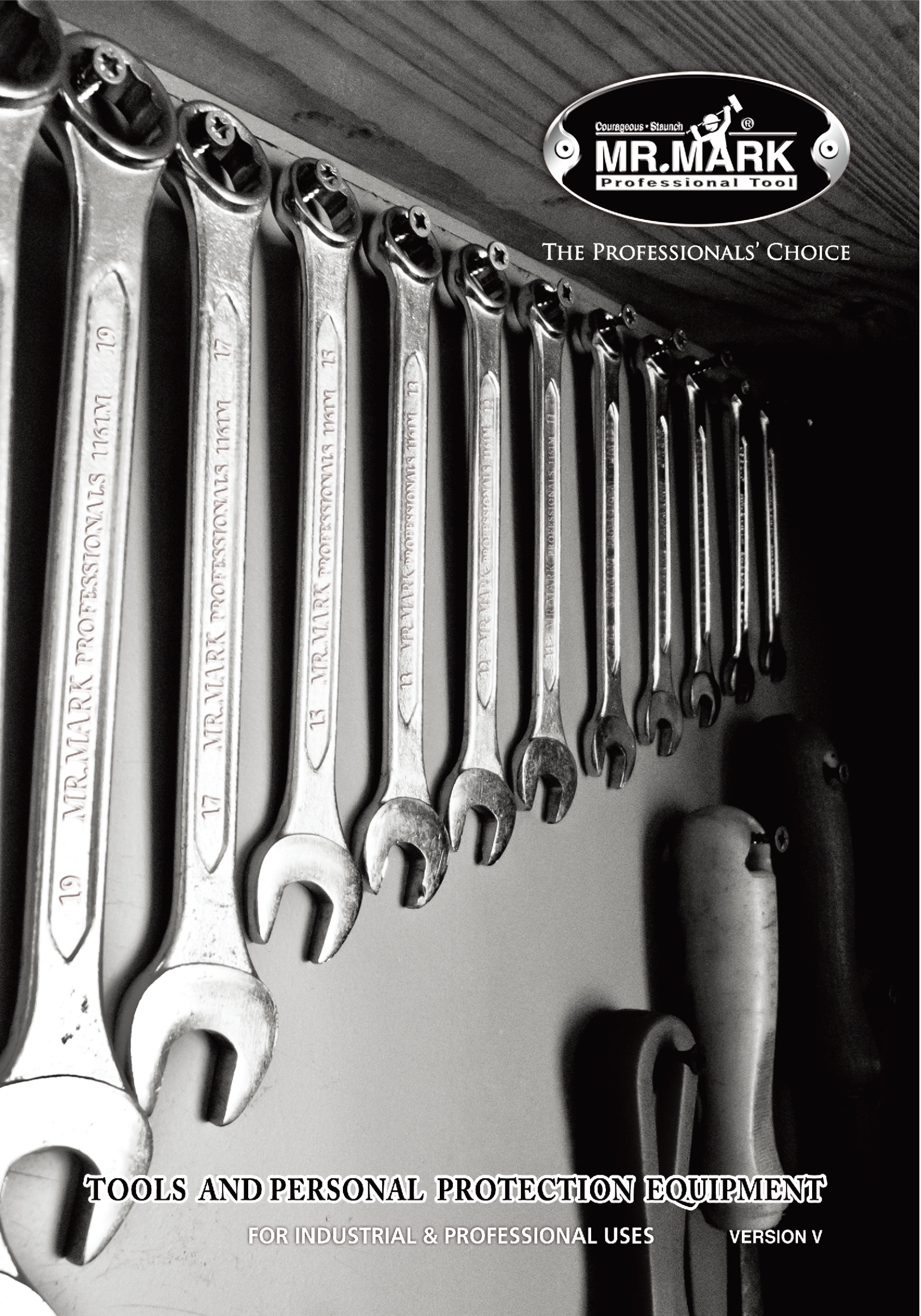

THE PROFESSIONALS' CHOICE



TOOLS AND PERSONAL PROTECTION EQUIPMENT

FOR INDUSTRIAL & PROFESSIONAL USES

VERSION V



THE PROFESSIONALS' CHOICE



SAFETY FIRST !!
MR. MARK



MANDATORY EAR PROTECTION



MANDATORY FACE SHIELD



MANDATORY MASK



MANDATORY PROTECTIVE GLOVES



MANDATORY RESPIRATOR



RISK OF EXPLOSION



MANDATORY PROTECTIVE CLOTHING



MUST READ INSTRUCTIONS BEFORE USE



OVERHEAD/OVERLOAD HAZARD

www.mrmarks.com

The GOAL of MR.MARK-**SAFETY FIRST !!**

The goal of Mr. Mark is to product tools that help you work safely and efficiently. The Most important safety environment is depending on YOU, consideration are the best protection against injury, All possible hazards cannot be covered here, but we have tried to highlight some of the important ones.



THIS SYMBOL INDICATES A HAZARD ALERT



THIS SYMBOL INDICATES PROHIBITED



AUTHORIZED PERSONNEL ONLY IN LIFT AREA



READ OPERATING AND SAFETY MANUALS BEFORE USING LIFT!



RISK OF ELECTRIC SHOCK



KEEP CHILDREN AWAY



DO NOT SPRAY WATER DIRECTLY ONTO LIFT



PROPER MAINTENANCE AND INSPECTION ARE NECESSARY FOR SAFE OPERATION!



RISK OF EXPLOSION



NO HAMMERING



DO NOT PLACE FEET UNDER ANY MOVING PART OF LIFT WHILE LOWERING



USE HEIGHT EXTENDERS (TRUCK ADAPTERS) WHEN NECESSARY TO ENSURE GOOD CONTACT



RISK OF FIRE



DO NOT OPEN MULTIPLE DRAWERS



STOP RAISING LIFT WHEN IMBALANCE IS DETECTED WHILE RASING VEHICLE



DO NOT OPERATE A DAMAGED LIFT!



VIBRATION HAZARD



NO IMPACT/POWER DRIVE



ALWAYS USE SAFETY STANDS WHEN REMOVING OR INSTALLING HEAVY COMPONENTS.



DO NOT OPERATE LIFT WHEN HYDRAULIC OIL LEAK IS DETECTED IN THE LIFT AREA



RISK OF ENTANGLEMENT



DO NOT PULL TO MOVE



DO NOT OPERATE A LIFT WITH PEOPLE ON IT.



LIFT TO BE USED BY TRAINED OPERATOR ONLY!



DO NOT OVERTORQUE NO PIPES OR LEVER



DO NOT STEP IN OR ON DRAWERS



ELECTRICAL SHOCK MAY OCCUR WHEN OPENING CONTROL BOX.



DO NOT MODIFY ANY SAFETY SYSTEMS OF HOIST. (IF SAFETY DEVICE MALFUNCTIONS, SERIOUS ACCIDENT MAY OCCUR.)



DO NOT STRIKE HARD OBJECTS



DO NOT PLACE ANY POLES UNDER THE VEHICLE AND LOWER IT TO DISMANTLE THE PART FROM THE RAISED VEHICLE



DO NOT STAND UNDER THE VEHICLE ON THE LIFT WHILE LIFT IS OPERATING. (DEATH OR SERIOUS INJURY MAY OCCUR.)



USE VEHICLE MANUFACTURER'S LIFT POINTS



NO PRYING



DO NOT SHAKE A RAISED VEHICLE EXCESSIVELY (DANGER OF VEHICLE FALLING FROM LIFT MAY OCCUR)



DO NOT LIFT ONE SIDE OF THE VEHICLE. (POSSIBILITY OF VEHICLE OVERTURN AND/OR DAMAGE TO LIFT MAY HAPPEN.)



IN THE EVENT OF RAISED VEHICLE FALLS FROM THE LIFT, RUN AWAY TO A SAFE DISTANCE

TECHNICAL SPECIFICATIONS



Do not use extensions to increase the applied torque (especially on general wrenches).



Do not use any tool as a lever, chisel or punch if not designed to (e.g. screwdrivers).



Do not strike tools to increase transmitted power if not designed for this use (e.g. wrenches and screwdrivers).



Do not use striking tools on surfaces harder than the striking face (e.g. hammers).



Do not modify products (structure or part).



Do not use metric wrenches on imperial bolts and vice versa.



Do not use worn out or damaged tools.



Do not strike hand tools.



Strictly no impact or power.



Do not drive tools incorrectly positioned.



WARNING - LOW TORQUE
Wrong application of these tools may result in damaged and injury.
Non warranty item.

★★★★★ SAFETY GUIDELINES ★★★★★



- Compressed air may cause injuries. Due to this, care must be taken that the compressed air and exhaust air is never pointed at the user or other people.
- Before using a pneumatic tool, please check that all couplings and plugs are secure. Airhoses that are under pressure may lash out when disconnected and could lead to serious injuries.
- After use or before changing accessories please unplug the tool from the airhose and release pressure.
- Never exceed the maximum pressures listed in the owners manuals, due to the fact that it leads to rapid wearing of the tool and can cause injuries to the users.



- Please use correct breathing protection when dust appears while working.



- Protective goggles should be worn to protect eyes.



- Please keep a safe distance between yourself and all moving parts.



- Please use the ear protection when high decibel noise occurred.



- Strong vibrations may lead to feelings of numbness.
- Wear protective gloves.



- Please make sure that there are no trailing hoses or wires within the working area, as this may lead to accidents.
- Always wear safety shoe.

Courageous · Staunch

MR. MARK
Professional Tool

CONTENTS

 DISPLAY STAND, TOOL CHEST, TOOL BOXES, TROLLEY AND ASSORTMENTS AND ASSORTMENTS	001 - 009
 TOOL KITS	010 - 022
 PNEUMATIC TOOLS	023 - 033
 HYDRAULIC JACKS, BOTTLE JACKS, FLOOR JACKS AND STANDS	034 - 038
 TORQUE WRENCHES	039 - 042
 WRENCHES AND WRENCH SETS	043 - 052
 INDIVIDUAL HAND SOCKETS, ACCESORIES AND SOCKET SETS	053 - 073
 INDIVIDUAL IMPACT SOCKETS, ACCESORIES AND SOCKET SETS	074 - 082
 HAMMERS	083 - 086
 PLIERS, NIPPERS AND CUTTERS	087 - 096
 SCREWDRIVERS AND BITS	097 - 101
 TORX, HEX KEY AND HEX KEY SETS	102 - 106
 CUTTING WHEEL, GRINDING WHEEL AND ACCESSORIES	107 - 115
 VEHICLES AND BODY REPAIR TOOLS	116 - 133
 MOTORCYCLE REPAIR TOOLS	134 - 137
 CONSTRUCTION MAINTENANCE TOOLS	138 - 145
 FOOT PROTECTION	146 - 149
 EYE PROTECTION	150 - 154
 EAR PROTECTION	155 - 157
 HEAD & FACE PROTECTION	158 - 160
 SPECIAL HAZARD WORK WEAR	161 - 163
 RESPIRATORY PROTECTION	164 - 165



DISPLAY STAND, TOOL CHEST, TOOL BOXES AND ASSORTMENTS



Display Safety Uses

- Ensure tools are distributed properly on the display to ensure stability.
- Display should always be placed on a level surface. The stand has adjustable feet for use on unlevel surfaces.
- Do not load the displays with excessive weight.
- Check that trays and hooks are fixed securely.

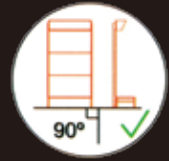

Cabinets, Boxes & Tools Set Safety Uses

- Oil the smooth action runners
- Always keep the drawers and doors of the cabinets locked during movement or transportation
- Do not stack items on the cabinet as they may fall if it moved.
- Do not use the boxes as supports for work surfaces.
- Do not overload the drawer of the cabinets or boxes with excessive weight.
- Do not open more than one loaded drawer at a time
- Do not overload drawers.
- Do not pull a tool cabinet, push.

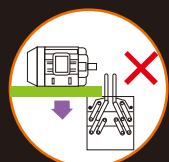
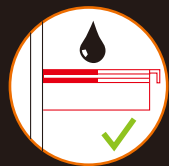

Handling Tools Boxes

- Cautions:
 - Watch your back when lifting heavy containers.
 - Do not stand on a tool box.
 - Mind your hands-sharp or rough objects should not be kept loose.

MK-EQP-010 DISPLAY STAND

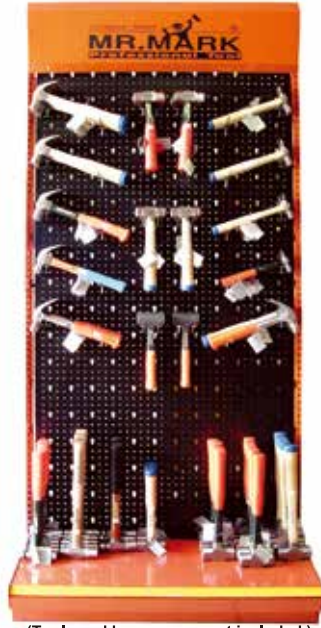
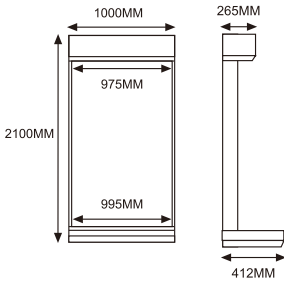

(Tools and hangers are not included.)

- The Mr. Mark display stand can be easily assembly
- The high grade solid sheet steel panel display stand can be remain sturdy without any risk of tilting even for the highest loads
- Can be used to display various type of hand tools with hangers
- Creating impressive presentation of merchandise
- Powdered coating finish to resist scratch
- Ideal for modern showrooms and sales areas

ITEM CODE	DESCRIPTION	QTY/CTN	PRICE
MK-EQP-010	Display Stand	1	1,194.00

MK-EQP-014 DISPLAY PANEL

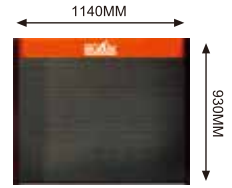

(Tools and hangers are not included.)

☺ Custom-made designs are also available to suit individual requirements.

- Made from high grade solid sheet steel allow for higher load
- Easy mounting on wall by using the two slots located at the back of the panel
- Can be used to display various type of hand tools with hangers
- Powdered coating finish to resist scratch
- Ideal for workshop, work station, school and maintenance room

ITEM CODE	DESCRIPTION	QTY/CTN	PRICE
MK-EQP-014	Display Panel	1	480.00

MK-EQP-015 HEAVY-DUTY WORKBENCH



DIMENSION:
1260mm(W) x 700mm(D) x 850mm(H)

- Compact and solid sheet-steel construction.
- Multi-ply woodwork surface with laminated plastic finish.
- Ideal for operation in compact areas, thanks to reduced dimensions.
- Sturdy and durable.
- Automotive and industrial maintenance.

ITEM CODE	DESCRIPTION	QTY/CTN	PRICE
MK-EQP-015	HEAVY-DUTY WORKBENCH	1	2,467.10

MK-EQP-0306 WORKBENCHES

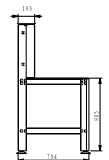
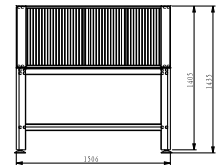

- Both shutter can be open up, biggest visibility and storage
- Circularly corner design of workstation is more beauty and softness for protecting the end user
- Mesh can be hanging tools through hook system mesh
- Tool chest can be setting under the workstation in any side
- Powdered coating finish to resist scratch
- Heavy duty metal for body construction and handle to provide ultimate durability
- Powdered coating finish to resist scratch

ITEM CODE	DESCRIPTION	QTY/CTN	PRICE
MK-EQP-0306	Workbenches	1	3,973.90

ROLLER CABINETS UNIQUENESS



Integrated ergonomic handle within the worktop. Polypropylene worktop.



Optimized storage-compatible with the modular storage system.



Full-extension ball bearing drawer slides open and close easier.



Drawer release mechanism incorporated within the handle, to prevent accidental drawer opening.



Central locking with two reversible keys provide security.



Anti-shock protection on all four corners.



Heavy duty wheels.
-125mm diameter for easy crossing of obstacles.
-Non-protruding wheels for easy manoeuvring around the workshop.
-Two fixed wheels and two castors, one with brake.



(Tools are not included.)

MK-EQP-0300 6 DRAWER ROLLER CABINET

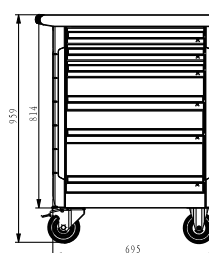
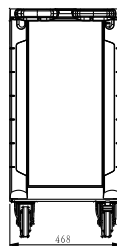

MK-300	WIDTH	DEPTH	HEIGHT	WEIGHT
Overall	766mm	465mm	958mm	54kg
Drawer	WIDTH	DEPTH	HEIGHT	Load
3 Small Drawers	533mm	391mm	58mm	25kg
2 Medium Drawers	533mm	391mm	128mm	35kg
1 Large Drawers	533mm	391mm	195mm	35kg
Wheel				
125mm				

- Full double wall construction features two full layers of heavy duty steel provides strength and durability
- Integrated ergonomic handle within the worktop and Anti-shock plastic worktop
- Drawers on telescopic full-extension ball bearing slides open and close easier as load increases up to 50 IBs
- Side perforated panels to hang tools and accessories
- Centralised security locking
- Anti-topple system preventing the drawer from sliding open accidentally
- Featured with four 125mm castors and one with brake to help secure unit in position
- Anti-shock protection on all four corners with plastic to prevent accidental damage
- Strong plastic worktop for knock on and storage
- Powdered coating finish to resist scratch

ITEM CODE	DESCRIPTION	QTY/CTN	PRICE
MK-EQP-0300	6 Drawer Roller Cabinet	1	3,461.70

MK-EQP-0301 4 DRAWER CHEST AND ROLLER CABINET

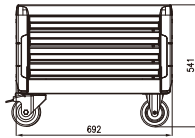
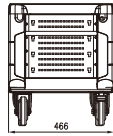

MK-301	WIDTH	DEPTH	HEIGHT	WEIGHT
Overall	690mm	465mm	400mm	43kg
Overall With Casters	690mm	465mm	545mm	
Drawer	WIDTH	DEPTH	HEIGHT	Load
4 Small Drawers	533mm	391mm	58mm	25kg
Wheel	125mm			

- ABS worktop for knock on and storage
- Four drawers on telescopic full-extension ball bearing slides open and close easier as load increases
- Each drawer fitted with a side catch to prevent unexpected opening, when being transported around the work shop
- Anti-shock protection on all four corners with plastic to prevent accidental damage
- Centralised security locking and drawer catch system
- Featured with four 125mm castors and one with brake to help secure unit in position
- Locking brake to help secure unit in position
- Folding pulling handle
- Powdered coating finish to resist scratch

ITEM CODE	DESCRIPTION	QTY/CTN	PRICE
MK-EQP-0301	4 Drawer Chest And Roller Cabinet	1	2,359.50

MK-EQP-018 7-DRAWERS ROLLER CABINET WITH MIS SYSTEM

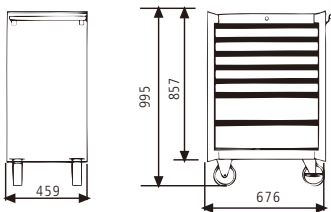

MK-018	WIDTH	DEPTH	HEIGHT
Overall	676mm	459mm	857mm
Overall With Casters	676mm	459mm	995mm
5 Drawers	569mm	398mm	73mm
2 Drawers	569mm	398mm	153mm

- Featured with Internal Locking System (MIS) for extra security
- Anti-vibration rubber mat on top
- Powdered coating finish to resist scratch
- Suitable for automotive workshop, tire workshop, factory maintenance and other

ITEM CODE	DESCRIPTION	QTY/CTN	PRICE
MK-EQP-018	7 Drawers Roller Cabinet With MIS System	1	3263.00

MK-EQP-0302 6 DRAWER MOBILE WORKBENCH

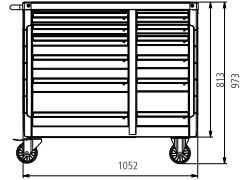
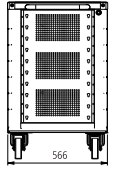

MK-302	WIDTH	DEPTH	HEIGHT	WEIGHT
Overall	1130mm	570mm	1000mm	87kg
Drawer	WIDTH	DEPTH	HEIGHT	Load
3 Small Drawers	533mm	391mm	58mm	25kg
2 Medium Drawers	533mm	391mm	128mm	35kg
1 Large Drawers	533mm	391mm	195mm	35kg
Wheel	160mm			

- Ultra heavy duty worktop of galvanized steel on a 15mm thick wooden base, for impact and hear resistant
- All drawers on telescopic full-extension ball bearing slides open and close easier as load increases
- Centralised security locking and catch system to prevent unexpected opening, when being transported around the work shop
- Small drawer workload up to 25kg, intermediate and large drawer and to 35kg, high strength slides and compatible with modular storage system
- Featured with one lockable bin for storing bulky objects
- Compatible with the range of side mounted accessories
- Featured with very large diameter casters (160mm) allowing the bench to be easily ride over pipes and door rails
- One open bin for storing bulky objects (with shelf)
- Locking brake to help secure unit in position
- Anti-shock protection on all four corners with plastic to prevent accidental damage
- Powdered coating finish to resist scratch

ITEM CODE	DESCRIPTION	QTY/CTN	PRICE
MK-EQP-0302	6 Drawer Mobile Workbench	1	4,843.20

MK-EQP-019 5-DRAWERS ROLLER CABINET WITH MIS SYSTEM

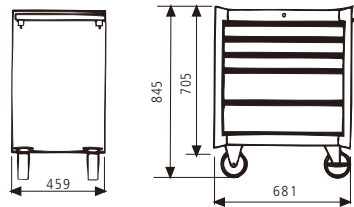

MK-019	WIDTH	DEPTH	HEIGHT
Overall	676mm	459mm	702mm
Overall w/2" Casters	676mm	459mm	840mm
3 Drawers	569mm	398mm	75mm
2 Drawers	569mm	398mm	154mm

- Featured with Internal Locking System (MIS) for extra security
- Anti-vibration rubber mat on top
- Powdered coating finish to resist scratch
- Suitable for automotive workshop, tire workshop, factory maintenance and other

ITEM CODE	DESCRIPTION	QTY/CTN	PRICE
MK-EQP-019	5 Drawers Roller Cabinet With MIS System	1	2816.10

**MK-EQP-0303
3 DRAWER DETACHABLE
TOOL CART**

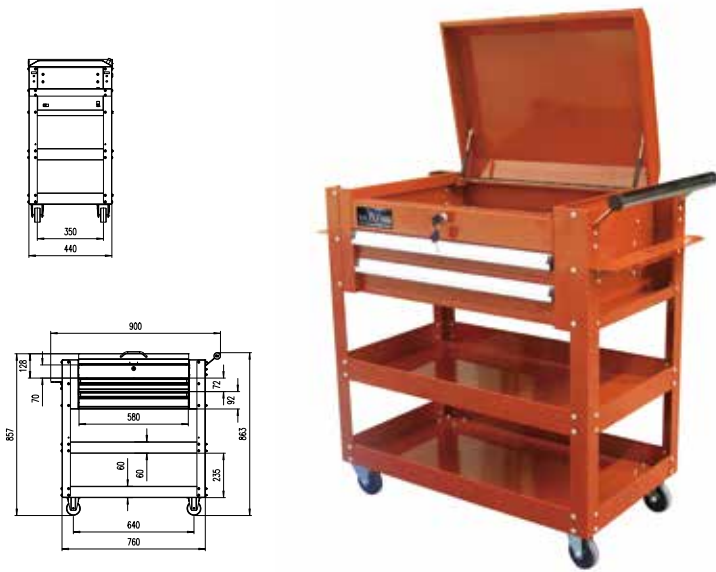

MK-303	WIDTH	DEPTH	HEIGHT
Overall	760mm	440mm	760mm
Overall With Casters	900mm	440mm	895mm
Casters	4 inch (2 universal, 2 directional with brake)		

- Cabinet steel thickness (Body: 1.5mm ; Drawer: 0.8mm, Cover 1.0mm)
- Featured with Internal Locking System (MIS) for extra security
- Side handle design for holding tools and etc
- Powdered coating finish to resist scratch
- Suitable for automotive workshop, tire workshop, factory maintenance and other

ITEM CODE	DESCRIPTION	QTY/CTN	PRICE
MK-EQP-0303	3 Drawer Detachable Tool Cart	1	1,150.40

**MK-EQP-0304
3 DRAWER CHEST
AND ROLLER CABINETS
(ORANGE)**

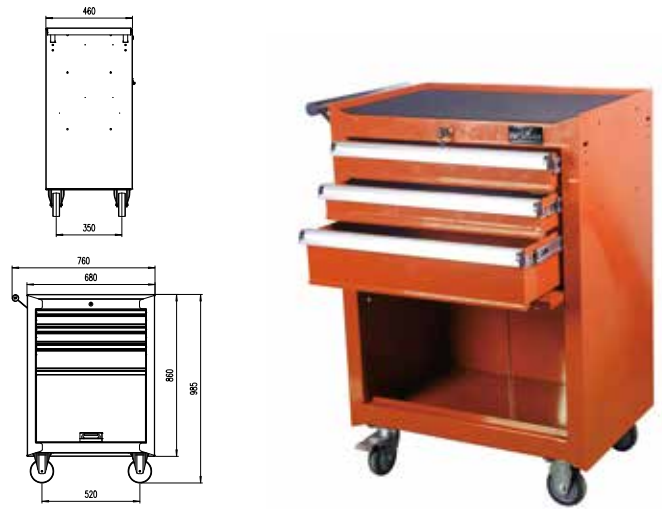

MK-304	WIDTH	DEPTH	HEIGHT
Overall	680mm	460mm	860mm
Overall With Casters	760mm	460mm	1000mm
Casters	5 inch (2 universal, 2 directional with brake)		
Drawers (H)	3 (92mm, x 2, 142mm x1)		

- Cabinet steel thickness (Body: 1.2mm ; Drawer: 1.0mm)
- Featured with Internal Locking System (MIS) for extra security
- Anti-vibration rubber mat on top
- Powdered coating finish to resist scratch
- Suitable for automotive workshop, tire workshop, factory maintenance and other

ITEM CODE	DESCRIPTION	QTY/CTN	PRICE
MK-EQP-0304	3 Drawer Chest And Roller Cabinets	1	1,618.10

**MK-EQP-16A-BLK
CHEST AND ROLLER
CABINET**



MK-16A	WIDTH	DEPTH	HEIGHT
Overall	559mm	307mm	705mm
Overall With Casters	559mm	307mm	785mm
Package	625mm	365mm	775mm
2 Drawers	391mm	278mm	56.5mm

- Cabinet steel thickness (Body: 1.2mm ; Drawer: 1.0mm)
- Featured with Internal Locking System (MIS) for extra security
- Featured with 2.5" swivel caster for easy moving
- Powdered coating finish to resist scratch
- Suitable for bicycle and motorcycle repair works

ITEM CODE	DESCRIPTION	QTY/CTN	PRICE
MK-EQP-16A-BLK	Chest And Roller Cabinet	1	827.70

**MK-EQP-0308
3 LEVEL TOOL CART TROLLEY**

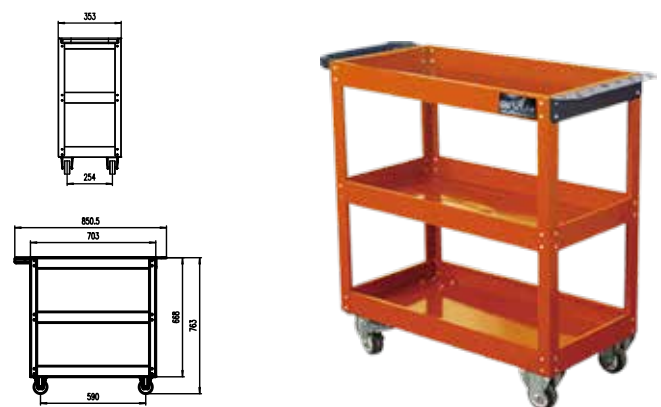

MK-308	WIDTH	DEPTH	HEIGHT
Overall	705mm	353mm	668mm
Overall With Wheels & Handle	850mm	353mm	763mm

- Steel thickness (Tray: 0.6mm ; Column: 0.8mm)
- Side handle design for holding tools such as screwdriver and hand tools
- Heavy duty ball bearing casters for smooth moving and durable
- Powdered coating finish to resist scratch
- Suitable for automotive workshop, tire workshop, factory maintenance and other

ITEM CODE	DESCRIPTION	QTY/CTN	PRICE
MK-EQP-0308	3 Level Tool Cart Trolley	1	345.00

MK-EQP-0305 CANTILEVEL TOOL BOX

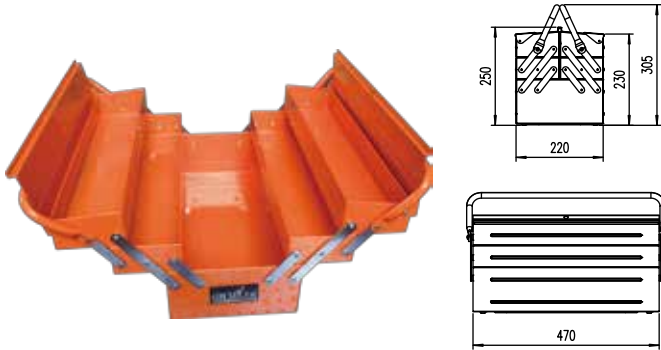

MK-305	WIDTH	DEPTH	HEIGHT
Overall	470mm	220mm	250mm
Overall With Handle	470mm	220mm	305mm

- Steel thickness (Top cover: 0.8mm ; Other: 0.6mm)
- Larger compartment space and allowed tool box open in full extension for tools picking easily
- Supplied with padlock eye
- Powder coating finish to resist scratch and solvent marking
- Heavy duty metal for body construction and handle to provide ultimate durability

ITEM CODE	DESCRIPTION	QTY/CTN	PRICE
MK-EQP-0305	220 X 250 Cantilevel Tool Box	1	157.30

MK-EQP-0309 CANTILEVEL TOOL BOX

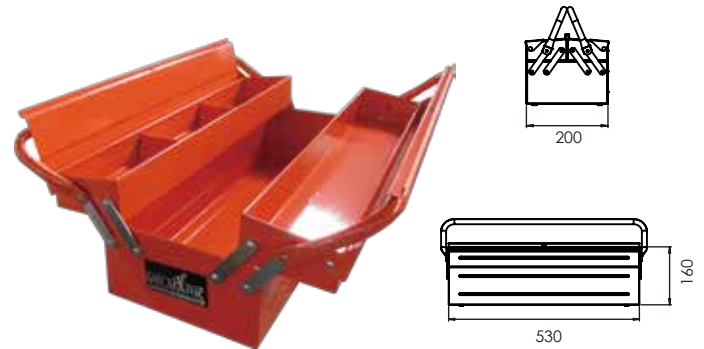

MK-309	WIDTH	DEPTH	HEIGHT
Overall	530mm	200mm	160mm
Overall With Handle	560mm	200mm	230mm

- Steel thickness (Top cover: 0.8mm ; Other: 0.6mm)
- Supplied with padlock eye
- Powder coating finish to resist scratch and solvent marking
- Heavy duty metal for body construction and handle to provide ultimate durability

ITEM CODE	DESCRIPTION	QTY/CTN	PRICE
MK-EQP-0309	Cantilevel Tool Box	2	126.50

MK-EQP-M380 TOOLS BOX



DIMENSION:
380mm(L) X 190mm(W) X 142mm(H)

- Build in organiser and tray are removable and can be carried outside the tools box.

ITEM CODE	DESCRIPTION	QTY/CTN	PRICE
MK-EQP-M380	Tools Box		23.00

MK-EQP-025 PVC SUPER BOX II*



DIMENSION:
445mm(L) X 241mm(W) X 222mm(H)

- Organiser on top and accessible without opening the box
- Feature with padlock eye
- Build in organiser and tray are removable and can be carried outside the tools box
- Ideal for handyman, carpenter, fisherman, mechanic and etc.

ITEM CODE	DESCRIPTION	QTY/CTN	PRICE
MK-EQP-025	PVC Super Box II	6	69.90

MK-EQP-026 PVC H/DUTY SUPER BOX (FREE TYPE)



DIMENSION:
445mm(L) X 241mm(W) X 220mm(H)

- Organiser on top accessible without opening the box and removable
- Feature with padlock eye
- Build in organiser and tray are removable and can be carried outside the tools box
- Ideal for handyman, carpenter, fisherman, mechanic, household and etc

ITEM CODE	DESCRIPTION	QTY/CTN	PRICE
MK-EQP-026	PVC H/Duty Super Box (Free Type)	6	64.20

MK-EQP-027 PVC DELUXE BOX II*



DIMENSION:
445mm(L) X 241mm(W) X 268mm(H)

- Organiser on top accessible without opening the box
- Feature with padlock eye
- Build in organiser and tray are removable and can be carried outside the tools box
- Ideal for handyman, carpenter, fisherman, mechanic, household and etc

ITEM CODE	DESCRIPTION	QTY/CTN	PRICE
MK-EQP-027	PVC Deluxe Box II	6	81.00

MK-EQP-028 PVC DELUXE BOX (FREE TYPE)



DIMENSION:
445mm(L) X 241mm(W) X 265mm(H)

- Organiser on top and bottom accessible without opening the box and removable
- Feature with padlock eye
- Build in organiser and tray are removable and can be carried outside the tools box
- Ideal for handyman, carpenter, fisherman, mechanic and multi-purpose usage

ITEM CODE	DESCRIPTION	QTY/CTN	PRICE
MK-EQP-028	PVC Deluxe Box (Free Type)	6	76.50

MK-EQP-030 PVC AUTO BOX



DIMENSION:
535mm(L) X 250mm(W) X 238mm(H)

- Organiser on top accessible without opening the box and removable
- Feature with padlock eye and larger compartment
- Build in organiser and tray are removable and can be carried outside the tools box

ITEM CODE	DESCRIPTION	QTY/CTN	PRICE
MK-EQP-030	PVC Auto Box	6	104.40

MK-EQP-035 TOOLS ORGANIZER WALL MOUNTING SCREWS*



(Tools are not included.)

ITEM CODE	DESCRIPTION	QTY/CTN	PRICE
MK-EQP-035	Tools Organizer Wall Mounting Screws	40	46.20

MK-EQP-036 1/2" DR.SOCKET ORGANIZER WALL MOUNTING SCREWS *



(Sockets are not included.)

ITEM CODE	DESCRIPTION	QTY/CTN	PRICE
MK-EQP-036	1/2" Dr.Socket Organizer Wall Mounting Screws	40	42.70

MK-EQP-032 STRACKABLE CONTAINER



- Highly durable
- Smooth surface and rounded corners make for swift, hassle free cleaning
- Ideal for transporting and storing wide range of goods

Item Code:	MK-EQP-032-K1218
Description	Stackable container - S
Dimension(LxBxH)mm	180x123x85
Colour	Orange
Qty per carton	72 pieces

Item Code:	MK-EQP-032-K1525
Description	Stackable container - M
Dimension(LxBxH)mm	260x158x125
Colour	Orange
Qty per carton	36 pieces
Price	15.50

Item Code:	MK-EQP-032-K2035
Description	Stackable container - L
Dimension(LxBxH)mm	351x210x148
Colour	Orange
Qty per carton	18 pieces
Price	22.30

Item Code:	MK-EQP-032-K28
Description	Stackable container - XL
Dimension(LxBxH)mm	475x296x178
Colour	Orange
Qty per carton	12 pieces
Price	45.20

**MK-EQP-037
WRENCH ORGANIZER WALL
MOUNTING SCREWS***



(Tools are not included.)

ITEM CODE	DESCRIPTION	QTY/CTN	PRICE
MK-EQP-037	Wrench Organizer Wall Mounting Screws	40	42.70

**MK-EQP-042 POLYESTER TOOL BAG
WITH 7 ATTACHMENT (HEAVY
DUTY)***



Size: 17.5 X 6 X 13"

- Rugged, Water resistant 600 denier fabric
- 7 removable attachments to hold your tools
- Two plastic buckles to close it tightly
- Handle & shoulder strap to keep your hands free



(Tools are not included)

ITEM CODE	DESCRIPTION	QTY/CTN	PRICE
MK-EQP-042	Polyester Tool Bag With 7 Attachment (Heavy Duty)	1	280.90

**MK-EQP-044 POLYESTER TOOL BAG
FOR TECHNICIANS***



Size: 22 X 18 X 22"

- Rugged, Water resistant 600 denier fabric
- 13 Interior & exterior pockets to hold tools
- Lower zip section to hold your valuables



(Tools are not included)

ITEM CODE	DESCRIPTION	QTY/CTN	PRICE
MK-EQP-044	Polyester Tool Bag For Technicians	4	149.00

**MK-EQP-038
DIY HOOK***



ITEM CODE	DESCRIPTION	QTY/CTN	PRICE
MK-EQP-038-04	4" Diy Hook (Chrome)		4.30
MK-EQP-038-08	8" Diy Hook (Chrome)		5.20

**MK-EQP-043 POLYESTER TOOL BAG
WITH INNER & OUTER POCKETS***



Size: 23 X 18 X 15"



(Tools are not included)

- 2 side sections close with 27 pockets
- Centre pocket ideal for cordless tools

ITEM CODE	DESCRIPTION	QTY/CTN	PRICE
MK-EQP-043	Polyester Tool Bag With Inner & Outer Pockets	20	165.40

**MK-EQP-040 TOOL ORGANIZER-
SOFT SIDE***

SIZE: 13 x 4.5 x 16"



- Small, lightweight and strong
- Zippered for secure transport
- Padded handle features reinforced stitching for extra strength
- Extra-wide opening provides easy access to all tools
- 600D Polyester is durable and virtually maintenance free
- Industrial-grade metal clasps provide added strength for heavy loads
- Uniquely configured pockets are reinforced on the bottom to resist wear and punctures

ITEM CODE	DESCRIPTION	QTY/CTN	PRICE
MK-EQP-040	Tool Organizer-Soft Side	10	62.70

MK-EQP-047 POLYESTER CARRY BAG*



SIZE: 12 x 4.5 x 16.5"

- Polyester carry bag with shoulder strap.
- Material: Polyester with synthetic leather.

ITEM CODE	DESCRIPTION	QTY/CTN	PRICE
MK-EQP-047	Polyester Carry Bag	10	112.30

TOOLS KIT



Cabinets, Boxes & Tools Set Safety Uses

- Oil the smooth action runners
- Always keep the drawers and doors of the cabinets locked during movement or transportation
- Do not stack items on the cabinet as they may fall if it moved.
- Do not use the boxes as supports for work surfaces.
- Do not overload the drawer of the cabinets or boxes with excessive weight.
- Do not open more than one loaded drawer at a time
- Do not overload drawers.
- Do not pull a tool cabinet, push.

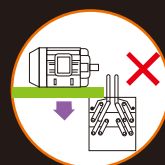
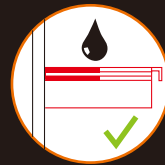

Handling Tools Boxes

- Cautions:
 - Watch your back when lifting heavy containers.
 - Do not stand on a tool box.
 - Mind your hands-sharp or rough objects should not be kept loose.

MK-LITE-4813

13PCS LITE SERIES TOOLS SET



Suitable for:



Home Improver

DIY quality tooling. Designed for home use and light industrial applications.



Maintenance

Products designed for general maintenance of machines, workshops, garage and some household applications.

- A basic tools for household, home hobby and light industry maintenance use
- Supplied with ABS carrying case with proper tools management
- For wide range of application such as: hanging poster, picture or wall mirror fitting pipe, basin, water hose or toilet, assembly cabinet or furniture, replace lighting and bulbs, packing goods, minor fitting and repair works

CONTENTS (13pcs)

QTY	DESCRIPTION	SIZE	FINISH
1PC	Hex Key Set	Size: 1.5,2,2.5, 3,4,5.5,5,6mm	Carbon Steel with Nickel Plated Finish
2PCS	Precision Screwdriver	PH0, SL 2.0	Carbon Steel with Nickel Plated Finish
1PC	Scissors	5-1/2"	
1PC	Adjustable Wrench	8"	Carbon Steel with Chrome Plated Finish
1PC	Machinist's Hammer	300G	Carbon Steel with Black Finished
1PC	Utility Knife	18mm	Carbon Steel
1PC	Measuring Tape	5M/15FT	
1PC	Combination Pliers	6"	Carbon Steel With Fully Polish Finish
4PCS	Screwdriver	SL5*75mm SL6*100mm PH1*75mm PH2*100mm	Carbon Steel with Chrome Plated Finish
1PC	Carrying Case		

MK-LITE-4827

27PCS LITE SERIES TOOLS SET



Suitable for:



Home Improver

DIY quality tooling. Designed for home use and light industrial applications.



Maintenance

Products designed for general maintenance of machines, workshops, garage and some household applications.

- A basic tools for household, home hobby and light industry maintenance use
- Supplied with ABS carrying case with proper tools management
- For wide range of application such as: hanging poster, picture or wall mirror fitting pipe, basin, water hose or toilet, assembly cabinet or furniture, replace lighting and bulbs, packing goods, minor fitting and repair works

CONTENTS (27pcs)

QTY	DESCRIPTION	SIZE
1PCS	Adjustable Wrench	10"
1PCS	Water Pump Pliers	9-1/2"
1PCS	Combination Pliers	7"
1PCS	Diagonal Pliers	7"
1PCS	Long Nose Pliers	7"
1PCS	Scissors	7"
1PCS	Machinist Hammer	300g
3PCS	Screwdriver	PH1*75mm, PH2*100mm SL4*75mm
4PCS	Precision Screwdriver	SL2.0*PH0, SL3.0*PH0, SL4.0*PH1, Quick Chuck
1PCS	Measuring Tape	3m/10FT
1PCS	Utility Knife	
1PCS	Hack Saw	6"
10PCS	Hex Key	1.5,2,2.5,3,4,5,5.5,6,8,10mm
1PCS	Carrying case	

ITEM CODE	DESCRIPTION	QTY/CTN	PRICE
MK-LITE-4813	13 Pcs Lite Series Tools Set	4	168.80

ITEM CODE	DESCRIPTION	QTY/CTN	PRICE
MK-LITE-4827	27 Pcs Lite Series Tools Set	4	437.50

MK-LITE-4851

51PCS LITE SERIES TOOLS SET (ALU. CASE)



Suitable for:



Home Improver

DIY quality tooling. Designed for home use and light industrial applications.



Maintenance

Products designed for general maintenance of machines, workshops, garage and some household applications.



Industrial

Designed for regular use in industrial applications. Manufactured to stringent quality levels and international standards.

- A professional tools kit for machinery and industry maintenance uses
- Supplied with aluminium carrying case with proper tools management
- For wide range of application such as : minor machinery or engine maintenance repair work, replace lighting and bulbs, repair electrical, basic carpentry works such as fitting cabinet, working bench, office furniture, assembly computer and network, packing goods and etc

MK-LITE-4855

55PCS LITE SERIES TOOLS SET



Suitable for:



Home Improver

DIY quality tooling. Designed for home use and light industrial applications.



Maintenance

Products designed for general maintenance of machines, workshops, garage and some household applications.



Renovator

Designed for Renovator use and light industrial applications.

- A professional tools kits for household, home hobby and contractor
- Supplied with ABS carrying case with proper tools management
- Can be used for tightening and loosening different size and types of screws (Philip, slotted, Hex socket, Torx, Star)
- For wide range of application such as: hanging picture or wall mirror, fitting pipe, water hose, basin or toilet, assembly cabinet or furniture, assembly sound systems, repair electrical and kitchenware, replace lighting and bulbs, minor renovation or repair works

CONTENTS (51pcs)

QTY	DESCRIPTION	SIZE	FINISH
6PC	Combination Wrench	10,12,13,14,17,19MM	Carbon Steel With Chrome Plated Finish
6PC	Screwdriver	SL6*38MM, SL5*75MM, SL6*100MM, PH2*38MM, PH1*75MM, PH2*100MM	Chrome Vanadium With Two Tone Handle
11PC	Hex Key	1.27, 1.5, 2.2, 2.5, 3, 3.5, 4, 4.5, 5, 5.5, 6mm	Carbon Steel With Black Finished
1PC	Measuring Tape	3M/10FT	ABS with two colour
1PC	Adjustable Wrench	8"	Carbon steel with chrome plated finishd
1PC	¼" Ratchet Handle	72 teeth	Chrome Vanadium with Mirror Plated Finish
9PC	¼" Dr. Socket	5, 6, 7, 8, 9, 10, 11, 12, 13mm	50BV30, Chrome Plated With Mirror Plated Finish
1PC	Mechanical Hammer	300G	Carbon Steel Black With Wood Handle
1PC	Combination Pliers	6"	Carbon Steel With Fully Polished Finish With Two Tone Handle
1PC	Long Nose Pliers	6"	Carbon Steel With Fully Polished Finish With Two Tone Handle
1PC	Water Pump Pliers	10"	Carbon Steel With Fully Polished Finish With Two Tone Handle
10PC	25mm Bit	(-)3,4,5,6, (+)1,2,3, (t)15,20,30	Chrome Vanadium 6150 With Sanding Blaster Finish
1PC	Magnetic Holder	60mm	Carbon Steel, Zinc Alloy
1PC	¼" Screwdriver Handle		
1PC	Aluminium Case		

CONTENTS (55pcs)

QTY	DESCRIPTION	SIZE	FINISH
1PC	Utility Knife	18MM	Carbon Steel with Two Tone Handle
6PC	Knife Blade	18MM	Carbon Steel
1PC	Torpedo Level	9"	
1PC	Adjustable Wrench	6"	Carbon Steel with Chrome Plated
6PC	Screwdriver	SL3*75mm-SL6*100mm SL6*150mm-PH0*75mm PH2*100mm-PH2*150mm	Carbon Steel with Two Tone Handle
1PC	¼" Screwdriver Handle		Carbon Steel with Chrome Plated Finish and Two Tone Handle Plastic with Shell
1PC	Measuring Tape	3M/10FT	
1PC	Water Pump Pliers	10"	Carbon Steel Chrome Plated with Two Tone Handle
1PC	Combination Pliers	6"	Carbon Steel with Fully Polished Finish With Two Tone Handle
1PC	Long Nose Pliers	6"	Carbon Steel with Fully Polished Finish With Two Tone Handle
1PC	Diagonal Pliers	6"	Carbon Steel with Fully Polished Finish With Two Tone Handle
1PC	Claw Hammer	8 OZ	Carbon Steel with Tubular Handle
20PC	25mm Bit	(-)3,4,5,6,7, (+)1,2,3, (T)10,15,20,25,30 (H)3,4,5,6, (S)1,2,3	Chrome Vanadium 6150 with Sanding Blaster Finish
9PC	Hex Key	1.5, 2.2, 2.5, 3, 4, 5, 6, 8, 10mm	Carbon Steel with Nickel Plated Finish
1PC	Hex Key Holder		Plastic
2PC	Bit Holder		
1PC	Carrying Case		Plastic

ITEM CODE	DESCRIPTION	QTY/CTN	PRICE
MK-LITE-4851	51 Pcs lite Series Tools Set	3	421.50

ITEM CODE	DESCRIPTION	QTY/CTN	PRICE
MK-LITE-4855	55 Pcs Lite Series Tools Set	4	278.00

MK-SET-392

130 PCS TOOLS KIT SET (ALU. CASE)



Size: 470mm x 167mm x 382mm

- Durable solid aluminium carrying case
- Supplied with 130pcs complete hand tools kit
- Perfect for general maintenance work



Contain Precision Screwdriver Kit



Contain Multi Type Screwdriver Kits

Material: All CR-V, Mirror Finished, W/Knurlled, W/Laser Logo & Size, Bit S2

CONTENTS

Board 1 (4 Pcs)

- 1Pc - Hack Saw 12"
- 1Pc - Level 3 Valves
- 1Pc - Adjustable Wrench 250mm
- 1Pc - File

Board 2 (8 Pcs)

- 1Pc - Water Pump Plier 9-1/2"
- 1Pc - Diagonal Plier 6"
- 1Pc - Long Nose Plier 6"
- 1Pc - Stainless Steel Heavy Duty Scissors 7"
- 1Pc - Combination Pliers 7"
- 1Pc - Utility Knife W/3 Pcs Blades
- 1Pc - Machinist Hammer 300 G
- 1Pc - Carpenters Pincers 10"

Board 3 (60 Pcs)

- 1Pc - Bit Holder Screwdriver
- 4Pcs - Screwdrivers PH1x75mm, PH2x100mm, SL5.5x75mm, SL6.5x100mm
- 4Pcs - VDE Screwdrivers PH1x75mm, PH2 x100mm, SL4x100mm, SL5.5x125mm
- 1Pc - Tester 120-250V
- 5Pcs - Punches & Chisels
- 4Pcs - 6 In 1 Changeable Precisions Screwdriver
- 41Pcs - Bits Set W/Box
- 1Pc - Bit Holder W/Quick Release
- 1Pc - Bit Adaptor
- 39Pcs - Bits

Board 4 (58 Pcs)

- 1/4" Dr.Sockets • 13Pcs - 4,4.5,5,5.5,6,7,8,9,10,11,12,13,14mm
- 2Pcs - Extension Bars 50mm, 100mm
- 1Pc - Lever Type Ratchet Handle W/48 Teeth Gear
- 1Pc - Sliding T Bar
- 1Pc - Universal Joint
- 1Pc - Coupler 1/4"Dr. x 1/4"Hex
- 1/2" Dr.Sockets • 13Pcs - 10, 12, 13, 14, 16, 17, 18, 19, 20, 22, 24, 27, 30, 32mm
- 2Pcs - Spark Plug Sockets 16Mm, 21mm
- 2Pcs - Extension Bars 125mm, 250mm
- 1Pc - Lever Type Ratchet Handle W/48 Teeth Gear
- 1Pc - Universal Joint
- 1Pc - Sliding T Head 3/8"(F)x1/2"(M)
- 1Pc - Calliper
- 9Pc - Combination Wrenche 8,10,11,12,13,14,17,19, 22MM
- 9Pc - Hex Key 1.5,2,2.5,3,4,5,6,8,10MM
- 1Pc - Caliper
- 1Pc - Aluminium Case

MK-SET-393

62 PCS 1/2" DR.SOCKET & TOOL SET



Size: 420mm x 220mm x 200mm



Thick & patented design box



Textures



3 pin riverter enhance quality



Tools Contain

- Tools box made from high grade solid sheet steel with attractive stamping design for extra durability
- Supplied with 62pcs hand tools kit
- With removable tray and side fold down handle
- Featured with pad lock eye
- Powdered coating finish to resist scratch

Material: All CR-V, Mirror Finished, W/Knurlled, W/Laser Logo & Size, Bit S2

CONTENTS

Tray 1 (21Pcs)

- 10-1/2" Dr. Socket 8, 10,12,13,14,15,16,17,18,19mm
- 5-Deepsockets 8, 10, 12, 13, 14mm
- 1-Universal Joint
- 2-Extension Bars 75Mm,150mm
- 1-Coupler 1/2"(F) X 1/4"(H)
- 1-Lever Type Ratchet Handle W/48 Teeth Gear
- 1-Flexible Handle

Tray 2 (34Pcs)

- 1-Spin Ratchet 72 Teeth
- 1-Bit Adaptor 1/4" X 25mm
- 19-25mm Bits (+) 1, 2, 3 (-) 4.5, 6.5, 8 (H) 3, 4, 5, 6, 7, 8 (T) 10, 15, 20, 25, 27, 30, 40 W/Tamper Proof
- 9-Combination Wrenche 8,10,12,13,14,17,18,19,22mm
- 4-Allen Key 4, 5, 6, 8mm

Tray 3 (7Pcs)

- 1-Locking Plier
- 1-Long Nose Plier 160mm
- 1-Diagonal Plier 160mm
- 1-Combination Plier 180mm
- 1-Bit Holder Driver Handle
- 2-Screwdrivers PH22x150mm, SL6.5x100mm
- 1-Metal Cantilevel Box

ITEM CODE	DESCRIPTION	QTY/CTN	PRICE
MK-SET-392	130 Pcs Tools Kit Set With Alum Tools Case	1	2,122.80

ITEM CODE	DESCRIPTION	QTY/CTN	PRICE
MK-SET-393	62 Pcs 1/2" Dr.Socket & Tool Set	1	1,153.40

MK-EQP-388A

239 PCS 7-DRAWER TROLLEY TOOLS SET (5 DRAWER WITH TOOLS)

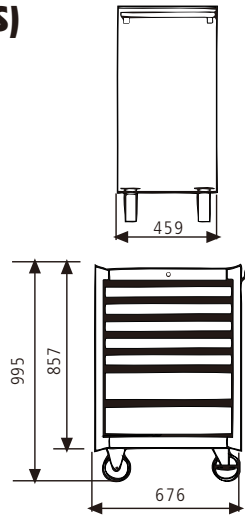

- Cabinet steel thickness (Body: 1.0mm ; Drawer: 0.8mm)
- Featured with Internal Locking System (MIS) for extra security
- Supplied with 239pcs hand tools kit
- Anti-vibration rubber mat on top
- Powdered coating finish to resist scratch
- Suitable for automotive workshop, tire workshop, factory maintenance and other

CONTENTS

DRAWER 1 (32PCS):

- 11Pc - MK-SET-30006: 75" OFFSET DOUBLE RING 6x7, 8x10, 10x12, 12x14, 14x15, 14x17, 17x19, 19x22, 22x24, 24x27, 30x32mm
- 16Pc - MK-SET-30004: COMBINATION WRENCH 6,7,8,9,10,11,12,13,14,15,16,17,18,19,20, 21mm
- 5Pc - MK-SET-30010: COMBINATION WRENCH 22,24,27,30,32mm

DRAWER 2 (20PCS):

- 6Pc - MK-SET-30008: LOCKING PLIERS 10" , COMBINATION PLIERS 7" , DIAGONAL PLIERS 6" LONG NOSE PLIERS 8" , WATER PUMP PLIERS 10" , ADJUSTABLE WRENCH 10"
- 4Pc - MK-SET-30009: 7" SNAP RING PLIERS SS,SB,HS,HB
- 10Pc - MK-SET-30011: CAPE CHISEL 7MM, TAPE CHISEL 3*120MM, 4*120MM, 5*120MM COLD CHISEL 10,24MM, PIN POUCH 2*115MM, 3*125MM, 4*150MM MACHINIST HAMMER 500G

DRAWER 3 (54PCS):

- 27Pc - MK-SET-30002: 1/2" DR. SOCKET 8,10,11,12,13,14,15,16,17,18,19,20,21,22,23,24,27,30, 32mm RATCHET HANDLE, FLEXIBLE HANDLE, EXTENSION BAR 75,125,250mm UNIVERSAL JOINT, SPARK PLUG 16,21mm
- 12Pc - MK-SET-30007: 1/2" DR. DEEP SOCKET 8,10,11,12,13,14,15,17,19,20,22,24mm
- 15Pc - MK-SET-30014: 1/2" IMPACT SOCKET 10,12,13,14,17,19,21,22,24,27mm, EXTENSION BAR 250mm, UNIVERSAL JOINT, DEEP SOCKET (COLOUR) 17,19,21mm

DRAWER 4 (42PCS):

- 12Pc - MK-SET-30012: SCREWDRIVER PH0*75mm, SL3*75mm, PH0*100mm, SL3*100mm, PH1*75mm, SL5*75mm, PH2*38mm, SL6*38mm, PH2*100mm, SL6*100MM, PH2*200MM, SL6*200mm
- 24Pc - MK-SET-30013: 1/2" BIT DR. SOCKET (T)30,40,45,47,50,55,60,70 (H)5,6,7,8,10,12,14,17 (E)10,12,14,16,18,20,22,24
- 6Pc - MK-SET-30005: DOUBLE END SWIVED HEAD WRENCH 10x11, 10x12, 12x13, 12x14, 14x15, 14x17mm

DRAWER 5 (90PCS):

- 17Pc - MK-SET-30015: FLARE NUT WRENCH 8x10, 12x13, 10x12, 12x14, 14x17, 17x19mm DOUBLE RING END WRENCH 6x7, 8x9, 10x11, 12x13, 14x15, 16x17, 18x19, 20x22, 21x23, 24x27, 30x32mm
- 51Pc - MK-SET-30003: 1/4" DR. SOCKET 4,4.5,5,5.5,6,7,8,9,10,11,12,13mm, DEEP SOCKET 8,9,10, 11,12,13mm, EXTENSION BAR 2",4", RATCHET HANDLE, SNAKE BAR, UNIVERSAL JOINT, SLIDING T BAR, SPINNER HANDLE, BIT SOCKET (+)1,2, (-)4,5,5,7, PZ1, PZ2, (T)8,10,15,20,25,30, (H)3,4,5,6 BALL POINT HEX KEY 1.5,2,2.5,3,4,5,6,8,10mm
- 22Pc - MK-SET-30001: 3/8" DR. SOCKET 7,8,9,10,11,12,13,14,15,17,18,19,22MM DEEP SOCKET 10,12,13,14MM, FLEXIBLE HANDLE, RATCHET HANDLE, UNIVERSAL JOINT, EXTENSION BAR 75,150MM
- 1Pc - 7-DRAWER ROLLER CABINET

Drawer 1

MK-SET-30006



MK-1103

MK-SET-30004



MK-1161

MK-SET-30010



MK-1161

Drawer 2

MK-SET-30008



MK-1534

MK-1526

MK-1504

MK-1508

MK-1501

MK-1506

MK-SET-30009



MK-1515

MK-1516

MK-1517

MK-1518

MK-SET-30011



MK-10144

MK-10146

MK-2017

MK-10145

MK-10147

Drawer 3

MK-SET-30002



MK-4120NQ

MK-4400

MK-4700

MK-4800

MK-4200

MK-4305

MK-SET-30007



MK-4300

MK-4302

MK-SET-30014



MK-84800

MK-84200

MK-84304C

MK-84400

Drawer 4

MK-SET-30012



MK-600

MK-800

MK-SET-30013



MK-4024

MK-4026

MK-4410

MK-SET-30005



MK-1181

Drawer 5

MK-SET-30015



MK-1105M

MK-1151M

MK-SET-30003



MK-2028

MK-2200

MK-2770

MK-2027

MK-2022-PH1,2

MK-2023-PZ1,2

MK-SET-30001



MK-4700

MK-31200

MK-3200

MK-3800

MK-3300

ITEM CODE	DESCRIPTION	QTY/CTN	PRICE
MK-EQP-388A	239 Pcs 7-Drawer Trolley Tools Set	1	6,761.00

MK-EQP-390

151 PCS 5-DRAWER TROLLEY TOOLS SET (4 DRAWER WITH TOOLS)

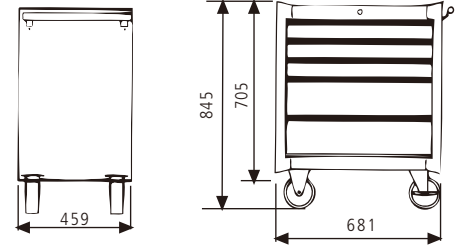

- Cabinet steel thickness (Body: 1.0mm ; Drawer: 0.8mm)
- Featured with Internal Locking System (MIS) for extra security
- Supplied with 150pcs hand tools kit
- Anti-vibration rubber mat on top
- Powdered coating finish to resist scratch
- Suitable for automotive workshop, tire workshop, factory maintenance and other

CONTENTS

DRAWER 1 (28PCS):

- 11Pc - MK-SET-30006: 75° OFFSET DOUBLE RING 6x7, 8x10, 10x12, 12x14, 14x15, 14x17, 17x19, 19x22, 22x24, 24x27, 30x32mm
- 17Pc - MK-SET-30015: FLARE NUT WRENCH 8x10, 12x13, 10x12, 12x14, 14x17, 17x19mm
DOUBLE RING END WRENCH 6x7, 8x9, 10x11, 12x13, 14x15, 16x17, 18x19, 20x22, 21x23, 24x27, 30x32mm

DRAWER 2 (26PCS):

- 6Pc - MK-SET-30008: LOCKING PLIERS 10", COMBINATION PLIERS 7", DIAGONAL PLIERS 6", LONG NOSE PLIERS 8", WATER PUMP PLIERS 10", ADJUSTABLE WRENCH 10"
- 4Pc - MK-SET-30009: 7" SNAP RING PLIERS SS,SB,HS,HB
- 16Pc - MK-SET-30004: COMBINATION WRENCH 6,7,8,9,10,11,12,13,14,15,16,17,18,19,20, 21mm

DRAWER 3 (54PCS):

- 27Pc - MK-SET-30002: ½" DR. SOCKET 8,10,11,12,13,14,15,16,17,18,19,20,21,22,23,24,27,30, 32mm RATCHET HANDLE, FLEXIBLE HANDLE, EXTENSION BAR 75,125,250mm
UNIVERSAL JOINT, SPARK PLUG 16,21mm
- 12Pc - MK-SET-30007: ½" DR. DEEP SOCKET 8,10,11,12,13,14,15,17,19,20,22,24mm
- 15Pc - MK-SET-30014: ½" IMPACT SOCKET 10,12,13,14,17,19,21,22,24,27mm, EXTENSION BAR 250mm,
UNIVERSAL JOINT, DEEP SOCKET (COLOUR) 17,19,21mm

DRAWER 4 (42PCS):

- 12Pc - MK-SET-30012: SCREWDRIVER PH0*75mm, SL3*75mm, PH0*100mm, SL3*100mm, PH1*75mm, SL5*75mm, PH2*38mm, SL6*38mm, PH2*100mm, SL6*100MM, PH2*200MM, SL6*200mm
- 24Pc - MK-SET-30013: ½" BIT DR. SOCKET (T)30,40,45,47,50,55,60,70 (H)5,6,7,8,10,12,14,17 (E)10,12,14,16,18,20,22,24
- 6Pc - MK-SET-30005: DOUBLE END SWIVED HEAD WRENCH 10x11, 10x12, 12x13, 12x14, 14x15, 14x17mm
- 1Pc - 5-DRAWER ROLLER CABINET

Drawer 1

MK-SET-30006



MK-1103

MK-SET-30015



MK-1105M MK-1151M

Drawer 2

MK-SET-30008



MK-1534 MK-1526
MK-1504 MK-1508
MK-1501 MK-1506

MK-SET-30009



MK-1515
MK-1516
MK-1517
MK-1518

MK-SET-30004



MK-1161

Drawer 3

MK-SET-30002



MK-4150NQ MK-4400
MK-4700 MK-4800
MK-4200 MK-4305

MK-SET-30007



MK-4300
MK-4302

MK-SET-30014



MK-84800
MK-84200
MK-84304C
MK-84400

Drawer 4

MK-SET-30012



MK-600
MK-800

MK-SET-30013



MK-4024
MK-4026
MK-4410

MK-SET-30005



MK-1181

ITEM CODE	DESCRIPTION	QTY/CTN	PRICE
MK-EQP-390	151 pcs 5-Drawer Trolley Tools Set	1	5,450.00

MK-SET-303

160 PCS 3-DRAWER TROLLEY TOOLS SET (3 DRAWER WITH TOOLS)



- Cabinet steel thickness (Body: 1.5mm ; Drawer: 0.8mm, Cover 1.0mm)
- Featured with Internal Locking System (MIS) for extra security
- Side handle design for holding tools and etc
- Supplied with 160pcs hand tools kit
- Powdered coating finish to resist scratch
- Suitable for automotive workshop, tire workshop, factory maintenance and other

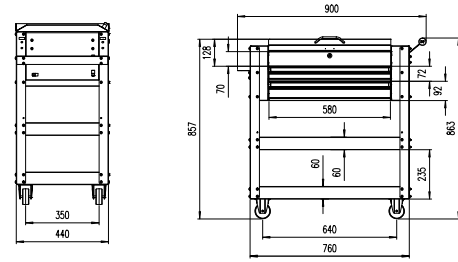

Drawer 1

MK-SET-30002



MK-4120NQ
MK-4700
MK-4200

MK-SET-30001



MK-4400
MK-4800
MK-4305

MK-SET-30003



MK-3700N
MK-3120N
MK-3200

MK-3800
MK-3300M
MK-3400M

MK-2028
MK-2200
MK-2770

Drawer 2

MK-SET-30004



MK-1161

MK-SET-30005



MK-1181

MK-SET-30015



MK-1105M
MK-1151M

Drawer 3

MK-SET-30008



MK-1534
MK-1504
MK-1501

MK-SET-30009



MK-1526
MK-1508
MK-1506

MK-SET-30011



MK-1515
MK-1516
MK-1517
MK-1518

MK-10144
MK-10146
MK-2017

MK-10145
MK-10147

CONTENTS

DRAWER 1 (100PCS):

- 27Pc - MK-SET-30002: ½" DR. SOCKET 8,10,11,12,13,14,15,16,17,18,19,20,21,22,23,24,27,30,32mm RATCHET HANDLE, FLEXIBLE HANDLE, EXTENSION BAR 75,125,250mm UNIVERSAL JOINT, SPARK PLUG 16,21mm
- 22Pc - MK-SET-30001: 3/8" DR. SOCKET 7,8,9,10,11,12,13,14,15,17,18,19,22MM DEEP SOCKET 10,12,13,14MM, FLEXIBLE HANDLE, RATCHET HANDLE, UNIVERSAL JOINT, EXTENSION BAR 75,150MM
- 51Pc - MK-SET-30003: ¼" DR. SOCKET 4,4.5,5,5.5,6,7,8,9,10,11,12,13mm, DEEP SOCKET 8,9,10,11,12,13mm, EXTENSION BAR 2",4", RATCHET HANDLE, SNAKE BAR, UNIVERSAL JOINT, SLIDING T BAR, SPINNER HANDLE, BIT SOCKET (+)1,2, (-)4,5,5,7, PZ1, PZ2, (T)8,10,15,20,25,30, (H)3,4,5,6 BALL POINT HEX KEY 1.5,2,2.5,3,4,5,6,8,10mm

DRAWER 2 (39PCS):

- 16Pc - MK-SET-30004: COMBINATION WRENCH 6,7,8,9,10,11,12,13,14,15,16,17,18,19,20,21mm
- 6Pc - MK-SET-30005: DOUBLE END SWIVED HEAD WRENCH 10x11, 10x12, 12x13, 12x14, 14x15, 14x17mm
- 17Pc - MK-SET-30015: FLARE NUT WRENCH 8x10, 12x13, 10x12, 12x14, 14x17, 17x19mm DOUBLE RING END WRENCH 6x7, 8x9, 10x11, 12x13, 14x15, 16x17, 18x19, 20x22, 21x23, 24x27, 30x32mm

DRAWER 3 (20PCS):

- 6Pc - MK-SET-30008: LOCKING PLIERS 10", COMBINATION PLIERS 7", DIAGONAL PLIERS 6", LONG NOSE PLIERS 8", WATER PUMP PLIERS 10", ADJUSTABLE WRENCH 10"
- 4Pc - MK-SET-30009: 7" SNAP RING PLIERS SS,5B,HS,HB
- 10Pc - MK-SET-30011: CAPE CHISEL 7MM, TAPE CHISEL 3*120MM, 4*120MM, 5*120MM COLD CHISEL 10,24MM, PIN POUCH 2*115MM, 3*125MM, 4*150MM MACHINIST HAMMER 500G
- 1Pc - 3-DRAWER DETACHABLE TOOL CART

ITEM CODE	DESCRIPTION	QTY/CTN	PRICE
MK-SET-303	160 pcs 3-Drawer Trolley Tools Set	1	2,980.00

MK-SET-300

168 PCS 6-DRAWER TROLLEY TOOLS SET (4 DRAWER WITH TOOLS)



- Cabinet steel thickness (Body: 1.2mm ; Drawer: 1.0mm)
- Featured with Internal Locking System (MIS) for extra security and
- Supplied with 118pcs hand tools kit
- Anti-vibration rubber mat on top
- Powdered coating finish to resist scratch
- Suitable for automotive workshop, tire workshop, factory maintenance and other

CONTENTS	
COMBINATION WRENCH (12 PCS):	
• 1Pc - MK-SET-30019:	COMBINATION SPANNER 6,8,10,12,13,14,17,19,21,24,30,32mm
PILERS (5 PCS):	
• 1Pc - MK-SET-30020:	LOCKING PLIERS 10", LINESMAN PLIERS 6", LONG NOSE PLISER 5", WATER PUMP PLIER 10", DIAGONAL PLIERS 6", H/DUTY ADJUSTABLE WRENCH 8"
SCREWDRIVER (11PCS):	
• 1Pc - MK-SET-30021:	SCREWDRIVER BLACK TP 150*6mm, 100*6mm, 100*5mm, 75*3mm, 38*6mm, SCREWDRIVER SOCKET 75*8mm
DOUBLE OPEN END WRENCH (18PCS):	
• 1Pc - MK-SET-30022:	DOUBLE OPEN END WRENCH 6x7, 8x9, 10x11, 12x13, 14x15, 16x17, 18x19, 20x22,21x23, 22x24, 30x32mm
DOUBLE OFFSET RING WRENCH (11PCS):	
• 1Pc - MK-SET-30023:	DOUBLE RING WRENCH 6x7, 8x9, 10x11, 12x13, 14x15, 16x17, 18x19, 20x22,21x23, 22x24, 30x32mm
DOUBLE BOX & FLARE NUT WRENCH (10PCS):	
• 1Pc - MK-SET-30024:	DOUBLE BOX SOCKET 8x9, 10x11, 12x13, 14x15, 17x19, 21x23, FLARE NUT WRENCH 8x9, 10x11, 12x13, 14x17
SOCKET ACCESSORIES (10PCS):	
• 1Pc - MK-SET-30025:	1/2" 6 POINT SOCKET 8,10,11,12,13,14,15,16,17,18,19,20,21,22,23,24,27,30, 32mm 3/4" 6 POINT SOCKET 7,8,9,10,11,12,13,14,15,16,17,19,21mm 1/2" DR. SOCKET 4,5,6,7,8,9,10,11,12,13mm, 1/4" DR. DEEP SOCKET 8,9,10,11,12,13mm 1/2" QUICK RELEASE 250mm, QICK RELEASE RATCHET HANDLE, 1/4" RATCHET HANDLE, 1/4" EXTENSION BAR 75mm EXTENSION BAR, 1/2" EXTENSION BAR 125,250,300,380 mm, 9PCS HEX KEY WRENCH SET, 1/2" x 3/8" ADAPTOR, 12' MEASURING TAPE

Drawer 1



MK-1161



MK-TOL-1526
MK-TOL-1501
MK-TOL-1504
MK-TOL-1506
MK-TOL-1508
MK-TOL-1534

Drawer 2



MK-TOL-600
MK-TOL-610
40 pcs Bit Set



MK-1151
MK-1195

Drawer 3



MK-1103



MK-1181
MK-1105

Drawer 4



MK-2300
MK-2400
MK-3400
MK-4400
MK-TOL-4120NQ
MK-TOL-3120NQ
MK-TOL-2120NQ
MK-TOL-2800
MK-TOL-3800
MK-TOL-4800
MK-TOL-4700N
MK-TOL-3504M
MK-TOL-4804
MK-TOL-9028A

ITEM CODE	DESCRIPTION	QTY/CTN	PRICE
MK-SET-300	168 pcs 6-Drawer Trolley Tools Set	1	5951.80

MK-SET-304

118 PCS 3-DRAWER TROLLEY TOOLS SET (3 DRAWER WITH TOOLS)

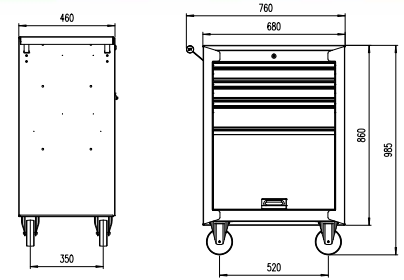

- Cabinet steel thickness (Body: 1.2mm ; Drawer: 1.0mm)
- Featured with Internal Locking System (MIS) for extra security and
- Supplied with 118pcs hand tools kit
- Anti-vibration rubber mat on top
- Powdered coating finish to resist scratch
- Suitable for automotive workshop, tire workshop, factory maintenance and other

CONTENTS	
DRAWER 1 (63 PCS):	
• 27Pc - MK-SET-30002:	1/2" DR. SOCKET 8,10,11,12,13,14,15,16,17,18,19,20,21,22,23,24,27,30, 32mm RATCHET HANDLE, FLEXIBLE HANDLE, EXTENSION BAR 75,125,250mm UNIVERSAL JOINT, SPARK PLUG 16,21mm
• 12Pc - MK-SET-30007:	1/2" DR. DEEP SOCKET 8,10,11,12,13,14,15,17,19,20,22,24mm
• 24Pc - MK-SET-30013:	1/2" BIT DR. SOCKET (T)30,40,45,47,50,55,60,70 (H)5,6,7,8,10,12,14,17 (E)10,12,14,16,18,20,22,24
DRAWER 2 (34 PCS):	
• 16Pc - MK-SET-30004:	COMBINATION WRENCH 6,7,8,9,10,11,12,13,14,15,16,17,18,19,20, 21mm
• 6Pc - MK-SET-30005:	DOUBLE END SWIVED HEAD WRENCH 10x11, 10x12, 12x13, 12x14, 14x15, 14x17mm
• 17Pc - MK-SET-30015:	FLARE NUT WRENCH 8x10, 12x13, 10x12, 12x14, 14x17, 17x19mm DOUBLE RING END WRENCH 6x7, 8x9, 10x11, 12x13, 14x15, 16x17, 18x19, 20x22, 21x23, 24x27, 30x32mm
• 12Pc - MK-SET-30012:	SCREWDRIVER PH0*75mm, SL3*75mm, PH0*100mm, SL3*100mm, PH1*75mm, SL5*75mm, PH2*38mm, SL6*38mm, PH2*100mm, SL6*100MM, PH2*200MM, SL6*200mm
DRAWER 3 (20PCS):	
• 6Pc - MK-SET-30008:	LOCKING PLIERS 10", COMBINATION PLIERS 7", DIAGONAL PLIERS 6", LONG NOSE PLIERS 8", WATER PUMP PLIERS 10", ADJUSTABLE WRENCH 10"
• 4Pc - MK-SET-30009:	7" SNAP RING PLIERS SS,SB,HS,HB
• 10Pc - MK-SET-30011:	CAPE CHISEL 7MM, TAPE CHISEL 3*120MM, 4*120MM, 5*120MM COLD CHISEL 10,24MM, PIN POUCH 2*115MM, 3*125MM, 4*150MM MACHINIST HAMMER 500G
• 1Pc -	3-DRAWER ROLLER CABINET

Drawer 1

MK-SET-30002



- MK-4120NQ
- MK-4700
- MK-4200
- MK-4400
- MK-4800
- MK-4305

MK-SET-30007



- MK-4300
- MK-4302

MK-SET-30013



- MK-4024
- MK-4026
- MK-4410

Drawer 2

MK-SET-30004



MK-1161

MK-SET-30005



MK-1181

MK-SET-30012



MK-600

MK-800

Drawer 3

MK-SET-30008



- MK-1534
- MK-1504
- MK-1501

- MK-1526
- MK-1500
- MK-1506

MK-SET-30009



- MK-1515
- MK-1516
- MK-1517
- MK-1518

MK-SET-30011



- MK-10144
- MK-10146
- MK-2017
- MK-10145
- MK-10147

ITEM CODE	DESCRIPTION	QTY/CTN	PRICE
MK-SET-304	118 pcs 3-Drawer Trolley Tools Set	1	3,300.00

MK-EQP-386 44 PCS 3-DRAWER TROLLEY TOOLS SET (2 DRAWER WITH TOOLS)

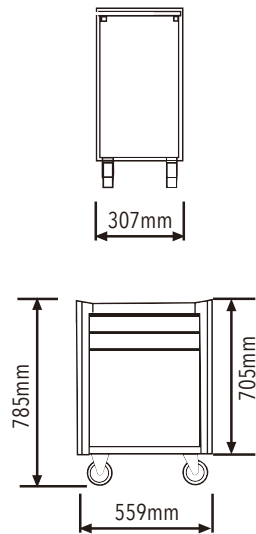

Drawer 1
MK-SET-30017

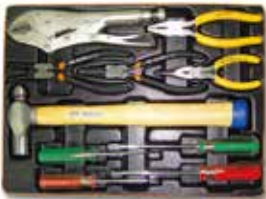

Drawer 2
MK-SET-30018



- Cabinet steel thickness (Body: 1.2mm ; Drawer: 1.0mm)
- Featured with Internal Locking System (MIS) for extra security and
- Supplied with 28pcs hand tools kit
- Featured with 2.5" swivel caster for easy moving
- Powdered coating finish to resist scratch
- Suitable for bicycle and motorcycle repair works

CONTENTS

DRAWER 1 (10 PCS):

- 10Pc - MK-SET-30017: 7" SNAP RING PLIERS SS,HS
LOCKING PLIERS 10"
COMBINATION PLIERS 6"
LONG NOSE PLIERS 5"
BALL PEIN HAMMER 1LB
SCREWDRIVER PH1*75MM, SL5*75MM, PH2*125MM, SL6*125MM

DRAWER 2 (33 PCS):

- 33Pc - MK-SET-30018: COMBINATION WRENCH 8, 10, 12, 14, 17, 19MM
NIPPLE WRENCH 10x11MM
45' DOUBLE RING WRENCH 8x10, 12x14, 17x19MM
1/2" IMPACT DRIVER KIT
HEX KEY 2.5, 3, 4, 5, 6, 8, 10MM
1/2" DR. SOCKET 8, 10, 12, 14, 17, 19MM
DEEP SOCKET 8, 10, 12, 14, 17, 19MM
L-HANDLE 260MM
QUICK RELEASE RATCHET HANDLE 250MM
EXTENSION BAR 75MM
- 1Pc - 3-DRAWER ROLLER CABINET

MK-SET-042 26 PCS POLYESTER BAG TOOLS SET*



CONTENTS

- 1 Unit - MK-EQP-042: POLYESTER H/DUTY TOOL BAG WITH 7 ATTACHMENT/S/
- 1 Set - MK-TOL-3375: 9 PCS HEX KEY WRENCH SET (MM SIZE)
- 1 Pc - MK-CON-9020: 25' MEASURING TAPE (7.5M)/F/
- 1 Pc - MK-TOL-1559: 7 1/2" TOOL SHERAS
- 1 Pc - MK-TOL-1534-12: 1/2" H/DUTY ADJUSTABLE WRENCH(SAND)/S/
- 1 Pc - MK-TOL-1533-14: 8" WATER PUMP PLIER (2 COLOR DIP, ORG & BLK)
- 1 Pc - MK-TOL-2006: 27MM FIBERGLASS HANDLE CLAW HAMMER/S/
- 1 Pc - MK-TOL-1532-085: 8" LINESMAN PLIER (TPR HANDLE)
- 1 Pc - MK-TOL-1534-06: 6" DIAGONAL PLIER (2 COLOR DIP, ORG & BLK)
- 1 Pc - MK-TOL-200-M6-150: 150MM X 6MM COL. LINE S/DRIVER (-)/S/
- 1 Pc - MK-TOL-200-M6-150/+/: 150MM X 6MM COL. LINE S/DRIVER (+)/S/
- 1 Pc - MK-TOL-200-M6-200: 200MM X 6MM COL. LINE S/DRIVER (-)/S/
- 1 Pc - MK-TOL-200-M6-200/+/: 200MM X 6MM COL. LINE S/DRIVER (+)/S/
- 1 Pc - MK-TOL-200-M6-038 38MM X 6MM COL. LINE S/DRIVER (-)/S/
- 1 Pc - MK-TOL-200-M6-038/+/: 38MM X 6MM COL. LINE S/DRIVER (+)/S/
- 1 Pc - MK-CON-9026: BUILDERS LEVEL (TM07)/F/
- 1 Pc - MK-CON-9022-18: 18" BUILDERS LEVEL (96B)/F/
- 1 Pc - MK-CON-9012-150: 150MM MASTER UTILITY CUTTER (ZINC-ALLOY)/F/
- 1 Pc - MK-TOL-1527-S10: 2 IN 1 MULTI-TOOL STRAIGHT & CABLE CUTTER

ITEM CODE	DESCRIPTION	QTY/CTN	PRICE
MK-SET-042	26pcs POLYESTER BAG TOOLS SET	1	760.10

MK-SET-30001 22PCS TOOLS TRAY

- MK-4700
- MK-31200
- MK-3200
- MK-3800 3", 6",
- MK-3300 10, 12, 13, 14
- MK-3400 7, 8, 9, 10, 11, 12, 13, 14, 15, 17, 18, 19, 22



ITEM CODE	DESCRIPTION	QTY/CTN	PRICE
MK-SET-30001	22 pcs Tools Tray	1	270.10

ITEM CODE	DESCRIPTION	QTY/CTN	PRICE
MK-EQP-386	44pcs 3-Drawer Trolley Tools Set	1	1,707.70

MK-SET-30002

27PCS TOOLS TRAY

MK-4150NQ
 MK-4400 8, 10, 11, 12, 13, 14,
 15, 16, 17, 18, 19, 20,
 21, 22, 23, 24, 27,
 30, 32
 MK-4700
 MK-4800 3", 5", 10"
 MK-4200
 MK-4305 16, 21



ITEM CODE	DESCRIPTION	QTY/CTN	PRICE
MK-SET-30002	27 pcs Tools Tray	1	493.10

MK-SET-30004

16PCS TOOLS TRAY

MK-1161
 6, 7, 8, 9, 10, 11,
 12, 13, 14, 15, 16,
 17, 18, 19, 20, 21,
 22, 23



ITEM CODE	DESCRIPTION	QTY/CTN	PRICE
MK-SET-30004	16 pcs Tools Tray	1	332.00

MK-SET-30006

11PCS TOOLS TRAY

MK-1103
 6 X 7, 8 X 10,
 10 X 12, 12 X 14,
 14 X 15, 14 X 17,
 17 X 19, 19 X 22,
 22 X 24, 24 X 27,
 30 X 32



ITEM CODE	DESCRIPTION	QTY/CTN	PRICE
MK-SET-30006	11 pcs Tools Tray	1	477.70

MK-SET-30008

6PCS TOOLS TRAY

MK-1534 10"
 MK-1526 10"
 MK-1504 8"
 MK-1510 6"
 MK-1501 7"
 MK-1506 10"



ITEM CODE	DESCRIPTION	QTY/CTN	PRICE
MK-SET-30008	6 pcs Tools Tray	1	198.00

MK-SET-30003

51PCS TOOLS TRAY

MK-2400 4, 5, 6, 7, 8, 9,
 10, 11, 12, 13
 MK-2150
 MK-2300
 MK-2800 3", 5"
 MK3505



ITEM CODE	DESCRIPTION	QTY/CTN	PRICE
MK-SET-30003	51 pcs Tools Tray	1	252.40

MK-SET-30005

6PCS TOOLS TRAY

MK-1181
 10 X 11, 10 X 12,
 12 X 13, 12 X 14,
 14 X 15, 14 X 17



ITEM CODE	DESCRIPTION	QTY/CTN	PRICE
MK-SET-30005	6 pcs Tools Tray	1	215.20

MK-SET-30007

12PCS TOOLS TRAY

MK-4300 / 4302
 8, 10, 11, 12, 13, 14, 15,
 17, 19, 20, 22, 24



ITEM CODE	DESCRIPTION	QTY/CTN	PRICE
MK-SET-30007	12 pcs Tools Tray	1	199.10

MK-SET-30009

4PCS TOOLS TRAY

MK-1515 7"
 MK-1516 7"
 MK-1517 7"
 MK-1518 7"



ITEM CODE	DESCRIPTION	QTY/CTN	PRICE
MK-SET-30009	4 pcs Tools Tray	1	163.20

MK-SET-30010
5PCS TOOLS TRAY

MK-1161
22, 24, 37, 30, 32



ITEM CODE	DESCRIPTION	QTY/CTN	PRICE
MK-SET-30010	5 pcs Tools Tray	1	311.60

MK-SET-30011
10PCS TOOLS TRAY

CAPE CHISEL 7MM
TAPE CHISEL 4MM
CENTER POUCH NO.2
COLD CHISEL 10MM, 24MM
MK-2017 500GM
PIN POUCH 3, 4, 5MM



ITEM CODE	DESCRIPTION	QTY/CTN	PRICE
MK-SET-30011	10 pcs Tools Tray	1	217.40

MK-SET-30012
12PCS TOOLS TRAY

MK-600 6X200 ⊕⊖
MK-600 6X100 ⊕⊖
MK-600 5X75 ⊕⊖
MK-600 3X100 ⊕⊖
MK-600 3X75 ⊕⊖
MK-600 6X38 ⊕⊖



ITEM CODE	DESCRIPTION	QTY/CTN	PRICE
MK-SET-30012	12 pcs Tools Tray	1	221.40

MK-SET-30013
24PCS TOOLS TRAY

TORX BIT SOCKET
T30, T40, T45, T47, T50,
T55, T60, T70
1-2" DR HEX BIT SOCKET
H5, H6, H7, H8, H10, H12,
H14, H17
1/2" DR E-STAR SOCKET
E10, E12, E14, E16, E18,
E20, E22, E24



ITEM CODE	DESCRIPTION	QTY/CTN	PRICE
MK-SET-30013	24pcs Tools Tray	1	216.00

MK-SET-30014
15PCS TOOLS TRAY

1/2" DR X 10 IMPACT EXT.
1/2" DR. IMPACT U.J
DEEP IMPACT COLOR
SOCKET
17, 19, 21MM
1/2" DR. IMPACT SOCKET
10, 12, 13, 14, 17, 19, 21, 22,
24, 27MM



ITEM CODE	DESCRIPTION	QTY/CTN	PRICE
MK-SET-30014	15 pcs Tools Tray	1	477.70

MK-SET-30015
17PCS TOOLS TRAY

MK-1105M
8 X 10, 11 X 13, 10 X 12,
12 X 14, 15 X 17, 19 X 21
MK-1151M
6 X 7, 8 X 9, 10 X 11, 12 X 13,
14 X 15, 16 X 17, 18 X 19, 20 X 22,
21 X 23, 24 X 27, 30 X 32



ITEM CODE	DESCRIPTION	QTY/CTN	PRICE
MK-SET-30015	17 pcs Tools Tray	1	476.30



PNEUMATIC TOOLS

Pneumatic Tools Safety Instruction

- Air Supply & Connection Hazards:
 - Use only air supply from air compressor. DO NOT use other air supply such as home gas & etc
 - USE recommended air pressure (at the tool). Excessively high pressure than recommended level may ruin the tools. Install air dryer and filter to remove dust and moisture
 - Air under pressure can cause severe injury.
 - Disconnect tool from an supplier before assembling or replacing.
 - Be sure that the switch is at "OFF" position before connecting to air supply system.
 - Always shut off air supply, drain hose of air pressure and disconnect the tool from the air supply when not in use, before changing accessories or when making repairs.
 - Never direct air at yourself or anyone else.
 - Whipping hoses can cause serious injury, Always check for damaged or loose hoses and fittings.
 - Do not use quick disconnect couplings at tool. see instrution for correct set-up.
 - Whenever universal twist couplings are used, lock pins must be installed

- Handling the machine:
 - Shut off the compressed air at the compressor when finished work. Stop the rotation of the tool and air supply when replace tip tools
 - DO NOT use hand tool application tools as it will cause damage and serious accident. Choosing proper bits and adaptor for air tools.
 - DO NOT touch the rotational areas of the machine in use as injury may occurred.

- Installing the tip tools
 - Disconnect air hose from the tool when replacing or installing tip tool

- Air screwdriver
 - Use bits and socket for power tool application

- Air impact wrench
 - Use bits and socket for power tool application

- Air nipper & blade
 - Replace broken blade as this may cause serious damage.
 - Replace blade of the heat nippers & aware of heat even power off



- Air micro grinder
 - Choose proper tip tools
 - DO NOT use broken grindstones.
 - DO NOT use grindstones with different shaft diameter
 - Avoid over tightening and tightening the collet without shaft of the tip tool.



Air Line 3pc. Combined Set:

1. Filter :

To eliminate the moisture and dirt articles from air line to the tool.



2. Regulator :

To adjust the air volume for correct and recommended pressure to the tool.

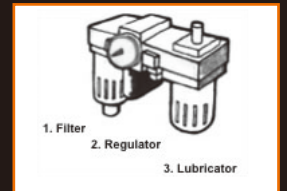

3. Lubricator :

Our air tools need the lubrication periodically for correct performance of the tool.

Recommended oil : ISO-VG10 or equivalent.

Air Compressor:

- Choose the air compressor to supply enough air pressure and flow consumption volume.
- Check periodically to remove the drain water to be free from rusting and possible troubles of air tools.



Air Hose Couplings:

- Connection tool between air hose and air tool or between air hoses.
- Choose the one with better air flow so that prevent decreasing air pressure and lack of it.
- Make sure to mount the connection tight and put the sealing on the screw part.
- Coupling can connect socket and plug by one touch. You can select from our own manufactured couplings. See other pages for the details.



Air Hose:

- Air supply hoses are made of rubber, urethane, nylon and so on.
- Choose the proper one by pressure resistance, length, and diameter size.
- Use the regulator to adjust the air pressure for tools.





MK-EQP-0502 1/2" TWIN HAMMER AIR IMPACT WRENCH

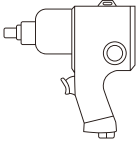

Square Drive	1/2"
Capacity Bolt Size	in: 5/8 "
	mm: 16
Free Speed (RPM)	7000
Exhaust System	Upward
Max. Torque (ft-lb)	410
Sound Level dB(A)	96
Vibration m/s ²	9.0
Air Pressure (PSI)	90
Air Inlet (NPT)	1/4"
Avg. Air Cons. (CFM)	7
Net Weight (Kgs)	2.6

- Twin Hammer mechanism for powerful, durable, balance impact.
- Heavy industrial duty with professional design.
- For general automotive, light truck pads, body shop, tire shop works.

ITEM CODE	DESCRIPTION	QTY/CTN	PRICE
MK-EQP-0502	1/2" Twin Hammer Air Impact Wrench	5	440.00

MK-EQP-05023 1/2" HEAVY DUTY TWIN HAMMER IMPACT WRENCH

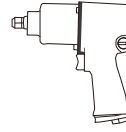

Square Drive	1/2" (12.70mm)
Capacity Bolt Size	in: 9/16 "
	mm: 14
Free Speed (RPM)	8,000
Exhaust System	Downward
Working Torque (ft-lb) (NM)	25-400 (34-540)
Max. Torque (ft-lb) (NM)	560 (759)
Opening Air Pressure PSI (bar)	90 (6.2)
Avg. Air Cons. CFM (l/min)	7.1 (200)
Vibration m/s ²	30.7 (working)
Sound Pressure Value (dBA)	99.9 (working)
Length (mm)	185
Net Weight lbs(kgs)	5.72 (2.6)
Air Inlet Size inch-NPT/PT	1/4" PT
Min. Hose Size inch(mm)	3/8 (10)

- Twin Hammer Impact Wrench.
- Heavy Duty for professional uses such as automotive, light truck, industrial, tire shop.
- The pneumatic motor with high effect designed, low consumption and high torque output.
- Spherulitic iron cylinder with heat treatment and high hardness, durable and long lifespan, torque and output steadily.
- High strength hammer mechanism.
- Two-piece construction for easy maintain.
- 5 steps adjustable power regulator.
- Handle Exhaust, low noise, meanwhile avoid the dust resilience.

ITEM CODE	DESCRIPTION	QTY/CTN	PRICE
MK-EQP-05023	1/2" Heavy Duty Twin Hammer Impact Wrench	8	540.00

MK-EQP-0505 1/4" DIE GRINDER



Free Speed (RPM)	22000
Capacity Bolt Size	in 1/4 "
	mm 6
Sound Level dB(A)	92
Vibration m/s ²	8.1
Air Inlet (NPT)	1/4"
Avg. Air Cons. (CFM)	4
Air Exhaust Style	Rear
Air Pressure (PSI)	90
Net Weight (Kgs)	0.55

- Mold repair.
- Grinding for inside and outside.
- All kinds metal, stone engraving and grinding.
- High speed accurate rotating.
- Low vibration.
- For tire scuffing, cleaning, tire molding.

ITEM CODE	DESCRIPTION	QTY/CTN	PRICE
MK-EQP-0505	1/4" Die Grinder	20	117.80

MK-EQP-0506 1/4" AIR DIE GRINDER KIT SET



- Mold repair.
- Grinding for inside and outside.
- All kinds metal, stone engraving and grinding.
- High speed accurate rotating.
- Low vibration.
- Supplied with 1PC 1/8" chuck collet, 2pcs spanners, 1 pc nipple, 10 pcs grinding stones (5 pcs for 1/4" chuck, 5 pcs for 1/8" chuck)

ITEM CODE	DESCRIPTION	QTY/CTN	PRICE
MK-EQP-0506	1/4" Air Die Grinder Kit Set	10	189.20



MK-EQP-05066 3/4" AIR IMPACT WRENCH



Square Drive	3/4"
Capacity Bolt Size	in: 1" mm: 27
Free Speed (RPM)	5,800 RPM
Max. Torque (ft-lb) (NM)	1000 ft-lb
Sound Level dB(A)	99 dB
Vibration m/s ²	-
Air Pressure (PSI)	90 psi
Air Inlet (NPT)	3/8"
Average Air Consumption(CFM)	0.38
Net Weight (kgs)	5.45 kgs

- Pin less hammer mechanism allowed power generated will be transferred almost without any loss of power directly to the anvil
- The Pin-Less Impact System is an advanced development absolute wear less and has a very high power performance as well as easy to service
- Made with lightweight, durable aluminium alloy casting housing, the air impact wrench has a convenient reverse valve for easy direction changes-three speeds forward and three speeds reverse
- Ideal for spring work, truck and bus maintenance, farm machinery and construction equipment
- Ultimate Torque: 1000 Ft. lb.

ITEM CODE	DESCRIPTION	QTY/CTN	PRICE
MK-EQP-05066	3/4" AIR IMPACT WRENCH	6	997.90

MK-EQP-0511 3/8" REVERSIBLE AIR DRILL MK-EQP-0512 1/2" REVERSIBLE AIR DRILL

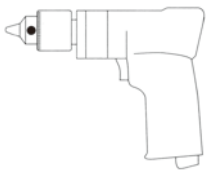

Chuck Size	3/8"	1/2"
Free Speed (RPM)	1800	750
Sound Level dB(A)	86	86
Vibration m/s ²	2.4	2.4
Air Inlet (NPT)	1/4"	1/4"
Avg. Air Cons. (CFM)	4	4
Net Weight (Kgs)	0.9	0.9
Air Pressure (PSI)	90	90

- High efficient output power.
- Planetary gear design for durable.
- Forward/ Reverse adjust for more flexible and comfortable.
- Polished aluminium housing.
- Suitable for general workshop use.

ITEM CODE	DESCRIPTION	QTY/CTN	PRICE
MK-EQP-0511	3/8" Reversible Air Drill	10	255.60
MK-EQP-0512	1/2" Reversible Air Drill	10	604.40

MK-EQP-0509 MICRO AIR GRINDER



Free Speed (RPM)	56000	
Capacity Bolt Size	in	1/8"
	mm	3
Sound Level dB(A)	95	
Vibration m/s ²	1.7	
Air Inlet (NPT)	1/4"	
Avg. Air Cons. (CFM)	7	
Air Exhaust Style	Rear	
Air Pressure (PSI)	90	
Net Weight (Kgs)	0.3	
Packing pcs/N.W./G.W./cuft	20/6Kgs/7Kgs/0.45'	

- Pen type, comfortable operation.
- Rear exhaust design, low noise, reduced users fatigue.
- For mold, cleaning welded.

ITEM CODE	DESCRIPTION	QTY/CTN	PRICE
MK-EQP-0509	Micro Air Grinder	20	506.20

MK-EQP-0513 1/2" AIR DRILL

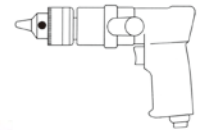

Chuck Size	1/2"
Free Speed (RPM)	800
Sound Level dB(A)	87
Vibration m/s ²	1.6
Air Inlet (NPT)	1/4"
Avg. Air Cons. (CFM)	4
Net Weight (Kgs)	1.76
Air Pressure (PSI)	90

- High efficient output power.
- Planetary gear design for durable.
- Forward/ Reverse adjust for more flexible and comfortable.
- Polished aluminium housing.
- Suitable for general workshop use.

ITEM CODE	DESCRIPTION	QTY/CTN	PRICE
MK-EQP-0513	1/2" Air Drill	10	466.10

MK-EQP-0514A 1/2" AIR RATCHET* MK-EQP-0515 1/2" AIR RATCHET

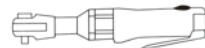

Square Drive	3/8", 1/2"	
Capacity Bolt Size	in	3/8", 1/2"
	mm	10, 13
Free Speed (RPM)	160	
Max. Torque (ft-lb)	50	
Sound Level dB(A)	92	
Vibration m/s ²	10.5	
Air Pressure (PSI)	90	
Air Inlet (NPT)	1/4"	
Avg. Air Cons. (CFM)	4	
Net Weight (Kgs)	1.1	

- Durable improved ratchet head with a convenient forward reverse button for easy operation.
- Compact design high output power, well balance.
- Handle exhaust engaged with 360 degree swivel coupling great flexibility in the narrow space.

ITEM CODE	DESCRIPTION	QTY/CTN	PRICE
MK-EQP-0514A	1/2" Air Ratchet	20	222.80
MK-EQP-0515	1/2" Air Ratchet	20	228.60



MK-EQP-0516 AIR SCREWDRIVER

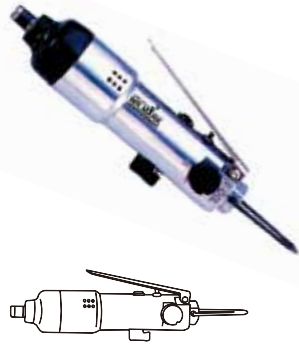

Capacity	5"
Free Speed (RPM)	8000
Max. Torque (ft-lb)	10-60
Sound Level dB(A)	92
Vibration m/s ²	1/4"
Air Inlet (NPT)	1/4"
Avg. Air Cons. (CFM)	4
Net Weight (Kgs)	0.8
Air Pressure (PSI)	90

- Two hammer mechanism offers high efficient fastening works.
- Built-in regulator for fastening works of various capacities of screws.
- Ideal for assembly / dismantling and general production work.

ITEM CODE	DESCRIPTION	QTY/CTN	PRICE
MK-EQP-0516	Air Screwdriver	20	238.50

MK-EQP-0533 ANGLE-FREE ROTATING AIR GREASE GUN

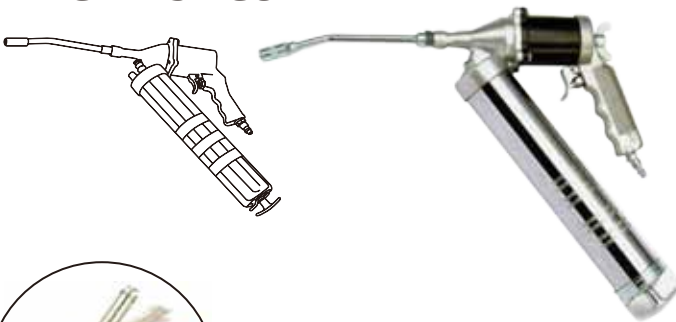

360° Angle-Free rotating selected to meet confine space for active, quick and labor-saving operation.

Special Air Motor design keep incessantly and automatically priming.



Creative Butterfly-Lock Screw equipped to assure the grip handle lock securely.



Capacity	400.(cc).14(oz)
Air Inlet (NPT)	1/4"
Avg. Air Cons. (CFM)	4
Net Weight (Kgs)	1.63

- Worldwide Patent 360 Degree Angle-Free Rotating Handle Design. A new, ergonomic design, this pneumatic grease gun gives added flexibility to get any grease fitting.
- Special "Grip handle" designs for allowing it to do Angle-Free Rotating.
- Continuously pumps grease while trigger is depressed.
- Pressure Range: Air supplied input 60-150 psi / output 2,400 ~ 6,000 psi
- Working Pressure: Recommend air supplied input 90 psi / output 3,6000 psi

ITEM CODE	DESCRIPTION	QTY/CTN	PRICE
MK-EQP-0533	Angle-Free Rotating Air Grease Gun	10	214.00

MK-EQP-0517 AIR GREASE GUN



Capacity	400 c.c.14 oz
Air Inlet (NPT)	1/4"
Avg. Air Cons. (CFM)	4
Net Weight (Kgs)	1.3

- Compact design, lightweight, comfortable for operation.
- For industry, car repair workshop.
- Single Shot Air Operated Grease Gun.
- Pressure Range: Air supplied input 60-150 psi / output 2,400 ~ 6,000 psi.
- Working Pressure: Recommend air supplied input 90 psi / output 3,600 psi.

ITEM CODE	DESCRIPTION	QTY/CTN	PRICE
MK-EQP-0517	Air Grease Gun	10	156.90

MK-EQP-0519 DUST DUALACTION SANDER



Sanding Paper	in	5"
	mm	125
Free Speed	11000rpm	
Air Consumption)	14 scfm	
Length	7.28" /18.5cm	
Weight	2 lb / 0.9 kg	
Noise	80 db	
Pad Size	5" (125)	
Diameter Orbit	5mm	
Exhaust	Rear Exhaust	
Vibration m/s ²	0.8	
RPM	11,000	
Air Inlet In.	1/4	
Min. Hose Size in (mm)	3/8 (10)	
Avg. Air Cons CFM	1.6	

- Self-Generated vacuum.
- Compact design, lightweight to reduce users fatigue.
- Low noise, excellent durability.
- High efficient output power.
- Precision air motor with extremely high torque.
- High quality dual action sander designed for the professional bodyshop, garage, paintshop and craftsmen.

ITEM CODE	DESCRIPTION	QTY/CTN	PRICE
MK-EQP-0519	Dust Dualaction Sander	6	690.00



MK-EQP-0542 3" PISTOL ANGLE SANDER*



Free Speed	3500 rpm
Air Pressure	90 psi / 6.21 bar
Weighth	2.53 lb / 1.15 kg
Noise Rating	85 dBA
Pad Size	3 x M6" / 76.2 x M6mm
Orbital Size	3 x M6" / 76.2 x M6mm
Exhaust	Rear
Horse Power	0.5hp / 0.38kw
Hose Size	3/8" / 9.52mm
Tool Length	7.87" / 200mm
Total Angle Height	7.87" / 200mm
Angle Height Above Collect	7.87" / 200mm

- Rubber molded pistol grip provide comfortable uses
- Featured with variable speed trigger
- Handle exhaust
- Compact and lightweight
- Maximise operator control and ergonomics, less fatigue
- Excellent for small area repair
- Ideal for general maintenance

ITEM CODE	DESCRIPTION	QTY/CTN	PRICE
MK-EQP-0542	3" Pistol Angle Sander	10	386.00

MK-EQP-0521 7" AIR ANGLE SANDER*

MK-EQP-0522 7" AIR ANGLE POLISHER*

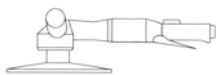

Sanding Paper	in: 7 "
	mm: 178
Spindle Thread (UNF)	5/8"x11UNC
Free Speed (RPM)	4500
Air Inlet (NPT)	1/4"
Avg.Air Cons. (CFM)	6
Air Pressure (PSI)	85
Net Weight (Kgs)	3.9 kg

- Handle mounts on either side, convenient for operation.
- Rear exhaust design, low vibration, durable.
- For heavy rust removal, sanding metal, sharpening of contoured filler patches.

ITEM CODE	DESCRIPTION	QTY/CTN	PRICE
MK-EQP-0521	7" Air Angle Sander	6	718.60
MK-EQP-0522	7" Air Angle Polisher	6	718.60

MK-EQP-0520 4" HEAVY DUTY AIR ANGLE GRINDER

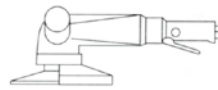

Free Speed (RPM)	11000
Capacity	in: 4"
	mm: 100
Air Inlet (NPT)	1/4"
Avg.Air Cons. (CFM)	6
Net Weight (Kgs)	2.0
Air Pressure (PSI)	90

- Aluminum alloy housing, lightweight, comfortable for operation
- Low noise, reduced users fatigue.
- For body shop, welding clean, rust removal.

ITEM CODE	DESCRIPTION	QTY/CTN	PRICE
MK-EQP-0520	4" Heavy Duty Air Angle Grinder	6	629.80

MK-EQP-0523 250mm HEAVY DUTY AIR HAMMER

Sanding Paper	Round	0.401
	Hex	0.410
Bore Diameter	in	3/4"
	mm	19.05
Stroke Length	in	3-5/8"
	mm	88
Bolw per Min	2200	
Sound Level dB(A)	101	
Vibration m/s2	92	
Air Inlet (NPT)	1/4"	
Avg.Air Cons. (CFM)	6	
Air Pressure (PSI)	90	
Net Weight (Kgs)	1.8	

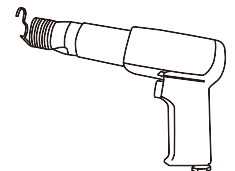

- Longer piston strokes, more force per blow.
- Built-in regulator for easy operation.
- For rivet and bolt cutting, bushing driving, front end.

ITEM CODE	DESCRIPTION	QTY/CTN	PRICE
MK-EQP-0523	250mm Heavy Duty Air Hammer	6	232.80

MK-EQP-0524 HEAVY DUTY AIR RIVETER

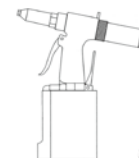

- Suitable for aluminum, steel and stainless steel rivets up to 3/16"
- Ergonomic design, flexible for operation.
- Offers an instant solution to many of your design.
- Ideal for heavy assembly work, sheet metal, general maintenance.

Blind Rivet Setting Cap(in)	3/32" / 1/8" / 5/32" / 3/16"
Traction Power (kg)	1045
Air Inlet (NPT)	1/4"
Avg.Air Cons. (CFM)	0.04
Net Weight (Kgs)	1.52
Air Pressure (PSI)	85

ITEM CODE	DESCRIPTION	QTY/CTN	PRICE
MK-EQP-0524	Heavy Duty Air Riveter	6	481.00

MK-EQP-0525 FINISH BRAD AIR NAILER

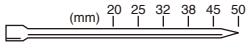

- Lightweight die cast body with rubber grip handle.
- Compact size, flexible and durable for professional uses.
- Ideal for furniture assembly, picture frame, general carpentry, skirting, craftwork, beading, interior finishing and many more.



ITEM CODE	DESCRIPTION	QTY/CTN	PRICE
MK-EQP-0525	Finish Brad Air Nailer	10	674.70

MK-EQP-0527 NARROW CROWN AIR STAPLER

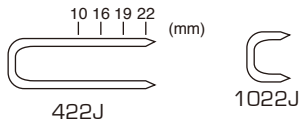

- Lightweight die cast body, reduced users fatigue.
- Compact size, flexible, durable.
- For wood box assembly, furniture manufacturers, upholstery work.



ITEM CODE	DESCRIPTION	QTY/CTN	PRICE
MK-EQP-0527-1022J	Narrow Crown Air Stapler	6	393.80
MK-EQP-0527-422J	Narrow Crown Air Stapler	6	393.80

MK-EQP-05345A 1/2" AIR RATCHET WRENCH*

(MADE IN JAPAN)

(Premier)

Shank Size in./(mm)	1/2/(12.7)
Maximum Torque Nm/(ft-lb)	115/(85)
Working Torque Range Nm/(ft-lb)	0-90/(0-66)
Bolt Cap mm/(in.)	16/(5/8)
Free Speed rpm	160
Weight kg/(lb)	1.15/(2.53)
Over Length mm/(in.)	263/(10.4)
Noise Level dBA/ (power)	89/(102)
Vibration m/s ²	7.6
Avg. Air Consumption CFM	2.5
Air Inlet Size in.	1/4
Hose Size mm/(in)	10/(3/8)



ITEM CODE	DESCRIPTION	QTY/CTN	PRICE
MK-EQP-05345A	1/2" Air Ratchet Wrench	10	632.50

MK-EQP-0526 SLIGHT HEAD AIR NAILER

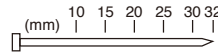

- Lightweight die cast body with rubber grip handle, reduced users fatigue.
- Ideal for furniture assembly, picture frame, general carpentry, panelling, skirtings, craftwork beading, exhibition work and many more.



ITEM CODE	DESCRIPTION	QTY/CTN	PRICE
MK-EQP-0526	Slight Head Air Nailer	6	350.80

MK-EQP-0529A AIR ANGLE GRINDER*

Industrial Grade

Disc Size (in)	4
Free Speed (RPM)	11000 ~ 12000
Air Inlet (NPT)	1/4"
Length	(in) 9-1/2"
	(mm) 232
Weight	(lbs) 4
	(kgs) 1.82
Hose Size (in)	3/8
Avg. Air Cons. (CFM)	4.2
Air Pressure (PSI)	90

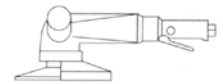

- Aluminum alloy housing, lightweight, comfortable for operation
- Low noise, reduced users fatigue.
- For body shop, welding clean, rust removal.
- Spindle Lock.
- Rear Exhaust.
- Side Handle.

ITEM CODE	DESCRIPTION	QTY/CTN	PRICE
MK-EQP-0529A	4" Air Angle Grinder		1,035.80

MK-EQP-08103 7" HEAVY DUTY AIR ANGLE GRINDER*

Free Speed (RPM)	7,000
Capacity (in/mm)	7/177.8
Air Pressure (PSI)	90
Air Inlet (NPT)	3/8"
Average Air Consumption (CFM)	6
N.W./ G.W. (Kg)	3.7/3.9

- High performance.
- Spiral bevel gearing in angle head provides extended life and smooth low vibration.
- For cleaning, deburring, blending and smoothing.

ITEM CODE	DESCRIPTION	QTY/CTN	PRICE
MK-EQP-08103	7" Heavy Duty Air Angle Grinder		1,385.40

MK-EQP-0549 UTILITY SURFACE BLASTER KIT



• Black Strip Wheel- for removing paint or undercoat.

• Wire Brush- for removing rust

Free Speed	3500rpm
Air Inlet	1/4" NPT
Hose Size	3/8" I.D.
Air Pressure	90 P.S.I.
Average Air Consumption	14.1 CFM
Length	12"
Weight	3-3/16 Lbs
Sound Level	93 dBA

- The Surface Blaster is a high quality versatile tool for removing stickers & adhesive, paint and undercoat, rust and seam sealer
- Easily attached the accessories onto tools with patented adaptor

ITEM CODE	DESCRIPTION	QTY/CTN	PRICE
MK-EQP-0549	Utility Surface Blaster Kit	10	1,785.50

Kit Includes:

- 1pc Utility surface blaster
- 1pc Blow Case

Optional Accessories:

- #0511 11mm Wire Brushes (Fine)
- #0523 23mm Wire Brushes (Fine)
- #0711 11mm Wire Brushes (Coarse)
- #0723 23mm Wire Brushes (Coarse)
- SA-6902RW Rubber Eraser
- SA-6902RWW Water Base Paint Rubber Eraser
- SA-6902RH Adaptor for Rubber Eraser & 23mm Wire Brushes
- SA-6902WH Adapter for 11mm Wire Brushes
- SA-6902BW Black Strip Wheels (up to 6pcs)
- SA-6902BHS Adaptor for Single Black Strip Wheel
- SA-6902BHD Adaptor for Double Black Strip Wheels



Wire Brush Wheels -

For removing liquid gaskets, rust, paint, seam sealer and undercoating back to bare metal in seconds!

Rubber Eraser -

For removing decals / stickers, pinstripes molding tape and adhesive backing from molds and badges

Fibre Discs -

Prepare panels by cleanly removing paint or undercoat with no surface damage

MK-EQP-05760 1" AIR IMPACT WRENCH



Square Drive	1"
Bolt Capacity	1-1/2"
Max. Torque (ft-lb)	3950
Free Speed (RPM)	2400
Average Air Consumption (CFM)	0.38
Air Pressure (PSI)	90
Air Inlet (NPT)	1/2"
Net Weight (Kgs)	17.2

- Built with industrial-duty components which can last long.
- The Pin-Less Impact System is an advanced development absolute wear less and has a very high power performance as well as easy to service
- Made with lightweight, durable aluminium alloy casting housing, the air impact wrench has a convenient reverse valve for easy direction changes-three speeds forward and three speeds reverse
- Featuring an 8" extended anvil and a torque range of 2400 ft. lbs., this tough pneumatic impact wrench works best with a 1/2" hose.
- Lightweight, durable cast aluminium alloy housing
- Convenient reverse valve for easy direction changes
- Three speeds forward, three speeds reverse
- Teasing thrattle for easy bolt starting
- Convenient reverse valve for easy directional changes
- Choice of professional mechanics for high volume tyre work on trucks, buses and heavy equipment

ITEM CODE	DESCRIPTION	QTY/CTN	PRICE
MK-EQP-05760	1" SQ.DR. AIR IMPACT WRENCH W/8.5" Anvil	2	2,750.00

MK-EQP-05778 1" AIR IMPACT WRENCH*



(MADE IN JAPAN)

Clutch	Pin Hammer
Overall Length	656mm
Weight	18.2kgs
Free Speed	3,000rpm
Blows/min	380bpm
Working Torque	1,700 ~ 2700Nm
Max. Torque	3,100 Nm

- Straight body impact wrench with 1"sq. anvil and D handle.
- The twin hammer clutch delivers higher torque and fast power delivery.
- Compact body design for reduced weight.

ITEM CODE	DESCRIPTION	QTY/CTN	PRICE
MK-EQP-05778	1" SQ. DRV Air Impact Wrench	1	4,796.50



MK-EQP-05778S **1" AIR IMPACT WRENCH SHORT ANVIL***



(MADE IN JAPAN)

Clutch	Pin Hammer
Overall Length	476mm
Weight	16.5kgs
Free Speed	3,000rpm
Blows/min	380bpm
Working Torque	1,700 ~ 2700Nm
Max. Torque	3,100 Nm

- Straight body impact wrench with 1"sq.anvil and D handle.
- The twin hammer clutch delivers higher torque and fast power delivery.
- Compact body design for reduced weight.

ITEM CODE	DESCRIPTION	QTY/CTN	PRICE
MK-EQP-05778S	1" SQ. DRV. Air Impact Wrench Short Anvil	1	5,142.50

MK-EQP-05780 **1" HEAVY DUTY AIR IMPACT WRENCH (TWIN HAMMER)***



Square Drive	1"
Bolt Capacity	1-3/4"
Max. Torque (ft-lb)	3000
Free Speed (RPM)	3000
Average Air Consumption (CFM)	10
Air Pressure (PSI)	90
Overall Length (MM)	620
Air Inlet (NPT)	1/2"
Net Weight (Kgs)	18.5

- Two-step trigger function is selective
- Inside or outside trigger are available
- Maintenance free type
- Particularly for construction, mining applications

ITEM CODE	DESCRIPTION	QTY/CTN	PRICE
MK-EQP-05780	1" DRV. Heavy Duty Air Impact Wrench (Twin Hammer)		6,222.80

MK-EQP-05779 **1" HEAVY DUTY AIR IMPACT WRENCH WITH 8" EXTENDED ANVIL***



Square Drive	1"
Bolt Capacity	1-3/4"
Max. Torque (ft-lb)	2500
Free Speed (RPM)	3000
Average Air Consumption (CFM)	10
Air Pressure (PSI)	90
Overall Length (MM)	620
Air Inlet (NPT)	1/2"
Net Weight (Kgs)	17

- Side exhaust
- Inside or outside trigger are available
- Most powerful and durable in the same range of specification compared to competitors
- 8" extended anvil
- Particularly for construction, bus maintenance and truck work applications

ITEM CODE	DESCRIPTION	QTY/CTN	PRICE
MK-EQP-05779	1" Drv. Heavy Duty Air Impact Wrench with 8" Extended Anvil	1	4,211.90

MK-LITE-05024K **16PCS 1/2" LITE SERIES AIR IMPACT WRENCH KIT**

Square Drive	1/2"
Capacity Bolt Size	in: 1/2" mm: 13
Free Speed (RPM)	7000
Exhaust System	-
Max. Torque (ft-lb)	260
Sound Level dB(A)	90
Vibration m/s ²	7
Air Pressure (PSI)	90
Air Inlet (NPT)	1/4"
Avg. Air Cons. (CFM)	3.8
Net Weight (Kgs)	2.2



- Rocking dog mechanism deliver up to 260 ft-ib
- Die cast aluminium body
- Ideal for general assembling work
- Supplied with 1pc 1/2" air impact wrench, 10pcs 1/2" hand sockets: 9,10,11,13,14,17,19,22,24,27mm, 1pc 125mm extension bar, 1pc mini oiler, 1pc plug, 1pc 4mm hex key, 1pc carrying case

ITEM CODE	DESCRIPTION	QTY/CTN	PRICE
MK-EQP-05024K	16pcs 1/2" Lite Series Air Impact Wrench Kit	6	405.00



MK-LITE-0505SK 14PCS LITE SERIES 1/4" MINI AIR DIE GRINDER KIT

Free Speed (RPM)	25000
Capacity Bolt Size	in: 1/4" & 1/8" mm: 3 or 6
Sound Level dB(A)	87
Vibration	3.5
Air Inlet (NPT)	1/4"
Avg. Air Cons. (CFM)	2.4
Air Exhaust Style	Front
Air Pressure (PSI)	90
Net Weight (Kgs)	0.32



- For precision engineer's mould making, tackle projects including weld breaking, smoothing sharp edges, deburring, polishing and grinding.
- Front exhaust, ultra compact and lightweight
- Supplied with 1pc mini air die grinder, 2pcs hand wrench, 1pc 3mm collet, 1pc plug, 5pcs 3mm grinding stones, 5pcs 6mm grinding stones, 1pc carrying case

ITEM CODE	DESCRIPTION	QTY/CTN	PRICE
MK-EQP-0505SK	14pcs Lite Series 1/4" Mini Air Die Grinder Kit	10	190.00

MK-LITE-0515K 16PCS 1/2" LITE SERIES AIR RATCHET KIT

Square Drive	1/2"
Capacity Bolt Size	in: 1/2" mm: 13
Free Speed (RPM)	150
Max. Torque (ft-lb)	50
Sound Level dB(A)	92
Vibration (m/s2)	10.5
Gear Type	3 gear
Air Pressure (PSI)	90
Air Inlet (NPT)	1/4"
Average Air Consumption (CFM)	4
Net Weight (Kgs)	1.2



- Useful for removing and replacing automotive fasteners, replacing struts on a car, tightening down a spring compressor or popping mower blades loose
- Lightweight cast aluminum body
- Compact design with high output power, well balance
- Handle exhaust engaged with 360 degree swivel coupling, great flexibility in the narrow space
- Supplied with 1pc 1/2" air ratchet wrench, 1pc 3" extension bar, 1pc 3" extension bits holder, 1pc 1/2" universal joint, 7pcs 1/2" hand socket: 9,10,11,13,14,17,19mm, 1pc plug, 1pc carrying case

ITEM CODE	DESCRIPTION	QTY/CTN	PRICE
MK-LITE-0515K	16pcs Lite Series 1/2" Air Ratchet Wrench Kit	10	291.00

MK-LITE-0511K 15PCS LITE SERIES 3/8" AIR DRILL KIT

Chuck Size	3/8"
Capacity Bolt Size	9.5mm
Free Speed (RPM)	1800
Sound Level dB(A)	86
Vibration (m/s2)	1.2
Gear Type	3 gear
Air Inlet (NPT)	1/4"
Average Air Consumption (CFM)	4
Air Pressure (PSI)	90
Net Weight (Kgs)	1.1



- Forward/Reverse adjust for more flexible and comfortable
- This air tool also includes a keyed chuck and key to hold a variety of bits for light metal or woodworking projects.
- Perfect for any home hobby shop, professional metalworking or carpentry
- Supplied with 1pc 3/8" Reversible air drill, 1pc drill chuck key, 10pcs H.S.S twist drill bits: 1.5, 2, 2.5, 3, 3.5, 4, 4.5, 5, 5.5, 6 mm, 1pc oil pot, 1pc nipple, 1pc carrying case.

ITEM CODE	DESCRIPTION	QTY/CTN	PRICE
MK-LITE-0511K	15pcs Lite Series 3/8" Air Drill Kit	10	330.00

MK-LITE-0523K 9PCS LITE SERIES 190MM AIR HAMMER KIT

Bore Diameter	in: 0.4" mm:10.2
Stroke Length	in: 2.6" mm: 66
Blow per min3500	Sound Level dB(A)
Vibration	26
Air Inlet (NPT)	1/4"
Avg. Air Cons. (CFM)	3.5
Air Pressure (PSI)	90
Net Weight (Kgs)	1.44



- Fast cutting action on mufflers and tailpipes, body panels and suitable for general repairs
- For cutting, punching or chipping
- Ideal for molding, cutting edges, electrician holding shovel piping
- Supplied with 1pc 190mm air hammer, 5pcs 175mm round chisel, 1pc plug, 1pc spring retainer, 1pc oil pot, 1pc carrying case

ITEM CODE	DESCRIPTION	QTY/CTN	PRICE
MK-LITE-0523K	9pcs Lite Series 190mm Air Hammer Kit	5	310.00

JACKS AND STANDS



Jack Safety Uses

- All jacks - lever and ratchet jacks, screw jacks, and hydraulic jacks must have a device that stops them from jacking up too high. And always be aware of manufacturer's load limit marked on the jack and should not be exceeded.
- A jack should never be used to support a lifted load. Once the load has been lifted, it must immediately be blocked up.
- Use a wooden blocking under the base if necessary to make the jack level and secure. If the lift surface is metal, place a 1-inch-thick hardwood block or equivalent between it and the metal jack head to reduce the danger of slippage.
- To set up a jack, make certain of the following: the base rest of a firm level surface,
 - the jack is correctly centered,
 - the jack head bears against a level surface, and the lift force is applied evenly
 - proper maintenance of jacks is essential for safety.
- All jacks must be inspected before each use and lubricated regularly. If a jack is subjected to an abnormal load or shock, it should be thoroughly examined to make sure it has not been damaged.
- Hydraulic jacks exposed to freezing temperatures must be filled with an adequate antifreeze liquid.
- Malaysian condition does not have freezing temperatures.



MK-EQP-100-10T

10 Ton Body Repair Kit

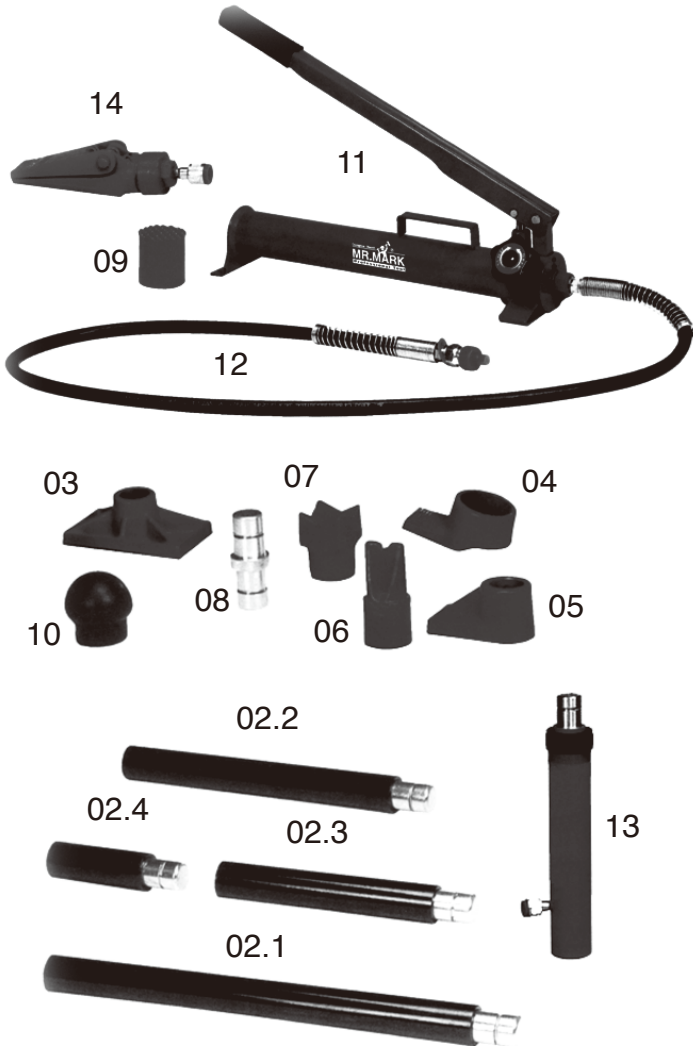

No.	Description	Qty	No.	Description	Qty
01	Metal Case	1	06	Wedge Head	1
02	Extension Tube		07	Square Head	1
	02.1 - 550mm	1	08	Movable Connection	1
	02.2 - 370mm	1	09	Serrated Saddle	1
	02.3 - 300mm	1	10	Rubber Head	1
	02.4 - 200mm	1	11	Pump	1
03	Flat Base	1	12	Hose	1
04	Spreader Ram	1	13	Ram	1
05	Plate Head	1	14	Spreader	1

- Perfect for auto truck body and frame repair
- The complete kit contains all heavy duty equipment needed for lifting, pushing pulling, bending, straightening & spreading minutes.

ITEM CODE	DESCRIPTION	QTY/CTN	PRICE
MK-EQP-100-10T	10 Ton Body Repair Kit	1	1,548.00

MK-EQP-101

TELESCOPIC TRANSMISSION JACK



Capacity (kg)	500
N.W. (kg)	60
G.W. (kg)	63
CUFT	2.8
Low Height	950
High Lift	1890
Chassis Length	810
Chassis Width	670

- Designed for removal, installation and transportation (in the lowered position) of transmissions and transfer cases on passenger cars, vans and light trucks that are raised by an in-ground or above ground lift.
- Foot operated pump and lowering pedal for operator to guide and control the load during transmission removal.
- Foot operated pump and two plunger for maximum speed and accuracy.
- The time required for maximum stroke in the first stage is 10 seconds.
- Lifting the load is accomplished by activating the foot pedal, thus freeing the hand to guide the load.

ITEM CODE	DESCRIPTION	QTY/CTN	PRICE
MK-EQP-101-500kgs	500kg Telescopic Transmission Jack	1	3,661.90

MK-EQP-104

ENGINE CRANE (HOIST) 1 TON



Product Specification:
 Capacity: 1 Ton
 Min. ~ Max. Height: 200~1940mm
 N.W. / G..W.: 80/84kgs

- Perfect for a variety of heavy duty applications.
- Heavy steel construction for maximum durability.
- Features an 8 ton detachable long ram.
- Telescoping boom permits multiple length adjustment.
- Smooth hydraulic lift operation.
- Includes heavy steel hook with safety latch.
- Large roller bearing wheels provide easy maneuvering.
- Wide base for stability.
- Easily disassembles for storage or transport.
- Folds for easy storage or transport, Knock-down design reassembles in minutes.

ITEM CODE	DESCRIPTION	QTY/CTN	PRICE
MK-EQP-104-1T	Engine Cranes (Hoist) 1 Ton	1	1,755.00



MK-EQP-109 10 TON BODY STRAIGHTENER SET

No.	Description	Q'ty
1	10 Ton 6" Stroke Ram	1
2	Frame Assembly	1
3	Pull Camp	2
4	Support Stand	2
5	Underbody Support Clamp	2
6	Multi-Position Anchor Post	1
7	Manual Pump	1
8	Chain and Hook	2
9	Cross-Tube	1
10	Boom	1



- Ideally designed to quickly and precisely straighten badly damaged body and frame.
- Moving range of anchor post with angled pulling is 78°.
- Positioning range of chain on anchor post is 89cm maximum in height.
- Moving range of anchor post with horizontal pull is 15°.
- Length of horizontal beam is 293cm.

ITEM CODE	DESCRIPTION	QTY/CTN	PRICE
MK-EQP-109-10T	10 Ton Body Straightener Set	1	5,627.30

MK-EQP-111-03T 3 TON JACK STAND SET MK-EQP-112-06T 6 TON JACK STAND SET



Model	MK-EQP-111
Capacity	3Ton
Min Height	295mm (11-5/8")
Max Height	425mm (16-3/4")
N.W. (kg)	6.8/Pair
G.W. (kg)	7.5/Pair
Package Size	210x190x360mm (8-1/4"x7-1/2"x14-3/16")

Model	MK-EQP-112
Capacity	6Ton
Min Height	403mm (15-7/8")
Max Height	608mm (24")
N.W. (kg)	14.2/Pair
G.W. (kg)	15.2/Pair
Package Size	300x265x460mm (11-7/8"x10-1/2"x18-3/16")

- Low profile design in order to support forklifts and heavy machinery.
- All stands are sold and intended to be used in pairs.
- Heavy duty adjustment pin is secured to stand to prevent loss.
- Handle provides ease of positioning and carrying.

ITEM CODE	DESCRIPTION	QTY/CTN	PRICE
MK-EQP-111-03T	Jack Stand Set - 3 Ton	2	100.00
MK-EQP-112-06T	Jack Stand Set - 6 Ton	2	180.00

MK-EQP-110 HYDRAULIC BOTTLE JACK



- With large cast iron bases with steel cylinder housing and an adjusting notched saddle.
- Fitted with an overload protection valve.
- Two pieces 'pumping' handle also operates hydraulic release.
- Use on a firm level surface, do not work under the vehicle until another means of support, such as axle stands, are used.
- GS and TUV approved.

ITEM CODE	CAPACITY	MIN HEIGHT	LIFTING HEIGHT	ADJUSTING HEIGHT	BASE PLATE LENGTH & WIDTH	QTY/CTN	PRICE
MK-EQP-110-02T	2 TON	158mm	90mm	60mm	90X94mm (3-3/4"x3-5/8")	10	63.90
MK-EQP-110-04T	4 TON	180mm	110mm	60mm	101X107.5mm (3-15/16"x3-15/16")	5	97.70
MK-EQP-110-06T	6 TON	200mm	125mm	60mm	112X116mm (4-1/16"x4-7/16")	5	120.30
MK-EQP-110-08T	8 TON	205mm	125mm	60mm	119X120.5mm (4-5/16"x4-5/8")	4	155.40
MK-EQP-110-12T	12 TON	214mm	125mm	60mm	135X143mm (3/12"x3-5/8")	2	200.30
MK-EQP-110-20T	20 TON	244mm	215mm	60mm	155X168mm (4-5/8"x4-3/8")	2	259.50

MK-EQP-113 AIR HYDRAULIC BOTTLE JACKS*



- Speedy and versatile air / hydraulic bottle jack makes far quicker than using conventional hand operated hydraulic equipment.
- Much safer because air power permits one handed operation, enable users to watch the load more closely.
- Heavy duty design makes it ideal for a wide range automotive, truck, industrial and construction works.

Item Code	MK-EQP-113-30
Capacity (ton)	30
Low Height (mm)	278
Lift (mm)	163.5
Screw (mm)	80
High Height	451.5
Air Pressure	7-14
N.W. (kg)	29
G.W. (kg)	30

ITEM CODE	DESCRIPTION	QTY/CTN	PRICE
MK-EQP-113-30T	Air Hydraulic Bottle Jacks	1	3,296.20

MK-EQP-114

HYDRAULIC FLOOR JACK (2 Ton)



- Light Weight, easy to carry.
- Safety overload systems to prevent use beyond rated capacity.
- Heat-treated piston and release valve.
- With handle. Rear swivel castors for easy manoeuvring.
- 360° swivel safety saddle.
- Individually tested to 150% of rated capacity.
- GS & CE Std.

Model	MK-EQP-114
Capacity	2 Ton
Min Height	130mm (5-1/8")
Max Height	345mm (13-9/16")
Product Height	469x206x140mm (18-1/2"x8-1/8"x5-1/2")
N.W. (G.W)	9.5kg (10.5kg)

ITEM CODE	DESCRIPTION	QTY/CTN	PRICE
MK-EQP-114-2T	Hydraulic Floor Jack (2 Ton)	1	218.00

MK-EQP-120

LOW PROFILE FLOOR JACK*



- Low Profile 95mm minimum height.
- Steel hydraulic block assembly includes dust seals to prevent oil contamination.
- Removable two piece handle with rubber hand grip provides ease of pumping.
- Safety by-pass system protects pressure cylinder.
- Heavy-duty chassis for added strength and dependability.
- Safety standards conform to ANSI/ASME.

Model	MK-EQP-120
Capacity	3 Ton
Min Height	95mm
Max Height	560mm
Product Size	780 x 366 x 160mm
Package Size	840 x 410 x 205mm
N.W. (G.W)	46 kg (48 kg)

ITEM CODE	DESCRIPTION	QTY/CTN	PRICE
MK-EQP-120-03T	Low Profile Floor Jack	1	1,005.00

TORQUE WRENCH



Torque Wrenches & Torque Multipliers Safety Uses



- Always wear safety glasses to protect eyes.
- Select the socket size according to the standard of a screw or nut.
- Always use a suitable accessory for operation with the socket. Use ratchet for operation requires quickness. Use T handle or flexible handle for final tightening.
- Do not use cheater bars, hammers or other damaging objects.
- Do not exceed rated torque capacity of the wrench.
- Do not exceed the capacity of fastener.
- Do not use a torque wrench to break fasteners loose.
- Pull the wrench towards you. Do not push.
- Do not grind, weld or heat the tools as it could make them unsafe.
- Check the condition of both fasteners of tools before use a commercial lubricant on corroded fastener.
- Be sure to avoid overloading by applying torques beyond rated capacity.
- Never fit an extension as this would modify lever ratios and result in incorrect readings.
- Always store torque wrenches carefully after use.
- Torque wrenches are precision tools. Have yours checked regularly by Mr. Mark inspection facilities.
- Read operating instructions before use.

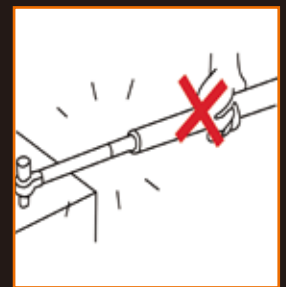
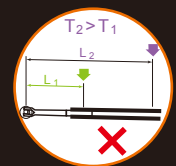
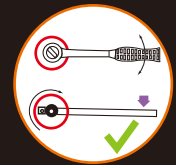

- Never fit an extension to a torque wrench.



- Careful storage and regular inspection



MK-TOL-3170N 3/8" TORQUE WRENCH

3/8"   

- Chrome vanadium steel with proper heat treatment for extra durability and strength
- Fine polished for extra rust resistance
- Heavy duty cam and pawl mechanism with ergonomic handle
- Click type wrench design with reversible feature
- Tolerance of torque +/- 4%.
- Provides scale stamped readings in foot-pounds and Newton-meters

Item Code	dr.	L(mm)	Capacity	g	CTN	Price
MK-TOL-3170N	3/8"	275	5-25NM/3-18FT-LB	580	20	298.00

MK-TOL-3171N 3/8" TORQUE WRENCH

3/8"   

- Chrome vanadium steel with proper heat treatment for extra durability and strength
- Fine polished for extra rust resistance
- Heavy duty cam and pawl mechanism with ergonomic handle
- Click type wrench design with reversible feature
- Tolerance of torque +/- 4%.
- Provides scale stamped readings in foot-pounds and Newton-meters

Item Code	dr.	L(mm)	Capacity	g	CTN	Price
MK-TOL-3171N	3/8"	365	7-112NM/5-80FT-LB	820	20	345.60

MK-TOL-4170N 1/2" TORQUE WRENCH

1/2"   

- Chrome vanadium steel with proper heat treatment for extra durability and strength
- Fine polished for extra rust resistance
- Heavy duty cam and pawl mechanism with ergonomic handle
- Click type wrench design with reversible feature
- Tolerance of torque +/- 4%.
- Provides scale stamped readings in foot-pounds and Newton-meters

Item Code	dr.	L(mm)	Capacity	g	CTN	Price
MK-TOL-4170N	1/2"	460	42-210NM/3-155FT-LB	1340	12	230.00

MK-TOL-4171N 1/2" TORQUE WRENCH

1/2"   

- Chrome vanadium steel with proper heat treatment for extra durability and strength
- Fine polished for extra rust resistance
- Heavy duty cam and pawl mechanism with ergonomic handle
- Click type wrench design with reversible feature
- Tolerance of torque +/- 4%.
- Provides scale stamped readings in foot-pounds and Newton-meters

Item Code	dr.	L(mm)	Capacity	g	CTN	Price
MK-TOL-4171N	1/2"	630	70-350NM/50-250FT-LB	2875	8	450.00

MK-TOL-6170N 3/4" TORQUE WRENCH

3/4"   

- Chrome vanadium steel with proper heat treatment for extra durability and strength
- Fine polished for extra rust resistance
- Heavy duty cam and pawl mechanism with ergonomic handle
- Click type wrench design with reversible feature
- Tolerance of torque +/- 4%.
- Provides scale stamped readings in foot-pounds and Newton-meters

Item Code	dr.	L(mm)	Capacity	g	CTN	Price
MK-TOL-6170N	3/4"	850	70-420NM/50-300FT-LB	3840	6	740.00

MK-TOL-6171N 3/4" TORQUE WRENCH

3/4"   

- Chrome vanadium steel with proper heat treatment for extra durability and strength
- Fine polished for extra rust resistance
- Heavy duty cam and pawl mechanism with ergonomic handle
- Click type wrench design with reversible feature
- Tolerance of torque +/- 4%.
- Provides scale stamped readings in foot-pounds and Newton-meters

Item Code	dr.	L(mm)	Capacity	g	CTN	Price
MK-TOL-6171N	3/4"	1070	140-700NM/100-500FT-LB	6160	4	1,900.00



MK-TOL-900 3/8" INDUSTRIAL TORQUE WRENCH

3/8"

24T, 32T



- Chrome molybdenum steel of Ratchet Head (HRC 48')
- Chrome vanadium steel with proper heat treatment for extra durability and strength
- Fine polished for extra rust resistance
- Heavy duty cam and pawl mechanism with ergonomic rubber handle
- Click type wrench design with reversible feature
- Tolerance of torque +/- 3%
- Provides scale stamped readings in foot-pounds and Newton-meters
- Industrial grade application and quality meets DIN ISO 6789 & ASME B107.14M-1994
- Ideal for wrenching on a small engine, building a bike or putting the finishing touches on an all-out engine rebuild, inspection and quality control in production and any other project which required accurate torque

ITEM NO.	SQUARE DRIVE	TORQUE RANGE		GRADUATION	LENGTH (mm)	WEIGHT (g)	CASE/CTN	PRICE
		Nm	F+lb					
MK-TOL-900A applied 24T	3/8"	4-20	39.81-172.60	0.1	322	650	24	488.10
MK-TOL-900B applied 32T	3/8"	20-100	16.6-71.9	0.5	436	1320	12	582.00

MK-TOL-901 1/2" INDUSTRIAL TORQUE WRENCH

1/2"

32T



- Chrome molybdenum steel of Ratchet Head (HRC 48')
- Chrome vanadium steel with proper heat treatment for extra durability and strength
- Fine polished for extra rust resistance
- Heavy duty cam and pawl mechanism with ergonomic rubber handle
- Click type wrench design with reversible feature
- Tolerance of torque +/- 3%
- Provides scale stamped readings in foot-pounds and Newton-meters
- Industrial grade application and quality meets DIN ISO 6789 & ASME B107.14M-1994
- Ideal for wrenching on a small engine, building a bike or putting the finishing touches on an all-out engine rebuild, inspection and quality control in production and any other project which required accurate torque

ITEM NO.	SQUARE DRIVE	TORQUE RANGE		GRADUATION	LENGTH (mm)	WEIGHT (g)	CASE/CTN	PRICE
		Nm	F+lb					
MK-TOL-901A	1/2"	40-200	33.23-143.80	1.0	512	1580	12	562.80
MK-TOL-901B	1/2"	60-340	51.6-243.4	2.0	614	1800	12	663.90

MK-TOL-902 3/4" INDUSTRIAL TORQUE WRENCH

3/4"

24T



- Chrome molybdenum steel of Ratchet Head (HRC 48')
- Chrome vanadium steel with proper heat treatment for extra durability and strength
- Fine polished for extra rust resistance
- Heavy duty cam and pawl mechanism with ergonomic rubber handle
- Click type wrench design with reversible feature
- Tolerance of torque +/- 3%
- Provides scale stamped readings in foot-pounds and Newton-meters
- Industrial grade application and quality meets DIN ISO 6789 & ASME B107.14M-1994
- Ideal for wrenching on a small engine, building a bike or putting the finishing touches on an all-out engine rebuild, inspection and quality control in production and any other project which required accurate torque

ITEM NO.	SQUARE DRIVE	TORQUE RANGE		GRADUATION	LENGTH (mm)	WEIGHT (g)	CASE/CTN	PRICE
		Nm	F+lb					
MK-TOL-902A	3/4"	100-600	92-424	5.0	1050	5030	2	1,994.30
MK-TOL-902B	3/4"	150-800	129-572	5.0	1240	6110	2	2,622.10

MK-TOL-903 1" INDUSTRIAL TORQUE WRENCH

1"

24T



- Chrome molybdenum steel of Ratchet Head (HRC 48')
- Chrome vanadium steel with proper heat treatment for extra durability and strength
- Fine polished for extra rust resistance
- Heavy duty cam and pawl mechanism with ergonomic rubber handle
- Click type wrench design with reversible feature
- Tolerance of torque +/- 3%
- Provides scale stamped readings in foot-pounds and Newton-meters
- Industrial grade application and quality meets DIN ISO 6789 & ASME B107.14M-1994
- Ideal for wrenching on a small engine, building a bike or putting the finishing touches on an all-out engine rebuild, inspection and quality control in production and any other project which required accurate torque

ITEM NO.	SQUARE DRIVE	TORQUE RANGE		GRADUATION	LENGTH (mm)	WEIGHT (g)	CASE/CTN	PRICE
		Nm	F+lb					
MK-TOL-903A	1"	150-800	129-572	5.0	1240	6230	2	2,698.60
MK-TOL-903B	1"	200-1000	166-719	5.0	1240	6110	2	2,967.90

WRENCHES



Wrenches & Spanners

Safety Uses

- Wear eye protection
- Always use the right size for the fastener head. Do not use metric wrenches on inch fasteners.
- Always use the wrench perpendicularly to the axis of the screw/nut.
- DO NOT use pipe or other extension bar to obtain more torque as there are risk of breaking the wrench.
- DO NOT strike the wrenches unless they are made specifically for this purpose.
- Never exceed the capacity of a tool. Do not use an extension or a hammer with a standard wrench; slogging wrenches are available for that purpose.
- A ring wrench is preferable for high torques. When using an open end wrench, engage fastener head fully to avoid distorting the nose of the wrench, and work in a straight line.
- Pull the wrench towards you. Do not push.

Sensible precautions

- Secure your balance and pull the wrench towards you rather than push it.
- Wear gloves and eye protection.
- Do not grind, weld or heat your tool. It could become unsafe.
- Check condition of both fastener and tool before use.

Correct tool selection - without overload.

- Never exceed tool capacity. Do not use an extension or a hammer with a standard wrench. Slogging wrenches are available for that purpose.
- Always use the right size for the fastener head. No metric wrenches on inch fasteners
- Select a ring wrench for high torques. When using an open-end wrench, engage fastener head fully to avoid distorting the nose of the wrench, and work in a straight line.

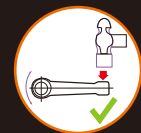
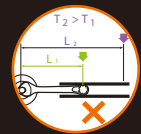
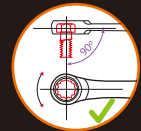
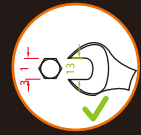

- Always pull wrench towards you



- No metric tools on inch -sizes



- Only fit slogging wrenches

MK-TOL-1310M DEEP SOCKET T-WRENCH

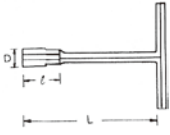

- Chrome vanadium steel with proper heat treatment for extra durability and strength
- Chrome plated finish for extra rust resistance
- Deep socket design to fit most applications.

ITEM CODE	Size (mm)	D (mm)	ℓ (mm)	L (mm)	g	CTN	Price
MK-TOL-1310M-08	8	12	52	300	300	100	25.90
MK-TOL-1310M-09	9	13	52	300	310	100	25.90
MK-TOL-1310M-10	10	14.5	52	300	320	60	25.90
MK-TOL-1310M-11	11	16	52	300	330	60	25.90
MK-TOL-1310M-12	12	17	52	300	340	60	25.90
MK-TOL-1310M-13	13	18.5	52	300	350	50	28.90
MK-TOL-1310M-14	14	20	52	300	360	50	28.90
MK-TOL-1310M-17	17	24	52	300	380	50	33.20
MK-TOL-1310M-19	19	26.5	52	300	390	50	39.00

MK-TOL-1320M SLIDING WRENCH SOCKET

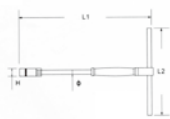

- Chrome vanadium steel with proper heat treatment for extra durability and strength
- Chrome plated finish for extra rust resistance
- Deep socket design to fit most applications.
- Ergonomic rubber grip handle provides comfortable uses

ITEM CODE	Size (mm)	D (mm)	ℓ (mm)	L (mm)	g	CTN	Price
MK-TOL-1320M-08	8	12	52	300	300	50	22.90
MK-TOL-1320M-10	10	14.5	52	300	320	50	22.90
MK-TOL-1310M-12	12	17	52	300	340	50	22.90
MK-TOL-1310M-13	13	18.5	52	300	350	50	22.90
MK-TOL-1310M-14	14	20	52	300	360	50	22.90
MK-TOL-1310M-17	17	24	52	300	380	50	25.10
MK-TOL-1310M-19	19	26.5	52	300	390	50	25.10

MK-TOL-1315M MAGNETIC SPARK PLUG T WRENCH-BALL SWIVEL



- Chrome vanadium steel with proper heat treatment for extra durability and strength
- Chrome plated finish for extra rust resistance
- Universal joint model with ratchet type joint allow pre-setting of socket at desired angle with removable sliding bar
- Extra-long design to avoid burns from engine heat
- Avoids burns from engine heat.

ITEM CODE	Size (mm)	Size (mm)	D (mm)	D2 (mm)	L	L2	g	CTN	Price
MK-TOL-1315M-16	16	5/8	22	10	560	200	540	50	112.10
MK-TOL-1315M-20.8	20.8	13/16	28	12	560	200	800	50	112.10

MK-TOL-1400M SOCKET T-WRENCH

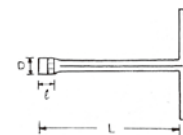

- Chrome vanadium steel with proper heat treatment for extra durability and strength
- Chrome plated finish for extra rust resistance

ITEM CODE	Size (mm)	D (mm)	ℓ (mm)	L (mm)	g	CTN	Price
MK-TOL-1400M-08	8	12	26	250	185	50	26.40
MK-TOL-1400M-09	9	13	26	250	230	50	26.40
MK-TOL-1400M-10	10	14.5	26	250	230	50	27.30
MK-TOL-1400M-11	11	16	26	250	235	50	28.10
MK-TOL-1400M-12	12	17	30	250	380	50	28.10
MK-TOL-1400M-13	13	18.5	32	300	420	50	28.80
MK-TOL-1400M-14	14	20	32	300	435	50	28.80
MK-TOL-1400M-17	17	24	32	300	710	50	38.30
MK-TOL-1400M-19	19	27	32	300	730	50	45.50

MK-TOL-1415M BAII SWIVEL SOCKET T-WRENCH*



- Chrome vanadium steel with proper heat treatment for extra durability and strength
- Chrome plated finish for extra rust resistance
- Universal joint model allow pre-setting of socket t desired angle with removable sliding bar
- Extra-long design to avoid burns from engine heat

ITEM CODE	Size (mm)	D (mm)	D2 (mm)	L (mm)	L1 (mm)		CTN	Price
MK-TOL-1415M-08	8	12	9	330	200	310	40	100.00
MK-TOL-1415M-10	10	14.5	9	330	200	320	40	100.00
MK-TOL-1415M-11	11	16	9	330	200	320	40	100.00
MK-TOL-1415M-12	12	17	9	330	200	330	40	100.00
MK-TOL-1415M-13	13	18.5	10	330	200	410	40	100.00
MK-TOL-1415M-14	14	20	10	330	200	410	40	100.00

MK-TOL-1140M TWO SIZE, RATCHET BOX WRENCH

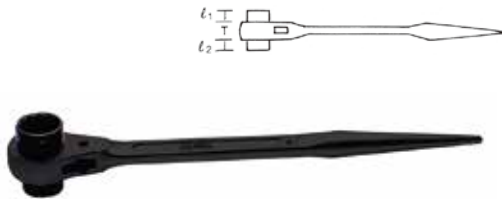

- Chrome vanadium steel with proper heat treatment for extra durability and strength
- Phosphatised finish for extra rust resistance

ITEM CODE	Size (mm)	D1 (mm)	D2 (mm)	T (mm)	L (mm)		Ctn	Price
MK-TOL-1140M-1214	12x14	12	14	15.5	241	214	120	109.80
MK-TOL-1140M-1415	14x15	14	15	16	280	285	80	112.70
MK-TOL-1140M-1417	14x17	14	17	16	280	285	80	112.70
MK-TOL-1140M-1419	14x19	14	19	18	320	500	50	120.10
MK-TOL-1140M-1719	17x19	17	19	18	320	500	50	120.10
MK-TOL-1140M-1721	17x21	17	21	18	320	500	50	120.10
MK-TOL-1140M-1722	17x22	17	22	18	320	500	50	120.10
MK-TOL-1140M-1921	19x21	19	21	18	320	500	50	120.10
MK-TOL-1140M-1922	19x22	19	22	18	320	500	50	170.50
MK-TOL-1140M-1924	19x24	19	24	20	365	840	30	170.50
MK-TOL-1140M-2123	21x23	21	23	20	365	840	30	170.50
MK-TOL-1140M-2126	21x26	21	26	20	365	820	30	170.50
MK-TOL-1140M-2224	22x24	22	24	20	365	820	30	170.50
MK-TOL-1140M-2326	23x26	23	26	20	365	820	30	170.50
MK-TOL-1140M-2427	24x27	24	27	20	365	840	30	170.50
MK-TOL-1140M-2730	27x30	27	30	20	402	1120	20	266.30
MK-TOL-1140M-3032	30x32	30	32	20	402	1120	20	266.30

MK-TOL-1161M (German type DIN3113) COMBINATION WRENCH

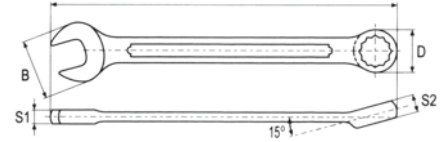

- Chrome vanadium steel with proper heat treatment for extra durability and strength
- Chrome plated finish for extra rust resistance
- 15° open ended head and ring angled design allowed greater access

ITEM CODE	Size (mm)		L (mm)	CTN	Price
MK-TOL-1161M-06	6	17	102	900	13.90
MK-TOL-1161M-07	7	20	112	800	13.90
MK-TOL-1161M-08	8	26	122	500	14.50
MK-TOL-1161M-09	9	35	131	500	14.50
MK-TOL-1161M-10	10	40	140	400	16.00
MK-TOL-1161M-11	11	50	150	300	16.40
MK-TOL-1161M-12	12	59	160	300	17.20
MK-TOL-1161M-13	13	75	170	300	18.30
MK-TOL-1161M-14	14	92	180	200	19.70
MK-TOL-1161M-15	15	95	190	160	21.90
MK-TOL-1161M-16	16	109	200	120	23.20
MK-TOL-1161M-17	17	122	210	100	26.40
MK-TOL-1161M-18	18	149	220	100	27.10
MK-TOL-1161M-19	19	185	230	100	32.40
MK-TOL-1161M-20	20	233	240	100	35.10
MK-TOL-1161M-21	21	209	250	90	38.20
MK-TOL-1161M-22	22	231	260	90	39.60
MK-TOL-1161M-23	23	234	270	60	40.80
MK-TOL-1161M-24	24	274	280	60	44.60
MK-TOL-1161M-25	25	286	290	60	49.00
MK-TOL-1161M-26	26	310	300	50	51.60
MK-TOL-1161M-27	27	330	310	40	69.10
MK-TOL-1161M-28	28	388	320	40	72.30
MK-TOL-1161M-29	29	419	330	40	77.80
MK-TOL-1161M-30	30	474	340	40	84.10
MK-TOL-1161M-31	31	485	350	30	89.80
MK-TOL-1161M-32	32	523	360	30	89.80
MK-TOL-1161M-33	33	972	380	20	124.50
MK-TOL-1161M-34	34	972	380	20	127.40
MK-TOL-1161M-35	35	972	410	20	139.20
MK-TOL-1161M-36	36	1280	410	20	148.00
MK-TOL-1161M-37	37	1280	420	20	178.60
MK-TOL-1161M-38	38	1300	440	20	200.10
MK-TOL-1161M-39	39	1400	440	20	220.10
MK-TOL-1161M-40	40	1500	450	10	234.00
MK-TOL-1161M-41	41	1700	460	10	243.40
MK-TOL-1161M-42	42	1700	460	10	261.70
MK-TOL-1161M-43	43	1700	460	10	283.10
MK-TOL-1161M-44	44	1800	500	10	292.50
MK-TOL-1161M-45	45	1800	500	10	307.50
MK-TOL-1161M-46	46	1800	500	10	354.10
MK-TOL-1161M-47	47	1800	500	10	354.10
MK-TOL-1161M-48	48	2350	540	10	354.10
MK-TOL-1161M-49	49	2350	540	10	397.30
MK-TOL-1161M-50	50	2350	540	10	397.30
MK-TOL-1161M-51	51	2350	540	10	397.30

MK-TOL-1101M

45° Offset German Panel Double Ring Wrench

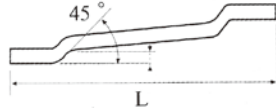

- Chrome vanadium steel with proper heat treatment for extra durability and strength
- Chrome plated finish for extra rust resistance
- 45° oblique design allowed greater access up to 40° narrow space

ITEM CODE	Size (mm)	g	L (mm)	CTN	Price
MK-TOL-1101M-0607	6x7	40	165	500	16.40
MK-TOL-1101M-0608	6x8	40	165	500	16.40
MK-TOL-1101M-0809	8x9	58	180	300	16.90
MK-TOL-1101M-0810	8x10	58	180	300	16.90
MK-TOL-1101M-1011	10x11	73	195	200	19.60
MK-TOL-1101M-1012	10x12	73	195	200	19.60
MK-TOL-1101M-1113	11x13	116	220	120	20.60
MK-TOL-1101M-1213	12x13	116	220	120	20.60
MK-TOL-1101M-1314	13x14	116	220	120	21.10
MK-TOL-1101M-1214	12x14	116	220	120	21.10
MK-TOL-1101M-1415	14x15	134	230	100	25.40
MK-TOL-1101M-1417	14x17	134	230	100	25.40
MK-TOL-1101M-1617	16x17	191	240	80	31.80
MK-TOL-1101M-1719	17x19	269	250	80	31.80
MK-TOL-1101M-1819	18x19	269	250	80	31.80
MK-TOL-1101M-1921	19x21	327	290	60	36.50
MK-TOL-1101M-2022	20x22	327	290	60	36.50
MK-TOL-1101M-2123	21x23	345	320	50	42.44
MK-TOL-1101M-2224	22x24	345	320	50	42.40
MK-TOL-1101M-2326	23x26	517	330	25	58.90
MK-TOL-1101M-2426	24x26	517	360	25	58.90
MK-TOL-1101M-2427	24x27	517	370	25	63.00

MK-TOL-1103M

75° OFFSET GERMAN PANEL DOUBLE RING WRENCH



- Chrome vanadium steel with proper heat treatment for extra durability and strength
- Chrome plated finish for extra rust resistance
- 75° oblique design allowed greater access up to 70° narrow space

ITEM CODE	Size (mm)	g	L (mm)	CTN	Price
MK-TOL-1103M-0607	6x7	43	168	120	21.30
MK-TOL-1103M-0608	6x8	43	168	120	21.30
MK-TOL-1103M-0809	8x9	62	183	120	23.00
MK-TOL-1103M-0810	8x10	62	183	120	23.00
MK-TOL-1103M-1011	10x11	88	198	120	28.10
MK-TOL-1103M-1012	10x12	88	198	120	28.10
MK-TOL-1103M-1113	11x13	131	217	120	30.80
MK-TOL-1103M-1213	12x13	131	217	120	30.80
MK-TOL-1103M-1214	12x14	131	217	120	30.80
MK-TOL-1103M-1314	13x14	152	239	120	35.00
MK-TOL-1103M-1415	14x15	152	239	120	35.70
MK-TOL-1103M-1417	14x17	152	240	120	40.50
MK-TOL-1103M-1617	16x17	189	260	120	40.50
MK-TOL-1103M-1719	17x19	240	292	120	45.40
MK-TOL-1103M-1819	18x19	240	292	120	45.40
MK-TOL-1103M-1921	19x21	240	292	120	53.80
MK-TOL-1103M-1922	19x22	330	318	120	53.80
MK-TOL-1103M-2022	20x22	330	318	120	53.80
MK-TOL-1103M-2122	21x22	436	330	120	58.60
MK-TOL-1103M-2123	21x23	436	330	120	58.60
MK-TOL-1103M-2224	22x24	436	330	120	58.90
MK-TOL-1103M-2326	23x26	436	330	60	65.70
MK-TOL-1103M-2426	24x26	436	345	60	65.70
MK-TOL-1103M-2427	24x27	436	345	60	71.40
MK-TOL-1103M-2528	25x28	488	355	60	71.40
MK-TOL-1103M-3032	30x32	600	370	60	94.10

MK-TOL-10104M

6 PCS 45° DOUBLE RING WRENCH SET



Contains

MK-1101: 10X12, 12X14, 14X17, 17X19, 19X21, 23X26

ITEM CODE	DESCRIPTION	QTY/CTN	PRICE
MK-TOL-10104M	6 Pcs 45° Double Ring Wrench Set	15	176.40

MK-TOL-10108M

8 PCS 45° DOUBLE RING WRENCH SET



Contains

MK-1101: 8X10, 10X12, 11X13, 12X14, 14X17, 17X19, 21X23, 22X24

ITEM CODE	DESCRIPTION	QTY/CTN	PRICE
MK-TOL-10108M	8 Pcs 45° Double Ring Wrench Set	10	135.20

MK-TOL-1105M (Wholly mirror finished handle) FLARE NUT WRENCH

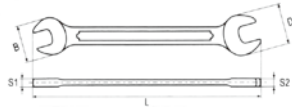

- Chrome vanadium steel with proper heat treatment for extra durability and strength
- Chrome plated finish for extra rust resistance
- Feature with five points of contact for a more secure grip on soft fasteners like brass fittings.
- Ideal to use with fasteners on tubing

ITEM CODE	Size (mm)	W (g)	L (mm)	CTN	Price
MK-TOL-1105M-0809	8x9	46	143	300	23.80
MK-TOL-1105M-0810	8x10	46	143	300	23.80
MK-TOL-1105M-0910	9x10	58	152	200	23.80
MK-TOL-1105M-0911	9x11	58	152	200	23.80
MK-TOL-1105M-1011	10x11	58	152	200	27.30
MK-TOL-1105M-1012	10x12	58	152	200	27.30
MK-TOL-1105M-1213	12x13	80	156	200	27.50
MK-TOL-1105M-1214	12x14	117	178	150	27.50
MK-TOL-1105M-1417	14x17	166	196	100	44.00
MK-TOL-1105M-1719	17x19	166	196	90	44.00

MK-TOL-1151M (German type DIN3110) DOUBLE OPEN END WRENCH



- Chrome vanadium steel with proper heat treatment for extra durability and strength
- Chrome plated finish for extra rust resistance
- 15° open ended head slanted design allowed quick operation

ITEM CODE	Size (mm)	W (g)	L (mm)	CTN	Price
MK-TOL-1151M-0607	6x7	21	123	640	12.20
MK-TOL-1151M-0809	8x9	36	140	400	13.80
MK-TOL-1151M-0810	8x10	36	140	400	13.80
MK-TOL-1151M-1011	10x11	57	156	320	15.00
MK-TOL-1151M-1012	10x12	57	156	320	16.30
MK-TOL-1151M-1213	12x13	73	172	240	16.30
MK-TOL-1151M-1214	12x14	77	180	240	18.90
MK-TOL-1151M-1415	14x15	93	190	150	20.10
MK-TOL-1151M-1417	14x17	93	190	150	22.70
MK-TOL-1151M-1617	16x17	128	221	150	22.70
MK-TOL-1151M-1719	17x19	162	221	100	27.50
MK-TOL-1151M-1819	18x19	162	237	100	27.50
MK-TOL-1151M-1921	19x21	200	237	80	33.40
MK-TOL-1151M-2022	20x22	200	237	80	37.50
MK-TOL-1151M-2123	21x23	200	237	80	37.50
MK-TOL-1151M-2427	24x27	257	263	60	41.40
MK-TOL-1151M-2528	25x28	303	263	60	51.00
MK-TOL-1151M-3032	30x32	336	279	45	63.30

MK-TOL-11104M 8 PCS FLARE NUT WRENCH SET



Contains

MK-1105: 8X9, 8X10, 10X11, 10X12, 12X13, 12X14, 14X17, 17X19

ITEM CODE	DESCRIPTION	QTY/CTN	PRICE
MK-TOL-11104M	8 Pcs Flare Nut Wrench Set	10	226.60

MK-TOL-11105M 6 PCS FLARE NUT WRENCH SET



Contains

MK-1105: 8X9, 10X11, 10X12, 12X13, 12X14, 14X17

ITEM CODE	DESCRIPTION	QTY/CTN	PRICE
MK-TOL-11105M	6 Pcs Flare Nut Wrench Set	15	164.30

MK-TOL-11106M 6 PCS DOUBLE OPEN END WRENCH SET



Contains

MK-1151: 8X9, 10X11, 12X13, 14X15, 16X17, 18X19

ITEM CODE	DESCRIPTION	QTY/CTN	PRICE
MK-TOL-11106M	6 Pcs Double Open End Wrench Set	10	103.20

MK-TOL-11108M 8 PCS DOUBLE OPEN END WRENCH SET



Contains

MK-1151: 6X7, 8X9, 10X11, 12X13, 14X15, 16X17, 18X19, 19X21

ITEM CODE	DESCRIPTION	QTY/CTN	PRICE
MK-TOL-11108M	8 Pcs Double Open End Wrench Set	10	147.40

MK-TOL-16108M

8 PCS COMBINATION WRENCH SET



Contains

MK-1161: 6, 8, 10, 12, 14, 17, 19, 22 mm

ITEM CODE	DESCRIPTION	QTY/CTN	PRICE
MK-TOL-16108M	8 Pcs Combination Wrench Set	15	138.00

MK-TOL-16109M

8 PCS COMBINATION WRENCH SET



Contains

MK-1161: 6, 8, 10, 12, 14, 17, 19, 21mm

ITEM CODE	DESCRIPTION	QTY/CTN	PRICE
MK-TOL-16109M	8 Pcs Combination Wrench Set	15	145.00

MK-TOL-16110M

8 PCS COMBINATION WRENCH SET



Contains

MK-1161: 8, 10, 11, 13, 14, 17, 19, 22 mm

ITEM CODE	DESCRIPTION	QTY/CTN	PRICE
MK-TOL-16110M	8 Pcs Combination Wrench Set	15	128.00

MK-TOL-16196M

6 PCS COMBINATION WRENCH SET



Contains

MK-1161: 8, 10, 12, 14, 17, 19 mm

ITEM CODE	DESCRIPTION	QTY/CTN	PRICE
MK-TOL-16196M	6 Pcs Combination Wrench Set	15	92.30

MK-TOL-16112M

14 PCS COMBINATION WRENCH SET



Contains

MK-1161: 6, 8, 10, 12, 13, 14, 16, 17, 19, 22, 24, 27, 30, 32 mm

ITEM CODE	DESCRIPTION	QTY/CTN	PRICE
MK-TOL-16112M	14 Pcs Combination Wrench Set	10	398.00

MK-TOL-16115M

14 PCS COMBINATION WRENCH SET



Contains

MK-1161: 8, 9, 10, 11, 12, 13, 14, 15, 16, 17, 19, 21, 22, 24 mm

ITEM CODE	DESCRIPTION	QTY/CTN	PRICE
MK-TOL-16115M	14 Pcs Combination Wrench Set	8	263.00

MK-TOL-16126M 26 PCS COMBINATION WRENCH SET



MK-TOL-16115A 14 PCS COMBINATION WRENCH SET



Contains			
MK-1161: 6, 8, 9, 10, 11, 12, 13, 14, 15, 16, 17, 18, 19, 20, 21, 22, 23, 24, 25, 26, 27, 28, 29, 30, 31, 32 mm			

ITEM CODE	DESCRIPTION	QTY/CTN	PRICE
MK-TOL-16126M	26 Pcs Combination Wrench Set	3	787.50

Contains			
MK-1161A: 3/8", 7/16", 1/2", 9/16", 5/8", 11/16", 3/4", 13/16", 7/8", 15/16", 1", 1-1/16", 1-1/8", 1-1/4"			

ITEM CODE	DESCRIPTION	QTY/CTN	PRICE
MK-TOL-16115A	14 Pcs Combination Wrench Set	10	440.50

MK-TOL-16199M 14 PCS SPLINE COMBINATION WRENCH SET



- Chrome vanadium steel with proper heat treatment for extra durability and strength
- Chrome plated finish for extra rust resistance
- Ideal for tightening and removing of spline, 4 point, 6 point, 12 point, star and even 50% rounded off fasteners
- Perfect for automotive workshop

Contains			
MK-1169: 8, 9, 10, 11, 12, 13, 14, 15, 16, 17, 19, 21, 22, 24 mm			

ITEM CODE	DESCRIPTION	QTY/CTN	PRICE
MK-TOL-16199M	14 Pcs Spline Combination Wrench Set	10	330.00

MK-TOL-1181M DOUBLE END SWIVED HEAD SPANNER

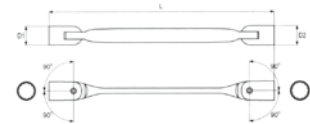

- Chrome vanadium steel with proper heat treatment for extra durability and strength
- Chrome plated finish for extra rust resistance
- Flexible head is ideal for awkward applications

ITEM CODE	Size (mm)	L (mm)	W (g)	QTY/CTN	PRICE
MK-TOL-1181M-0607	6x7	185	72	240	29.80
MK-TOL-1181M-0809	8x9	185	78	240	29.80
MK-TOL-1181M-0810	8x10	185	90	240	29.80
MK-TOL-1181M-1011	10x11	200	115	150	33.80
MK-TOL-1181M-1012	10x12	205	125	150	33.80
MK-TOL-1181M-1213	12x13	220	155	120	37.80
MK-TOL-1181M-1214	12x14	225	170	120	37.80
MK-TOL-1181M-1415	14x15	242	235	100	40.10
MK-TOL-1181M-1417	14x17	244	245	100	42.60
MK-TOL-1181M-1617	16x17	254	330	60	46.20
MK-TOL-1181M-1719	17x19	260	330	60	46.80
MK-TOL-1181M-1819	18x19	275	410	60	53.60
MK-TOL-1181M-2022	20x22	305	595	24	103.20
MK-TOL-1181M-2123	21x23	305	640	24	103.20

MK-TOL-1182M STAR WRENCH



- Chrome vanadium steel with proper heat treatment for extra durability and strength
- Chrome plated finish for extra rust resistance
- For tightening and loosening E-Torx fastener

ITEM CODE	Size	L (mm)	W (g)	QTY/CTN	PRICE
MK-TOL-1182M-0608	E6xE8	112	14	240	31.10
MK-TOL-1182M-0711	E7xE11	125	30	240	31.10
MK-TOL-1182M-1012	E10xE12	140	30	240	31.10
MK-TOL-1182M-1418	E14xE18	180	70	240	31.10
MK-TOL-1182M-1622	E16xE22	200	124	240	32.80
MK-TOL-1182M-2024	E20xE24	224	144	240	37.00

MK-TOL-1184M NON-SLIP FUNCTION OPEN-END*



- Chrome vanadium steel with proper heat treatment for extra durability and strength
- Chrome plated finish for extra rust resistance
- Long handle with thin wall construction
- Non Slip function in box end and open end to protect normal fastener.
- Ideal in removing and tightening 70% rounded off fastener.

ITEM CODE	Size (mm)	L (mm)	W (g)	QTY/CTN	PRICE
MK-TOL-1184M-08	8	125	27	60	41.90
MK-TOL-1184M-10	10	145	36	60	52.90
MK-TOL-1184M-12	12	165	55	60	55.90
MK-TOL-1184M-14	14	185	82	60	66.70
MK-TOL-1184M-17	17	215	130	60	80.10
MK-TOL-1184M-19	19	235	159	60	84.30

MK-TOL-1189 M 45 DEG. OFFSET GERMAN PANEL DOUBLE RING WRENCHES (6-POINT)

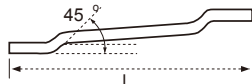

- Chrome vanadium steel with proper heat treatment for extra durability and strength
- Chrome plated finish for extra rust resistance
- 45° oblique design allowed greater access up to 40° narrow space

ITEM CODE	Size (mm)	QTY/CTN	PRICE
MK-TOL-1189M-1723	17x23mm	60	24.20
MK-TOL-1189M-1923	19x23mm	60	29.30

MK-TOL-1183M END SWIVED HEAD SPANNER

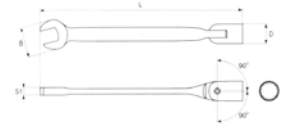

- Chrome vanadium steel with proper heat treatment for extra durability and strength
- Chrome plated finish for extra rust resistance
- Flexible head is ideal for awkward applications

ITEM CODE	Size (mm)	L (mm)	W (g)	QTY/CTN	PRICE
MK-TOL-1183M-08	8	170	65	240	28.30
MK-TOL-1183M-09	9	170	65	240	28.30
MK-TOL-1183M-10	10	180	75	200	28.30
MK-TOL-1183M-11	11	190	105	216	29.40
MK-TOL-1183M-12	12	195	114	216	30.60
MK-TOL-1183M-13	13	210	140	144	32.30
MK-TOL-1183M-14	14	230	186	120	39.60
MK-TOL-1183M-15	15	230	195	120	40.60
MK-TOL-1183M-16	16	235	234	96	46.90
MK-TOL-1183M-17	17	235	234	96	46.90
MK-TOL-1183M-18	18	255	307	72	53.30
MK-TOL-1183M-19	19	255	307	72	53.30

MK-TOL-1185M NIPPLE WRENCH*

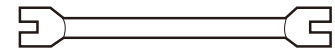

- Chrome vanadium steel with proper heat treatment for extra durability and strength
- Chrome plated finish for extra rust resistance
- Ideal for bicycle and motorcycle repair

ITEM CODE	Size (mm)	L (mm)	W (g)	QTY/CTN	PRICE
MK-TOL-1185M-1011	10 x 11	135	58	360	20.00

MK-TOL-11183M 6 PCS COMEN BOX SOCKET SET



Contains			
MK-1183: 8, 10, 12, 13, 14, 17 mm			
ITEM CODE	DESCRIPTION	QTY/CTN	PRICE
MK-TOL-11183M	6 Pcs Comen Box Socket Set	10	194.40

MK-TOL-1195M COMBINATION RATCHET WRENCH



- Chrome vanadium steel with proper heat treatment for extra durability and strength
- Phosphatised finish for extra rust resistance
- Extra strong design for cars and light truck wheel nuts and bolts

ITEM CODE	Size (mm)	L (mm)	W (g)	QTY/CTN	PRICE
MK-TOL-1195M-08	8 X 8	140	33	50	29.40
MK-TOL-1195M-10	10 X 10	160	51	50	34.60
MK-TOL-1195M-12	12 X 12	170	74	50	39.80
MK-TOL-1195M-14	14 X 14	190	100	50	43.30
MK-TOL-1195M-17	17 X 17	225	172	50	53.70
MK-TOL-1195M-19	19 X 19	248	213	50	58.90

MK-TOL-16188M 14 PCS RATCHET WRENCH SET



72 teeth, CR-V 6140, Full polish (mirror chrome)

- Chrome vanadium steel with proper heat treatment for extra durability and strength
- Chrome plated finish for extra rust resistance
- Features with ultra-smooth 72 teeth ratchet action allowing ratcheting use in restricted area (5°)

Contains

MK-1195: 8, 9, 10, 11, 12, 13, 14, 15, 16, 17, 18, 19, 21, 24 mm

ITEM CODE	DESCRIPTION	QTY/CTN	PRICE
MK-TOL-16188M	14 Pcs Ratchet Wrench Set	6	676.90

MK-TOL-1186M TYRE LEVER

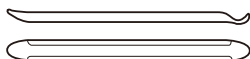

- Chrome vanadium steel with proper heat treatment for extra durability and strength
- Phosphatised finish for extra rust resistance

ITEM CODE	L (mm)	A (mm)	B (mm)	W (g)	QTY/CTN	PRICE
MK-TOL-1186M-21	530	27	15	600	20	83.90

MK-TOL-1187M TYRE LEVER (PRY BAR TYPE)



- Chrome vanadium steel with proper heat treatment for extra durability and strength
- Phosphatised finish for extra rust resistance
- Different ends for various prying applications

ITEM CODE	Size (mm)	L (mm)	W (g)	QTY/CTN	PRICE
MK-TOL-1187M-24	24	600mm	1650	10	180.20

MK-TOL-11195M 6 PCS RATCHET WRENCH SET



Contains

MK-1195: 8, 10, 12, 14, 17, 19 mm

ITEM CODE	DESCRIPTION	QTY/CTN	PRICE
MK-TOL-11195M	6 Pcs Ratchet Wrench Set	10	233.70

MK-TOL-11117 7 PCS FLEXIBLE RATCHET WRENCH SET



- Chrome vanadium 6140 steel with proper heat treatment for extra durability and strength
- Chrome plated finish for extra rust resistance
- Features with ultra-smooth 72 teeth ratchet action allowing ratcheting use in restricted area (5°)

Contains

8, 10, 12, 13, 14, 17, 19 mm

ITEM CODE	DESCRIPTION	QTY/CTN	PRICE
MK-TOL-11117M	7 Pcs Flexible Ratchet Wrench Set	10	436.20

MK-TOL-1188M FOUR-WAY HEXAGON WHEEL NUT WRENCH

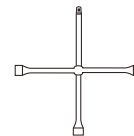

- Chrome vanadium steel with proper heat treatment for extra durability and strength
- Phosphatised finish for extra rust resistance
- Extra strong design for cars and light truck wheel nuts and bolts

ITEM CODE	Size (mm)	L (mm)	W (g)	QTY/CTN	PRICE
MK-TOL-1188M	17x19x21x1/2"	400mm	1500	12	80.00

MK-TOL-1191M Y BEND SOCKET WRENCH*



Professional T-Handle Deep Socket Wrench

- Chrome vanadium steel.
- Hardened & Tempered

Size: 8x10x12 mm

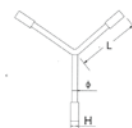

ITEM CODE	DESCRIPTION	QTY/CTN	PRICE
MK-TOL-1191M	Y Bend Sockets Wrench	100	35.50



HAND SOCKETS AND ACCESSORIES

Hand Sockets Safety Uses

Sensible precautions !

- Secure your balance. Pull the tool towards you rather than push it.
- Use only recommended extensions and do not overload.
- Ratchets are designed to speed up rotation. For loosening very tight fasteners, select a sliding tee. Check that ratchet mechanisms engage fully..
- Ratchet maintenance is simple. Cleaning and lubrication is normally sufficient.
- Select 6-point sockets if fasteners are worn or hardened.
- Check condition of both tool and fastener before use. Do not use tools showing signs of breakage or excessive wear.
- Do not use hand sockets with impact or power-driven tools. Serious injury is possible.
- Use safety goggles. Serious eye injury is possible.
- Do not hammer on sockets or drive tools.
- Do not use extenders or cheater bars.
- Wear gloves and eye protection.
- Make sure that you are well balanced, and pull the tool towards you rather than pushing it.
- Use only recommended extension and do not overload.
- Ratchets are specially designed to speed up rotation. For loosening very tight fasteners, it is preferable to select a sliding tee. Check that ratchet mechanism engagefully.
- Ratchets maintenances is simple and normally requires only cleaning and lubrication to ensure optimum performance.
- Select 6 point socket if fasteners are worn or hardened.
- Check condition of both tool and fastener before use. Do not use tools showing sign of excessive wear or breakage.
- Disconnect electricity when working on electrical parts.
- Prevent slipping. Keep tools clean.



- Only use impact sockets when locked



- Don't exceed tool capacity or use oversize extensions.

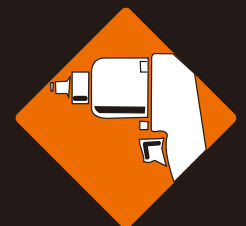



HAND SOCKETS UNIQUENESS



High grade of chrome vanadium steel with proper heat treatment for extra durability and strength



Satin chrome plated finish for extra rust resistance



Knurled ring design for extra grip with oily finger



Thin wall design allow users operate in tight area



MK-TOL-3120N RATCHET HANDLE* MK-TOL-3120NQ QUICK RELEASE RATCHET HANDLE*

3/8"



L=175mm/7" =300g



- Chrome vanadium steel with proper heat treatment for extra durability and strength
- Chrome plated finish for extra rust resistance
- Features with ultra-smooth 45 teeth ratchet action allowing ratcheting use in restricted area (8°)
- Quick release push button provide extra safety and efficient operation.

ITEM CODE	DESCRIPTION	QTY/CTN	PRICE
MK-TOL-3120N	Ratchet Handle	30	58.00
MK-TOL-3120NQ	Quick Release Ratchet Handle	30	73.90

MK-TOL-3200 UNIVERSAL JOINT

3/8"

L=52mm

=80g

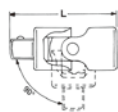

- Chrome vanadium steel with proper heat treatment for extra durability and strength
- Chrome plated finish for extra rust resistance
- Spring action for presetting the socket in the desired working angle

ITEM CODE	DESCRIPTION	QTY/CTN	PRICE
MK-TOL-3200	Universal Joint	120	25.00

MK-TOL-3300M 6-POINT DEEP SOCKET



3/8"

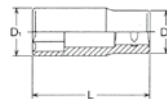

- High grade of chrome vanadium steel with proper heat treatment for extra durability and strength
- Satin chrome plated finish for extra rust resistance
- Knurled ring design for extra grip with oily finger
- Thin wall design allow users operate in tight area

Item Code	Size (mm)	D1 (mm)	D2 (mm)	L (mm)	g	Qty/Ctn	Price
MK-TOL-3300M-07	7	10.6	17	63	52	200	12.00
MK-TOL-3300M-08	8	11.8	17	63	52	200	12.00
MK-TOL-3300M-09	9	13.2	17	63	56	200	12.00
MK-TOL-3300M-10	10	14.5	17	63	60	200	12.00
MK-TOL-3300M-11	11	15.7	17	63	68	200	12.00
MK-TOL-3300M-12	12	17	16.4	63	68	200	12.00
MK-TOL-3300M-13	13	18	17	63	64	160	12.30
MK-TOL-3300M-14	14	19.6	17	63	72	160	13.00
MK-TOL-3300M-15	15	20.9	18	63	88	160	13.30
MK-TOL-3300M-16	16	22	18	63	88	120	13.30
MK-TOL-3300M-17	17	23.4	18	63	112	120	13.90
MK-TOL-3300M-18	18	24.6	22	63	126	120	13.90
MK-TOL-3300M-19	19	26	24	63	124	80	14.30
MK-TOL-3300M-20	20	27.1	26	63	125	80	17.20
MK-TOL-3300M-21	21	28	26	63	126	80	17.20
MK-TOL-3300M-22	22	30	27	63	128	80	18.00



MK-TOL-3302M 12-POINT DEEP SOCKET



3/8"

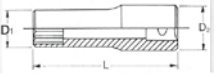

- High grade of chrome vanadium steel with proper heat treatment for extra durability and strength
- Satin chrome plated finish for extra rust resistance
- Knurled ring design for extra grip with oily finger
- Thin wall design allow users operate in tight area

Item Code	Size (mm)	D1 (mm)	D2 (mm)	L (mm)	Weight (g)	Qty/Ctn	Price
MK-TOL-3302M-07	7	10.6	17	63	52	200	12.00
MK-TOL-3302M-08	8	11.8	17	63	52	200	12.00
MK-TOL-3302M-09	9	13.2	17	63	56	200	12.00
MK-TOL-3302M-10	10	14.5	17	63	60	200	12.00
MK-TOL-3302M-11	11	15.7	17	63	68	200	12.00
MK-TOL-3302M-12	12	17	16.4	63	68	200	12.00
MK-TOL-3302M-13	13	18	17	63	64	160	12.30
MK-TOL-3302M-14	14	19.6	17	63	72	160	13.00
MK-TOL-3302M-15	15	20.9	17	63	88	160	13.30
MK-TOL-3302M-16	16	22	18	63	88	120	13.30
MK-TOL-3302M-17	17	23.4	18	63	112	120	13.90
MK-TOL-3302M-18	18	24.6	20	63	126	120	13.90
MK-TOL-3302M-19	19	26	20	63	124	80	14.30
MK-TOL-3302M-20	20	27.1	20	63	125	80	17.20
MK-TOL-3302M-21	21	28	20	63	126	80	18.00
MK-TOL-3302M-22	22	30	20	63	128	80	19.10

MK-TOL-3400M 6-POINT SOCKET

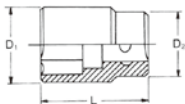

- High grade of chrome vanadium steel with proper heat treatment for extra durability and strength
- Satin chrome plated finish for extra rust resistance
- Knurled ring design for extra grip with oily finger
- Thin wall design allow users operate in tight area

Item Code	Size (mm)	D1 (mm)	D2 (mm)	L (mm)	Weight (g)	Qty/Ctn	Price
MK-TOL-3400M-07	7	10.6	17	28	24	400	7.20
MK-TOL-3400M-08	8	11.8	17	28	25	400	7.20
MK-TOL-3400M-09	9	13.2	17	28	25	400	7.20
MK-TOL-3400M-10	10	14.5	17	28	27	400	7.20
MK-TOL-3400M-11	11	15.7	17	28	28	400	7.20
MK-TOL-3400M-12	12	17	16.4	28	28	400	7.20
MK-TOL-3400M-13	13	18	17	28	31	300	7.30
MK-TOL-3400M-14	14	20	17	28	34	300	7.30
MK-TOL-3400M-15	15	20.9	18	28	47	300	8.00
MK-TOL-3400M-16	16	22	18	28	45	200	8.00
MK-TOL-3400M-17	17	24	18	30	53	200	8.10
MK-TOL-3400M-18	18	26	18	30	58	200	8.40
MK-TOL-3400M-19	19	26	20	30	64	200	9.20
MK-TOL-3400M-20	20	28	20	30	73	200	10.50
MK-TOL-3400M-21	21	28	20	30	82	200	10.50
MK-TOL-3400M-22	22	30	20	32	87	200	11.60

MK-TOL-3305M 6-POINT SPARK PLUG SOCKET

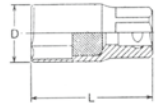

- Chrome vanadium steel with proper heat treatment for extra durability and strength
- Chrome plated finish for extra rust resistance
- Rubber retainer to grip the spark plug

Item Code	Size (mm)	D (mm)	L (mm)	Weight (g)	Qty/Ctn	Price
MK-TOL-3305M-16	16	22	63	69.4	200	18.40
MK-TOL-3305M-20.8	20.8	28	65	99	200	18.40

MK-TOL-3335M 6-POINT MAGNETIC SPARK PLUG SOCKET

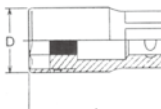

- Chrome vanadium steel with proper heat treatment for extra durability and strength
- Chrome plated finish for extra rust resistance

Item Code	Size (mm)	D (mm)	L (mm)	Weight (g)	Qty/Ctn	Price
MK-TOL-3335M-16	16	22	63	108	200	32.30
MK-TOL-3335M-20.8	20.8	28	63	168	200	34.30

MK-TOL-3402M 12-POINT SOCKET

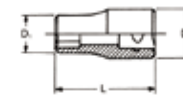

- High grade of chrome vanadium steel with proper heat treatment for extra durability and strength
- Satin chrome plated finish for extra rust resistance
- Knurled ring design for extra grip with oily finger
- Thin wall design allow users operate in tight area

Item Code	Size (mm)	D1 (mm)	D2 (mm)	L (mm)	Weight (g)	Qty/Ctn	Price
MK-TOL-3402M-06	6	9.3	17	28	25	400	7.20
MK-TOL-3402M-07	7	10.6	17	28	24	400	7.20
MK-TOL-3402M-08	8	11.8	17	28	25	400	7.20
MK-TOL-3402M-09	9	13.2	17	28	25	400	7.20
MK-TOL-3402M-10	10	14.5	17	28	27	400	7.20
MK-TOL-3402M-11	11	15.7	17	28	28	400	7.20
MK-TOL-3402M-12	12	17	16.4	28	28	400	7.20
MK-TOL-3402M-13	13	18	17	28	31	300	7.30
MK-TOL-3402M-14	14	20	17	28	34	300	7.30
MK-TOL-3402M-15	15	20.9	18	28	47	300	8.00
MK-TOL-3402M-16	16	22	18	28	45	200	8.00
MK-TOL-3402M-17	17	24	18	30	53	200	8.10
MK-TOL-3402M-18	18	26	18	30	58	200	8.40
MK-TOL-3402M-19	19	26	20	30	64	200	9.20
MK-TOL-3402M-20	20	28	20	30	73	200	10.50
MK-TOL-3402M-21	21	28	20	30	82	200	10.50
MK-TOL-3402M-22	22	30	20	32	87	200	11.60
MK-TOL-3402M-23	23	32	24	32	80	200	11.60
MK-TOL-3402M-24	24	32	24	32	80	200	11.60



MK-TOL-3700N FLEXIBLE HANDLE

3/8"



L=250mm/10" =325g



- Chrome vanadium steel with proper heat treatment for extra durability and strength
- Chrome plated finish for extra rust resistance

ITEM CODE	DESCRIPTION	QTY/CTN	PRICE
MK-TOL-3700N	Flexible Handle	72	35.90

MK-TOL-3800 EXTENSION BAR

3/8"



- Chrome vanadium steel with proper heat treatment for extra durability and strength
- Chrome plated finish for extra rust resistance

ITEM CODE	MM	INCH		QTY/CTN	PRICE
MK-TOL-3800-075	75	3"	75g	200	8.80
MK-TOL-3800-125	125	5"	125g	120	14.20
MK-TOL-3800-150	150	6"	150g	120	14.20
MK-TOL-3800-225	225	9"	g	80	22.80

MK-TOL-4024M STAR BIT SOCKET

1/2"

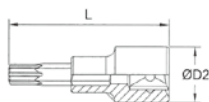

- High grade of chrome vanadium steel with proper heat treatment for extra durability and strength
- Satin chrome plated finish for extra rust resistance
- Knurled ring design for extra grip with oily finger
- For tightening and removing of Star screw with 1/2" hand ratchet

Item Code	Size (mm)	D2	Length (mm)		Qty/Ctn	Price
MK-TOL-4024M-T20	T20	22	55	70	144	21.20
MK-TOL-4024M-T25	T25	22	55	70	144	21.20
MK-TOL-4024M-T27	T27	22	55	70	144	21.20
MK-TOL-4024M-T30	T30	22	55	73	144	21.20
MK-TOL-4024M-T40	T40	22	55	73	144	21.20
MK-TOL-4024M-T45	T45	22	55	78	144	21.20
MK-TOL-4024M-T47	T47	22	55	78	144	21.20
MK-TOL-4024M-T50	T50	22	55	80	144	21.20
MK-TOL-4024M-T55	T55	22	55	83	144	27.40
MK-TOL-4024M-T60	T60	22	55	113	144	28.40
MK-TOL-4024M-T70	T70	22	55	115	144	34.80
MK-TOL-4024M-T80	T80	22	70	115	120	53.00

MK-TOL-3770 SLIDING "T" HANDLE

3/8"



L=200mm/8" =182g



- Chrome vanadium steel with proper heat treatment for extra durability and strength
- Chrome plated finish for extra rust resistance

ITEM CODE	DESCRIPTION	QTY/CTN	PRICE
MK-TOL-3770	Sliding "T" Handle	80	21.60

MK-TOL-4022M PHILLIPS BIT SOCKET

1/2"



ITEM CODE	Size No	D2	Length (mm)		Qty/Ctn	Price
MK-TOL-4022M-02	2	22	55	77	192	21.20
MK-TOL-4022M-03	3	22	55	77	192	21.20
MK-TOL-4022M-04	4	22	55	77	192	21.20

MK-TOL-4026M HEX BIT SOCKET

1/2"

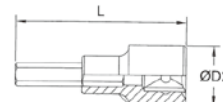

- High grade of chrome vanadium steel with proper heat treatment for extra durability and strength
- Satin chrome plated finish for extra rust resistance
- Knurled ring design for extra grip with oily finger
- For tightening and removing of Hex screw with 1/2" hand ratchet

Item Code	Size (mm)	Size (inch)	D2	Length (mm)		Qty/Ctn	Price
MK-TOL-4026M-04	4	5/32"	22	83	83	144	14.00
MK-TOL-4026M-05	5	3/16"	22	83	83	144	14.00
MK-TOL-4026M-06	6	1/4"	22	83	83	144	14.00
MK-TOL-4026M-07	7	9/32"	22	83	83	144	14.00
MK-TOL-4026M-08	8	5/16"	22	83	83	144	14.00
MK-TOL-4026M-09	9	11/32"	22	83	83	144	14.00
MK-TOL-4026M-10	10	3/8"	22	83	83	144	14.00
MK-TOL-4026M-12	12	1/2"	22	92	92	144	17.60
MK-TOL-4026M-14	14	9/16"	24	92	92	144	24.90
MK-TOL-4026M-17	17	11/16"	24	102	102	96	25.40
MK-TOL-4026M-19	19	3/4"	24	102	102	96	59.20



MK-4028M SPLINE BIT SOCKET

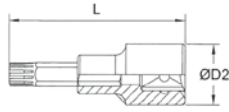

ITEM CODE	Size (mm)	Length (mm)	(g)	Qty/Ctn	Price
MK-TOL-4028M-05	M5	55	65	144	21.20
MK-TOL-4028M-06	M6	55	70	144	21.20
MK-TOL-4028M-08	M8	55	70	144	21.20
MK-TOL-4028M-10	M10	55	92	144	21.20
MK-TOL-4028M-12	M12	55	100	144	24.20
MK-TOL-4028M-14	M14	55	120	144	34.80
MK-TOL-4028M-16	M16	55	142	144	43.80

MK-TOL-4160NQ QUICK RELEASE RATCHET HANDLE



1/2"

L=255mm
 =500g

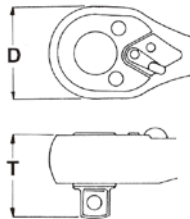

Curved handle design allowed operate in tight area

- Chrome vanadium steel with proper heat treatment for extra durability and strength
- Chrome plated finish for extra rust resistance
- Ergonomic rubber grip handle with reversible ratchet wrench provide comfortable uses
- Features with ultra-smooth 72 teeth ratchet action allowing ratcheting use in restricted area (5°)
- Quick release push button provide extra safety and efficient operation

ITEM CODE	D(mm)	T(mm)	TEETH	QTY/CTN	PRICE
MK-TOL-4160NQ	26	21	72	40	75.00

MK-TOL-4120NQ QUICK RELEASE RATCHET HANDLE

1/2"



L=245mm/10" =475g

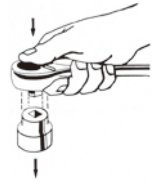

- Chrome vanadium steel with proper heat treatment for extra durability and strength
- Chrome plated finish for extra rust resistance
- Features with ultra-smooth 45 teeth ratchet action allowing ratcheting use in restricted area (8°)
- Quick release push button provide extra safety and efficient operation.

ITEM CODE	DESCRIPTION	QTY/CTN	PRICE
MK-TOL-4100N*	Ratchet Handle		62.10
MK-TOL-4120NQ	Quick Release Ratchet Handle	40	68.00

MK-TOL-4180NQ QUICK RELEASE ROTATING RATCHET HANDLE

1/2"



L=280mm
 =660g

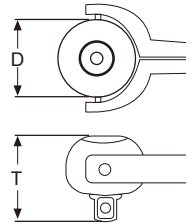

180 degree rotary allowed operation in various angle

- Chrome vanadium steel with proper heat treatment for extra durability and strength
- Chrome plated finish for extra rust resistance
- Ergonomic rubber grip handle with reversible ratchet wrench provide comfortable uses
- Features with ultra-smooth 72 teeth ratchet action allowing ratcheting use in restricted area (5°)
- Quick release push button provide extra safety and efficient operation
- 180 degree rotary allowed operation in various angle with two way switch

ITEM CODE	D(mm)	T(mm)	TEETH	QTY/CTN	PRICE
MK-TOL-4180NQ	26	21	72	30	160.00



MK-TOL-4190NQ TELESCOPIC RATCHET HANDLE



L=305mm - 445mm =917g

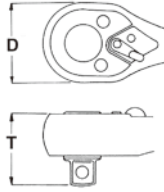

Easy extension design



6 length extension adjustment

- Chrome vanadium steel with proper heat treatment for extra durability and strength
- Chrome plated finish for extra rust resistance
- Ergonomic rubber grip handle with reversible ratchet wrench provide comfortable uses
- Features with ultra-smooth 72 teeth ratchet action allowing ratcheting use in restricted area (5°)
- Quick release push button provide extra safety and efficient operation
- Feature with 6 length extension adjustment

ITEM CODE	D(mm)	T(mm)	TEETH	QTY/CTN	PRICE
MK-TOL-4190NQ	40	45	72	20	138.00

MK-TOL-4200 UNIVERSAL JOINT

1/2"



L=75mm

=163g

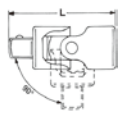

- Chrome vanadium steel with proper heat treatment for extra durability and strength
- Chrome plated finish for extra rust resistance
- Spring action for presetting the socket in the desired working angle

ITEM CODE	DESCRIPTION	QTY/CTN	PRICE
MK-TOL-4200-70	Universal Joint	120	31.30

MK-TOL-4335M 6-POINT MAGNETIC SPARK PLUG SOCKET



- Chrome vanadium steel with proper heat treatment for extra durability and strength
- Chrome plated finish for extra rust resistance
- Hexagon opening magnetic system to retain the spark plug

Item Code	Size (mm)	Length (mm)	(g)	Qty/Ctn	Price
MK-TOL-4335M-16	16	65	115	160	33.10
MK-TOL-4335M-21	21	65	165	160	34.30

MK-TOL-4250NQ QUICK RELEASE RATCHET HANDLE



L=255mm

=470g

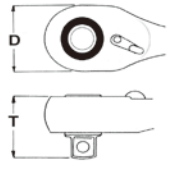

Ultra head design for hard access places

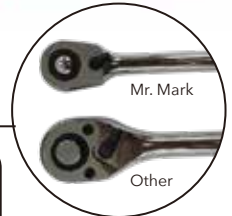
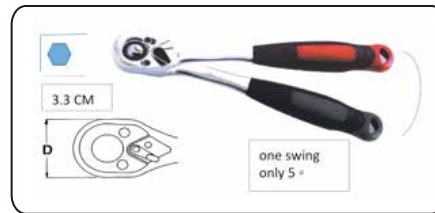

- Chrome vanadium steel with proper heat treatment for extra durability and strength
- Chrome plated finish for extra rust resistance
- Ergonomic rubber grip handle with reversible ratchet wrench provide comfortable uses
- Features with ultra-smooth 72 teeth ratchet action allowing ratcheting use in restricted area (5°)
- Quick release push button provide extra safety and efficient operation
- Compact construction for hard access places

ITEM CODE	D(mm)	T(mm)	TEETH	QTY/CTN	PRICE
MK-TOL-4250NQ	26	21	72	40	102.90

MK-TOL-4300M 6-POINT DEEP SOCKET



1/2"

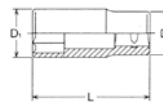

- High grade of chrome vanadium steel with proper heat treatment for extra durability and strength
- Satin chrome plated finish for extra rust resistance
- Knurled ring design for extra grip with oily finger
- Thin wall design allow users operate in tight area

Item Code	Size (mm)	D1 (mm)	D2 (mm)	L (mm)	(g)	Qty/Ctn	Price
MK-TOL-4300M-08	8	12.2	22	77	113	120	15.90
MK-TOL-4300M-09	9	13.5	22	77	114	120	15.90
MK-TOL-4300M-10	10	15	22	77	116	120	15.90
MK-TOL-4300M-11	11	16.3	22	77	118	120	15.90
MK-TOL-4300M-12	12	17.6	22	77	125	120	15.90
MK-TOL-4300M-13	13	18.8	22	77	124	120	15.90
MK-TOL-4300M-14	14	20.4	22	77	127	120	15.90
MK-TOL-4300M-15	15	21	22	77	140	80	15.90
MK-TOL-4300M-16	16	22	20.5	77	139	80	15.90
MK-TOL-4300M-17	17	24	22	77	132	80	16.40
MK-TOL-4300M-18	18	25.4	22	77	136	80	18.90
MK-TOL-4300M-19	19	26	22	77	151	80	18.90
MK-TOL-4300M-20	20	28	22	77	194	80	19.80
MK-TOL-4300M-21	21	28	22	77	163	80	19.80
MK-TOL-4300M-22	22	30	26	77	166	80	21.20
MK-TOL-4300M-23	23	31.6	26	77	208	60	21.70
MK-TOL-4300M-24	24	32	26	77	212	60	21.70
MK-TOL-4300M-25	25	34	26	77	224	60	27.10
MK-TOL-4300M-26	26	35.4	28	77	270	60	27.10
MK-TOL-4300M-27	27	36	28	77	312	60	31.90
MK-TOL-4300M-28	28	38	28	77	309	40	31.90
MK-TOL-4300M-29	29	38	28	77	309	40	32.20
MK-TOL-4300M-30	30	40	28	77	307	40	36.00
MK-TOL-4300M-32	32	42	28	77	334	48	36.00



MK-TOL-4302M 12-POINT DEEP SOCKET

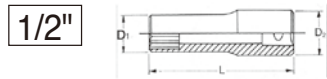

- High grade of chrome vanadium steel with proper
- Satin chrome plated finish for extra rust resistance
- Knurled ring design for extra grip with oily finger
- Thin wall design allow users operate in tight area

Item Code	Size (mm)	D1 (mm)	D2 (mm)	L (mm)	5/8 (g)	Qty/Ctn	Price
MK-TOL-4302M-08	8	12.2	22	77	113	120	15.90
MK-TOL-4302M-09	9	13.5	22	77	114	120	15.90
MK-TOL-4302M-10	10	15	22	77	116	120	15.90
MK-TOL-4302M-11	11	16.3	22	77	118	120	15.90
MK-TOL-4302M-12	12	17.6	22	77	125	120	15.90
MK-TOL-4302M-13	13	18.8	22	77	124	120	15.90
MK-TOL-4302M-14	14	20.4	22	77	127	120	15.90
MK-TOL-4302M-15	15	21	22	77	140	120	15.90
MK-TOL-4302M-16	16	22	20.5	77	139	80	15.90
MK-TOL-4302M-17	17	24	22	77	132	80	16.40
MK-TOL-4302M-18	18	25.4	22	77	136	80	18.90
MK-TOL-4302M-19	19	26	22	77	151	80	18.90
MK-TOL-4302M-20	20	28	22	77	194	80	19.80
MK-TOL-4302M-21	21	28	22	77	163	80	19.80
MK-TOL-4302M-22	22	30	26	77	166	60	21.20
MK-TOL-4302M-23	23	31.6	26	77	208	60	21.70
MK-TOL-4302M-24	24	32	26	77	212	60	21.70
MK-TOL-4302M-25	25	34	26	77	224	60	27.10
MK-TOL-4302M-26	26	35.4	28	77	270	40	27.10
MK-TOL-4302M-27	27	36	28	77	312	40	31.90
MK-TOL-4302M-28	28	38	28	77	309	40	31.90
MK-TOL-4302M-29	29	38	28	77	309	40	32.20
MK-TOL-4302M-30	30	40	28	77	307	40	36.00
MK-TOL-4302M-32	32	42	28	77	334	48	36.00

MK-TOL-4400M 6-POINT SOCKET

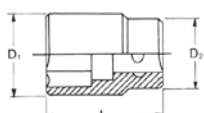

- High grade of chrome vanadium steel with proper heat treatment
- Satin chrome plated finish for extra rust resistance
- Knurled ring design for extra grip with oily finger
- Thin wall design allow users operate in tight area

Item Code	4400M (mm)	D1 (mm)	D2 (mm)	L (mm)	Qty/Ctn	Price	
MK-TOL-4400M-08	8	12.2	22	38	61	200	7.60
MK-TOL-4400M-09	9	13.5	22	38	59	200	7.60
MK-TOL-4400M-10	10	15	22	38	60	200	7.60
MK-TOL-4400M-11	11	16.3	22	38	60	200	7.60
MK-TOL-4400M-12	12	17.6	22	38	61	200	7.60
MK-TOL-4400M-13	13	18.8	22	38	63	200	7.60
MK-TOL-4400M-14	14	20.4	22	38	63	200	7.60
MK-TOL-4400M-15	15	21	22	38	66	180	8.40
MK-TOL-4400M-16	16	22	20.5	38	64	180	9.00
MK-TOL-4400M-17	17	24	22	38	68	180	9.00
MK-TOL-4400M-18	18	25.4	22	38	75	180	10.10
MK-TOL-4400M-19	19	26	22	38	86	180	11.00
MK-TOL-4400M-20	20	28	22	38	95	180	12.30
MK-TOL-4400M-21	21	28	22	38	97	180	13.80
MK-TOL-4400M-22	22	30	26	38	105	150	13.80
MK-TOL-4400M-23	23	31.6	26	38	118	150	14.40
MK-TOL-4400M-24	24	32	26	38	138	150	14.40
MK-TOL-4400M-25	25	34	26	42	141	150	18.50
MK-TOL-4400M-26	26	35.4	28	42	158	100	18.50
MK-TOL-4400M-27	27	36	28	42	161	100	20.30
MK-TOL-4400M-28	28	38	28	43	162	100	20.70
MK-TOL-4400M-29	29	38	28	43	199	100	21.80
MK-TOL-4400M-30	30	40	28	43	214	100	24.30
MK-TOL-4400M-32	32	42	28	44	236	90	26.00

MK-TOL-4402M 12-POINT SOCKET

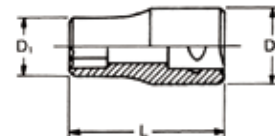

- High grade of chrome vanadium steel with proper heat treatment for extra durability and strength
- Satin chrome plated finish for extra rust resistance
- Knurled ring design for extra grip with oily finger
- Thin wall design allow users operate in tight area

Item Code	Size (mm)	D1 (mm)	D2 (mm)	L (mm)	5/8 (g)	Qty/Ctn	Price
MK-TOL-4402M-08	8	12.2	22	38	61	200	7.60
MK-TOL-4402M-09	9	13.5	22	38	59	200	7.60
MK-TOL-4402M-10	10	15	22	38	60	200	7.60
MK-TOL-4402M-11	11	16.3	22	38	60	200	7.60
MK-TOL-4402M-12	12	17.6	22	38	61	200	7.60
MK-TOL-4402M-13	13	18.8	22	38	63	200	7.60
MK-TOL-4402M-14	14	20.4	22	38	63	200	7.60
MK-TOL-4402M-15	15	21	22	38	66	180	8.40
MK-TOL-4402M-16	16	22	20.5	38	64	180	9.00
MK-TOL-4402M-17	17	24	22	38	68	180	9.00
MK-TOL-4402M-18	18	25.4	22	38	75	180	10.10
MK-TOL-4402M-19	19	26	22	38	86	180	11.00
MK-TOL-4402M-20	20	28	22	38	95	180	12.30
MK-TOL-4402M-21	21	28	22	38	97	180	13.80
MK-TOL-4402M-22	22	30	26	38	105	150	13.80
MK-TOL-4402M-23	23	31.6	26	38	118	150	14.40
MK-TOL-4402M-24	24	32	26	38	138	150	14.40
MK-TOL-4402M-25	25	34	26	42	141	150	18.50
MK-TOL-4402M-26	26	35.4	28	42	158	100	18.50
MK-TOL-4402M-27	27	36	28	42	161	100	20.30
MK-TOL-4402M-28	28	38	28	43	162	100	20.70
MK-TOL-4402M-29	29	38	28	43	199	100	21.80
MK-TOL-4402M-30	30	40	28	43	214	100	24.30
MK-TOL-4402M-32	32	42	28	44	236	90	26.00

MK-TOL-4390M Dr. STUD PULLER SOCKET



- For inserting or extracting stud bolts without damaging the threads.

Item Code	Size (mm)	D1 (mm)	D2 (mm)	L (mm)	5/8 (g)	Qty/Ctn	Price
MK-TOL-4390M-06	6	21	24	60	120	300	48.10
MK-TOL-4390M-08	8	21	24	61	120	300	48.10
MK-TOL-4390M-10	10	21	28	69	180	300	52.00
MK-TOL-4390M-12	12	21	28	69	180	300	52.00



MK-TOL-4610M 10 PCS SOCKET SET



CONTENTS:

9 PCS	1/2" DR. SOCKET	8mm, 9mm, 10mm, 12mm, 13mm, 14mm, 17mm, 19mm, 21mm
1 PC	1/2" L HANDLE	

- Chrome vanadium steel with proper heat treatment for extra durability and strength
- Chrome plated finish for extra rust resistance
- Basic hand socket set for general application

ITEM CODE	DESCRIPTION	QTY/CTN	PRICE
MK-TOL-4610M	10 Pcs Socket Set	12	101.70

MK-TOL-4700N FLEXIBLE HANDLE



4700N-38 L=380mm/15" =680g



- Chrome vanadium steel with proper heat treatment for extra durability and strength
- Chrome plated finish for extra rust resistance

ITEM CODE	DESCRIPTION	QTY/CTN	PRICE
MK-TOL-4700N-38	Flexible Handle	20	74.30

MK-TOL-4804 ADAPTOR



1/2"x 3/8"
L=46mm =66g

MK-TOL-4805 ADAPTOR



1/2"x 3/4"
L=46mm =125g



- Chrome vanadium steel with proper heat treatment for extra durability and strength
- Chrome plated finish for extra rust resistance with ball locking
- Maximum permission torque: 202Nm

ITEM CODE	DESCRIPTION	QTY/CTN	PRICE
MK-TOL-4804-1/2X3/8	Adaptor	200	15.30
MK-TOL-4805	Adaptor	80	23.60

MK-TOL-4770N SLIDING "T" HANDLE



1/2" L=300mm/12" =500g



- Chrome vanadium steel with proper heat treatment for extra durability and strength
- Chrome plated finish for extra rust resistance

ITEM CODE	DESCRIPTION	QTY/CTN	PRICE
MK-TOL-4770N	Sliding "T" Handle	50	26.50

MK-TOL-4777-CHR CHROME L-HANDLE



1/2" L = 260mm, = 445g



- Chrome vanadium steel with proper heat treatment for extra durability and strength
- Chrome plated finish for extra rust resistance

ITEM CODE	DESCRIPTION	QTY/CTN	PRICE
MK-TOL-4777	Chrome L-Handle	40	26.00

MK-TOL-4802 DUAL-DRIVE EXTENSION BAR



- Chrome vanadium steel with proper heat treatment for extra durability and strength
- Chrome plated finish for extra rust resistance
- Giving a working angle of 8° with respect to the socket axis

ITEM CODE	MM	INCH		QTY/CTN	PRICE
MK-TOL-4802-075	75	3"	120g	120	18.00
MK-TOL-4802-125	125	5"	170g	80	22.30
MK-TOL-4802-250	250	10"	320g	50	34.40

MK-TOL-4800 EXTENSION BAR



- Chrome vanadium steel with proper heat treatment for extra durability and strength
- Chrome plated finish for extra rust resistance

ITEM CODE	MM	INCH		QTY/CTN	PRICE
MK-TOL-4800-075	75	3"	130g	120	14.60
MK-TOL-4800-125	125	5"	180g	80	19.00
MK-TOL-4800-250	250	10"	330g	50	31.60



MK-TOL-46107

107 PCS SOCKET WRENCHES SET

1/4" 1/2"    

Suitable for:

- Professional**
Industrial tooling that has enhanced features and benefits demanded by craftsmen and professional users
- Industrial**
Designed for regular use in industrial applications. Manufactured to stringent quality levels and international standards.
- Workshop**
Standard quality tooling for use by tradesmen and generally industrial use.
- Maintenance**
Products designed for general maintenance of machines, workshops, garage and some household applications.
- Renovator**
Designed for Renovator use and light industrial applications.







- High grade chrome vanadium steel with proper heat treatment for extra durability and strength
- Satin chrome plated finish for extra rust resistance
- Supplied with 107pcs hand tools
- Recommended for renovators, automotive workshop and maintenance uses

1/4" DRIVER		
12PCS	SOCKET	4,4.5,5,5.5,6,7,8,9,10,11,12,13MM
2PCS	EXTENSION BAR	2",4'
1PC	RATCHET HANDLE	
1PC	UNIVERSAL JOINT	
1PC	SLIDING T HANDLE	
1PC	COUPLER	
1PC	SPINNER HANDLE	
1PC	FLEXIBLE EXTENSION	150MM
30PCS	BIT SET	(+)0,1,2,3,4,(*)0,1,2,3,4 (T)10,15,20,25,27,30 (-)3,4,4.5,5,5.5,6 (H)1.5,2,2.5,3,4,5,6 QUICK CHUCK
1/2" DRIVER		
20PCS	SOCKET	8,10,12,13,14,15,16,17,18,19,20,21,22,23,24,25,26,27,30,32MMMM
2PCS	EXTENSION BAR	5",10"
1PC	WOBBLE EXTENSION	2"
2PCS	SPARK PLUG SOCKET	16,21MM
1PC	RATCHET HANDLE	
1PC	UNIVERSAL JOINT	
1PC	FLEXIBLE HANDLE	
TOOLS & ACCESSORIES		
1PC	3-WAY ADAPTOR	3/8"F*1/2"M
6PCS	HEX KEY	2.5,3,4,5,6,7MM
1PC	AUTO VOLTAGE TESTER	
1PC	COMBINATION PLIERS	6"
1PC	WATER PUMP PLIERS	10"
1PC	HAMMER	500GM
1PC	COMBINATION WRENCH	6,7,8,9,10,11,12,13,14,15,16,17,19,21MM
4PCS	DOUBLE FLEXIBLE SOCKET WRENCH	10X11,12X13,14X15,17X19MM
CARRYING CASE		

ITEM CODE	DESCRIPTION	QTY/CTN	PRICE
MK-TOL-46107-06P	107 Pcs Socket Wrench Set	2	1,200.00

MK-TOL-46137

137 PCS SOCKET WRENCHES SET

1/4" 3/8" 1/2"    

Suitable for:

- Professional**
Industrial tooling that has enhanced features and benefits demanded by craftsmen and professional users
- Industrial**
Designed for regular use in industrial applications. Manufactured to stringent quality levels and international standards.
- Workshop**
Standard quality tooling for use by tradesmen and generally industrial use.
- Maintenance**
Products designed for general maintenance of machines, workshops, garage and some household applications.



- High grade chrome vanadium steel with proper heat treatment for extra durability and strength
- Satin chrome plated finish for extra rust resistance
- Supplied with 137pcs 1/4", 3/8", 1/2" hand tools
- Recommended for automotive, truck industry and maintenance uses

CONTENTS (137pcs)		
10PCS	1/4" DR SOCKET CR-V	4,5,6,7,8,9,10,11,12,13 mm
8PCS	3/8" DR.SOCKET CR-V8	8,10,12,13,14,15,17,19,22 mm
15PCS	1/2" DR SOCKET CR-V	8,10,11,12,13,14,15,17,19,21,22,24,27,30,32 mm
5PCS	1/4" DR.DEEP SOCKET CR-V	6,8,10,12,13 mm
9PCS	3/8" DR.DEEP SOCKET CR-V	8,10,12,13,14,15,17,19,22 mm
8PCS	1/2" DR.DEEP SOCKET DR-V	13,14,15,17,19,21,22,24 mm
6PCS	1/4" DR.BITS NUT DRIVER	6,7,8,9,10,11 mm
1PC	1/4" DR.* EXTENSION BAR CR-V	3"
2PCS	3/8" DR.*EXTENSION BAR CR-V	3" & 6"
1PC	1/2" DR *EXTENSION BAR CR-V	5"
1PC	1/2" DR SPARK PLUG CR-V	16 mm
1PC	1/2" DR SPARK PLUG CR-V	21 mm
1PC	1/4"M *ADAPTER CR-V	3/8"F
1PC	3/8"M * ADAPTER CR-V	1/2"F
1PC	1/2" DR RATCHET HANDLE CR-V	45T
1PC	3/8" DR.RATCHET HANDLE CR-V	45T
1PC	1/4" DR.RATCHET HANDLE CR-V	45T
14PCS	COMBINATION WRENCH	8,9,10,11,12,13,14,15,16,17,19,22,24,27 mm
8PCS	HEX KEY	1.5,2,2.5,3,3.5,4,5,6 mm
40PCS	BIT HOLDER	
1PC	BIT DRIVER	
1PC	6" MAGNETIC TRAY	
CARRYING CASE		

ITEM CODE	DESCRIPTION	QTY/CTN	PRICE
MK-TOL-46137-06P	137 Pcs Socket Wrench Set	2	1,220.00



MK-TOL-46144

144 PCS SOCKET WRENCHES SET

1/4" 1/2"    

-  **Professional**
Industrial tooling that has enhanced features and benefits demanded by craftsmen and professional users.
-  **Industrial**
Designed for regular use in industrial applications. Manufactured to stringent quality levels and international standards.
-  **Production**
High performance industrial tooling designed for continuous use applications on machine tools where repeatability and long life are of critical importance.
-  **Workshop**
Standard quality tooling for use by tradesmen and generally domestic use.
-  **Maintenance**
Products designed for general maintenance of machines, workshops, garage and some household applications.
-  **Renovator**
Designed for renovator use and light industrial applications.
-  **Contractor**
Designed for maximum performance required for all applications.



- High grade chrome vanadium steel with proper heat treatment for extra durability and strength
- Satin chrome plated finish for extra rust resistance
- Supplied with 144pcs 1/4", 1/2" hand tools
- Recommended for renovators, contractors, automotive workshop and production sector

1/4" DRIVER				
13PCS	SOCKET 4,4,5,5,5,5,6,7,8,9,10,11,12,13,14MM			
2PCS	EXTENSION BAR 2" 4"			
1PC	RATCHET HANDLE			
1PC	UNIVERSAL JOINT			
1PC	COUPLER			
1PC	SPINNER HANDLE			
30PCS	BIT SET (+)0,1,2,3,4,(*)0,1,2,3,4 (T)10,15,20,25,27,30 (-)3,4,4,4,5,5,5,5,6,7 (H)1,5,2,2,5,3,4,5,6 QUICK CHUCK			
1/2" DRIVER				
13PCS	SOCKET 12,13,14,16,17,18,19,20,22,24,27,30,32MM			
1PC	EXTENSION BAR 5"			
2PCS	SPARK PLUG SOCKET 16,21MM			
1PC	RATCHET HANDLE			
1PC	UNIVERSAL JOINT			
TOOLS & ACCESSORIES				
9PCS	HEX KEY SET 1,5,2,2,5,3,4,5,6,8,10MM			
1PC	HACK SAW 6"			
1PC	HAMMER 300 GM			
1PC	MEASURING TAPE 16FT/5M			
6PCS	SCREWDRIVERS PH1X75MM, PH2X38MM, PH2X100MM, SL6.5X38MM, SL6.5X100MM SL8X150MM			
9PCS	COMBINATION WRENCH 8, 10,11,12,13,14,17,19,22MM			
40PCS	TERMINAL 40PC			
1PC	AUTO VOLTAGE TESTER	1PC	UTILITY KNIFE	
1PC	UTILITY SNIPS 7"	1PC	LONG NOSE PLIER	6"
1PC	DIAGONAL CUTTER PLIER 6"	1PC	COMBINATION PLIER	6"
1PC	WATER PUMP PLIER 10"	1PC	ADJUSTABLE WRENCH	10"
1PC	CRIMPING TOOL 9"			
CARRYING CASE				

ITEM CODE	DESCRIPTION	QTY/CTN	PRICE
MK-TOL-46144-06P	144 Pcs Socket Wrench Set	2	1,280.00

MK-TOL-4627

27 PCS SOCKET WRENCHES SET

1/2"    



Suitable for:

-  **Professional**
Industrial tooling that has enhanced features and benefits demanded by craftsmen and professional users.
-  **Workshop**
Standard quality tooling for use by tradesmen and generally industrial use.
-  **Industrial**
Designed for regular use in industrial applications. Manufactured to stringent quality levels and international standards.
-  **Maintenance**
Products designed for general maintenance of machines, workshops, garage and some household applications.

- High grade chrome vanadium steel with proper heat treatment for extra durability and strength
- Satin chrome plated finish for extra rust resistance
- Basic tools for general application

CONTENTS (26pcs)		
20PCS	1/2" DR SOCKET CR-V	8,9,10,11,12,13,14,15,16,17,18,19, 20,21,22,23,24,27,30,32 mm
2PCS	1/2" DR.EXTENSION BAR	5" & 10"
2PCS	1/2" DR.SPARK PLUG SOCKET	16 mm & 21mm
1PC	1/2" RATCHET HANDLE	
1PC	1/2" DR.UNIVERSAL JOINT	
1PC	1/2" DR.3 WAY AD.	
CARRYING CASE		

ITEM CODE	DESCRIPTION	QTY/CTN	PRICE
MK-TOL-4627-06P	27 Pcs Socket Wrenches Set	4	378.00
MK-TOL-4627-12P	27 Pcs Socket Wrenches Set	4	378.00



MK-TOL-4631

31PCS SOCKET WRENCHES SET

1/2"



Suitable for:



- High grade chrome vanadium steel with proper heat treatment for extra durability and strength
- Satin chrome plated finish for extra rust resistance
- Basic tools for general application

CO NTENTS (31pcs)		
1PC	1/2" DR.RATCHET HANDLE	
15PCS	1/2" DR.SOCKET	8,10,11,12,13,14,15,17,18,19,22,24,27,
10PCS	COMBINATION WRENCH	8,9,10,11,12,13,14,17,18,19 mm
2PCS	1/2" DR.EXTENSION BAR	125mm and 250mm
1PC	3-WAY ADAPTER	3/8"(F) X 1/2" (M)
2PCS	1/2" DR.SPARK PLUG SOCKET	16mm and 21mm
CARRYING CASE		

ITEM CODE	DESCRIPTION	QTY/CTN	PRICE
MK-TOL-4631	31 Pcs 1/2" Dr.Socket Set (6P)	4	458.00

MK-TOL-4641

41 PCS SOCKET WRENCHES SET

1/2"



Suitable for:



- High grade chrome vanadium steel with proper heat treatment for extra durability and strength
- Satin chrome plated finish for extra rust resistance
- Basic tools for general application

CO NTENTS (41pcs)		
18PCS	1/2" DR SOCKET CR-V	10,11,12,13,14,15,16,17,18,19,20,21,22,23,24,27,30,32 mm
7PCS	1/2" DR DEEP SOCKET CR-V	8,10,12,13,14,17,19 mm
1PC	1/2" DR EXTENSION BAR CR-V	*5" & *10"
1PC	1/2" DR SPARK PLUG CR-V	16mm & 21mm
1PC	1/2" DR RATCHET HANDLE CR-V	72T
1PC	1/2" UNIVERSAL JOINT CR-V	
1PC	1/2" DR SLIDING T HANDLE CR-V	250mm
9PCS	COMBINATION WRENCH CR-V	8,10,11,12,13,14,17,19,22 mm
CARRYING CASE		

ITEM CODE	DESCRIPTION	QTY/CTN	PRICE
MK-TOL-4641	41 Pcs Socket Wrench Set	4	550.00



MK-TOL-4927M 27PCS SPLINE SOCKET SET

1/2"



Suitable for:



- High grade chrome vanadium steel with proper heat treatment for extra durability and strength
- Satin chrome plated finish for extra rust resistance
- Ideal for tightening and removing of spline, 4 point, 6 point, 12 point, star and even 50% rounded off fasteners
- Perfect for automotive workshop

CONTENTS (27pcs)		
20PCS	1/2" Dr.Socket	8, 9, 10, 11, 12, 13, 14, 15, 16, 17, 18, 19, 20, 21, 22, 23, 24, 27, 30, 32mm
1PC	1/2" Dr.Ratchet Handle	
1PC	1/2" Dr.Universal Joint	
2PCS	1/2" Dr.Extension Bar	75mm,250mm
1PC	1/2" Dr.Sliding T Bar	250mm
2PCS	1/2" Dr.Spark Plug Socket	16mm,21mm
CARRYING CASE		



ITEM CODE	DESCRIPTION	QTY/CTN	PRICE
MK-TOL-4927M	27 Pcs 1/2" Dr. Spline Socket Set	5	533.00

MK-TOL-6120N* MK-TOL-6120NQ RATCHET HANDLE



3/4"



L = 500mm/20" = 1850g



TYPE	D(mm)	T(mm)	TEETH
6120N/6120NQ	62	54	24

- Chrome vanadium steel with proper heat treatment for extra durability and strength
- Chrome plated finish for extra rust resistance
- Features with ultra-smooth 45 teeth ratchet action allowing ratcheting use in restricted area (8 °)
- Quick release push button provide extra safety and efficient operation.

ITEM CODE	DESCRIPTION	QTY/CTN	PRICE
MK-TOL-6120N	Ratchet Handle	10	378.00
MK-TOL-6120NQ	Ratchet Handle	10	430.30

MK-TOL-6130N RATCHET HANDLE*

3/4"



L = 500mm/20" = 2200g



- Chrome vanadium steel, chrome plated finish.

ITEM CODE	DESCRIPTION	QTY/CTN	PRICE
MK-TOL-6130N	Ratchet Handle	10	261.70

MK-TOL-6200 UNIVERSAL JOINT

3/4"



L=110mm/4-5/16" =590g



- Chrome vanadium steel, polished chrome plated finish.
- Spring action for presetting the socket at the desired working angle.

ITEM CODE	DESCRIPTION	QTY/CTN	PRICE
MK-TOL-6200	Universal Joint	20	200.50



MK-TOL-6617 17 PCS SOCKET WRENCHES SET

3/4"



17PCS	6617M
6400 (6402)	19, 21, 22, 23, 24, 27, 30, 32, 36, 38, 41, 46, 50. 13PC SOCKETS
6130N	REVERSIBLE RATCHET HANDLES, 500mm
6770	SLIDING "T" BAR, 450mm
6800-4	EXTENSION BAR, 100mm
6800-8	EXTENSION BAR, 200mm
METAL CASE 534x178x78mm 1 SET=13KGS G.W. 14KGS/1SET CUFT=0.47'	

- High grade chrome vanadium steel with proper heat treatment for extra durability and strength
- Satin chrome plated finish for extra rust resistance
- Supplied with 3/4" hand tools and socket
- Recommended for light truck, buses, forklift, heavy equipment industry repair and maintenance uses

ITEM CODE	DESCRIPTION	QTY/CTN	PRICE
MK-TOL-6617	17 Pcs Socket Wrench Set	1	1,218.00

MK-TOL-6700N FLEXIBLE HANDLE

3/4"



L = 475mm/19" \square = 1850g



- Chrome vanadium steel with proper heat treatment for extra durability and strength
- Chrome plated finish for extra rust resistance

ITEM CODE	DESCRIPTION	QTY/CTN	PRICE
MK-TOL-6700N	Flexible Handle	12	254.00

MK-TOL-6770 SLIDING "T" HANDLE

3/4"



L = 500mm/20" \square = 1500g



- Chrome vanadium steel with proper heat treatment for extra durability and strength
- Chrome plated finish for extra rust resistance

ITEM CODE	DESCRIPTION	QTY/CTN	PRICE
MK-TOL-6770	Sliding "T" Handle	10	157.70

MK-TOL-6402M 12-POINT SOCKET



3/4"

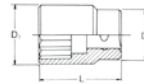

- High grade of chrome vanadium steel with proper heat treatment for extra durability and strength
- Satin chrome plated finish for extra rust resistance
- Knurled ring design for extra grip with oily finger
- Thin wall design allow users operate in tight area

Item Code	6402M (mm)	D1 mm	D2 mm	L mm	\square g	Qty/Ctn	Price
MK-6402M-17	17	27	38	51	270	50	33.60
MK-6402M-18	18	28	38	51	270	50	33.60
MK-6402M-19	19	29	38	51	280	50	33.60
MK-6402M-20	20	30	38	51	280	50	33.60
MK-6402M-21	21	32	38	51	280	50	33.60
MK-6402M-22	22	33	40	51	290	50	33.60
MK-6402M-23	23	34	40	51	300	50	33.60
MK-6402M-24	24	35	40	51	300	50	33.60
MK-6402M-25	25	37	40	54	310	50	34.70
MK-6402M-26	26	38	41	54	320	50	36.00
MK-6402M-27	27	39	42	54	330	50	36.00
MK-6402M-28	28	42	38	54	330	50	37.60
MK-6402M-29	29	42	39	54	340	50	37.60
MK-6402M-30	30	43	40	54	370	50	40.30
MK-6402M-31	31	44	41	54	380	50	40.30
MK-6402M-32	32	45	42	57	420	40	42.20
MK-6402M-33	33	47	43	57	440	40	45.60
MK-6402M-34	34	48	43	57	470	40	47.00
MK-6402M-35	35	49	44	57	490	40	47.00
MK-6402M-36	36	50	44	57	510	45	51.10
MK-6402M-38	38	53	44	57	550	36	52.50
MK-6402M-40	40	55	44	58	580	36	55.70
MK-6402M-41	41	57	44	58	590	24	55.70
MK-6402M-43	43	57	44	58	590	24	64.90
MK-6402M-45	45	63	44	63	730	24	64.90
MK-6402M-46	46	63	44	63	730	24	72.50
MK-6402M-48	48	65	44	65	770	24	78.80
MK-6402M-50	50	68	44	68	820	16	78.80
MK-6402M-52	52	70	54	70	860	16	93.50
MK-6402M-54	54	73	54	73	910	16	93.50
MK-6402M-55	55	74	54	73	1030	16	93.50
MK-6402M-60	60	80	60	80	1450	16	113.40
MK-6402M-65	65	86	60	85	1750	16	162.80
MK-6402M-70	70	92	60	90	1950	16	184.80

MK-TOL-6777 L-HANDLE(CHROME)

3/4"



- Chrome vanadium steel with proper heat treatment for extra durability and strength
- Chrome plated finish for extra rust resistance

ITEM CODE	DESCRIPTION	QTY/CTN	PRICE
MK-TOL-6777-300	L=300mm/12" \square =1380g	20	99.20
MK-TOL-6777-450	L=450mm/18" \square =1850g	20	133.60



MK-TOL-6800 EXTENSION BAR

3/4"



- Chrome vanadium steel with proper heat treatment for extra durability and strength
- Chrome plated finish for extra rust resistance

ITEM CODE	MM	INCH	Weight	QTY/CTN	PRICE
MK-TOL-6800-100	100	4"	400g	50	55.30
MK-TOL-6800-200	200	8"	700g	20	72.00
MK-TOL-6800-400	400	16"	1400g	10	121.90

MK-TOL-8100N RATCHET HANDLE

1"



L=650mm/26" Weight = 4050g



- Chrome vanadium steel with proper heat treatment for extra durability and strength
- Chrome plated finish for extra rust resistance

ITEM CODE	DESCRIPTION	QTY/CTN	PRICE
MK-TOL-8100N	Ratchet Handle	6	990.00

MK-TOL-8700N FLEXIBLE HANDLE

1"



L=650mm/26"



- Chrome vanadium steel with proper heat treatment for extra durability and strength
- Chrome plated finish for extra rust resistance

ITEM CODE	DESCRIPTION	QTY/CTN	PRICE
MK-TOL-8700N	Flexible Handle	6	936.70

MK-TOL-8777 L-HANDLE

1"



L = 550mm/22" Weight = 1850g



- Chrome vanadium steel with proper heat treatment for extra durability and strength
- Chrome plated finish for extra rust resistance

ITEM CODE	L	Weight	QTY/CTN	PRICE
MK-TOL-8777-550	550mm/22"	1850g	8	378.70

MK-TOL-6804 ADAPTOR 3/4"

Weight = 200g

MK-TOL-6805 ADAPTOR 3/4"

Weight = 380g



- Chrome vanadium steel with proper heat treatment for extra durability and strength
- Chrome plated finish for extra rust resistance with ball locking
- Maximum permission torque: 202Nm

ITEM CODE	DESCRIPTION	QTY/CTN	PRICE
MK-TOL-6804	Adaptor	50	51.00
MK-TOL-6805	Adaptor	50	65.10

MK-TOL-8200 UNIVERSAL JOINT

1"



L=143mm/5-3/4" Weight = 1150g



- Chrome vanadium steel with proper heat treatment for extra durability and strength
- Chrome plated finish for extra rust resistance
- Spring action for presetting the socket in the desired working angle

ITEM CODE	DESCRIPTION	QTY/CTN	PRICE
MK-TOL-8200	Universal Joint	12	374.90

MK-TOL-8770 SLIDING "T" HANDLE

1"



- Chrome vanadium steel with proper heat treatment for extra durability and strength
- Chrome plated finish for extra rust resistance

ITEM CODE	L	Weight	QTY/CTN	PRICE
MK-TOL-8770-550	550mm/22"	3300g	6	401.80
MK-TOL-8770-630	630mm/25"	3700g	6	442.90
MK-TOL-8770-762	762mm/30"	4350g	6	495.00

MK-TOL-8800 EXTENSION BAR

1"



- Chrome vanadium steel with proper heat treatment for extra durability and strength
- Chrome plated finish for extra rust resistance

ITEM CODE	MM	INCH	Weight	QTY/CTN	PRICE
MK-TOL-8800-200	200	8"	1350g	12	213.70
MK-TOL-8800-400	400	16"	2480g	6	363.00



MK-SET-BIT001 09 PCS BIT SOCKET SET (84016M)



CONTENTS
MK-EQP-077 1/2" DR 9pcs DEEP IMPACT SOCKET STRIPS SET
MK-TOL-84016M IMPACT HEXAGON BIT SOCKET 04mm, 5mm, 6mm, 7mm, 8mm, 9mm, 10mm, 11mm, 12mm

ITEM CODE	DESCRIPTION	QTY/CTN	PRICE
MK-SET-BIT001	09 PCS BIT SOCKET SET (84016M)		254.20

MK-SET-BIT004 07 PCS BIT SOCKET SET (84014)



CONTENTS
MK-EQP-075 1/2" DR 7pcs DEEP IMPACT SOCKET STRIPS SET
MK-TOL-84014 IMPACT STAR BIT SOCKET T45, T47, T50, T55, T60, T70, T80

ITEM CODE	DESCRIPTION	QTY/CTN	PRICE
MK-SET-BIT004	07 PCS BIT SOCKET SET (84014)		186.90

MK-SET-BIT006 07 PCS BIT SOCKET SET (4026M)



CONTENTS
MK-EQP-076 1/2" DR 7pcs DEEP SOCKET STRIPS SET
MK-TOL-4026M 1/2" HEX BIT SOCKET 04mm, 05mm, 06mm, 07mm, 08mm, 09mm, 10mm

ITEM CODE	DESCRIPTION	QTY/CTN	PRICE
MK-SET-BIT006	07 PCS BIT SOCKET SET (4026M)		76.90

MK-SET-BIT002 09 PCS BIT SOCKET SET (84014)



CONTENTS
MK-EQP-077 1/2" DR 9pcs DEEP IMPACT SOCKET STRIPS SET
MK-TOL-84014 IMPACT STAR BIT SOCKET T25, T27, T30, T40, T45, T47, T50, T55, T60

ITEM CODE	DESCRIPTION	QTY/CTN	PRICE
MK-SET-BIT002	09 PCS BIT SOCKET SET (84014)		274.60

MK-SET-BIT005 07 PCS BIT SOCKET SET (4024M)



CONTENTS
MK-EQP-076 1/2" DR 7pcs DEEP SOCKET STRIPS SET
MK-TOL-4024M 1/2" STAR BIT SOCKET T20, T25, T27, T30, T40, T45, T47

ITEM CODE	DESCRIPTION	QTY/CTN	PRICE
MK-SET-BIT005	07 PCS BIT SOCKET SET (4024M)		113.80

MK-SET-BIT007 07 PCS BIT SOCKET SET (4028)



CONTENTS
MK-EQP-076 1/2" DR 7pcs DEEP SOCKET STRIPS SET
MK-TOL-4028 1/2" SPLINE BIT SOCKET 05mm, 06mm, 08mm, 10mm, 12mm, 14mm, 16mm

ITEM CODE	DESCRIPTION	QTY/CTN	PRICE
MK-SET-BIT007	07 PCS BIT SOCKET SET (4028)		142.20



MK-SET-BIT008 05 PCS BIT SOCKET SET (84014)



CONTENTS	
MK-EQP-054	1/2" DR 5pcs DEEP SOCKET STRIPS SET
MK-TOL-84014	IMPACT STAR BIT SOCKET
T50, T55, T60, T70, T80	

ITEM CODE	DESCRIPTION	QTY/CTN	PRICE
MK-SET-BIT008	05 PCS BIT SOCKET SET (84014)		156.40

MK-SET-BIT009 05 PCS BIT SOCKET SET (84016M)



CONTENTS	
MK-EQP-054	1/2" DR 5pcs DEEP SOCKET STRIPS SET
MK-TOL-84016M	IMPACT HEXAGON BIT SOCKET
16mm, 17mm, 18mm, 19mm, 21mm	

ITEM CODE	DESCRIPTION	QTY/CTN	PRICE
MK-SET-BIT009	05 PCS BIT SOCKET SET (84016M)		138.40

MK-SET-BIT011 05 PCS BIT SOCKET SET (4024M)



CONTENTS	
MK-EQP-054	1/2" DR 5pcs DEEP SOCKET STRIPS SET
MK-TOL-4024M	1/2" STAR BIT SOCKET
T50, T55, T60, T70, T80	

ITEM CODE	DESCRIPTION	QTY/CTN	PRICE
MK-SET-BIT011	05 PCS BIT SOCKET SET (4024M)		124.80

MK-SET-BIT012 05 PCS BIT SOCKET SET (4028)



CONTENTS	
MK-EQP-054	1/2" DR 5pcs DEEP SOCKET STRIPS SET
MK-TOL-4028	1/2" SPLINE BIT SOCKET
08mm, 10mm, 12mm, 14mm, 16mm	

ITEM CODE	DESCRIPTION	QTY/CTN	PRICE
MK-SET-BIT012	05 PCS BIT SOCKET SET (4028)		110.60

MK-SET-HAN001 20 PCS BIT SOCKET SET (4400M 6P)



CONTENTS	
MK-EQP-050	1/2" DR 20pcs SOCKET STRIPS SET
MK-TOL-4400M	1/2" 6 POINT SOCKET-S
10mm, 11mm, 12mm, 13mm, 14mm, 15mm, 16mm, 17mm, 18mm, 19mm, 20mm, 21mm, 22mm, 23mm, 24mm, 25mm, 26mm, 27mm	
MK-TOL-4120NQ	250mm 1/2" QUICK RELEASE
MK-TOL-4777-CHR	260mm 1/2" L-HANDLE (CHR)

ITEM CODE	DESCRIPTION	QTY/CTN	PRICE
MK-SET-HAN001	20 PCS SOCKET SET (4400M 6P)		265.50

MK-SET-HAN002 20 PCS SOCKET SET (4402M 12P)



CONTENTS	
MK-EQP-050	1/2" DR 20pcs SOCKET STRIPS SET
MK-TOL-4402M	1/2" 12 POINT SOCKET-S
10mm, 11mm, 12mm, 13mm, 14mm, 15mm, 16mm, 17mm, 18mm, 19mm, 20mm, 21mm, 22mm, 23mm, 24mm, 25mm, 26mm, 27mm	
MK-TOL-4120NQ	250mm 1/2" QUICK RELEASE
MK-TOL-4777-CHR	260mm 1/2" L-HANDLE (CHR)

ITEM CODE	DESCRIPTION	QTY/CTN	PRICE
MK-SET-HAN002	20 PCS SOCKET SET (4402M 12P)		265.50



MK-SET-HAN003

20 PCS BIT SOCKET SET (4400M 6P)



CONTENTS	
MK-EQP-050	1/2" DR 20pcs SOCKET STRIPS SET
MK-TOL-4400M	1/2" 6 POINT SOCKET-S 08mm, 09mm, 10mm, 11mm, 12mm, 13mm, 14mm, 15mm, 16mm 17mm, 18mm, 19mm, 20mm, 21mm, 22mm, 23mm, 24mm, 27mm
MK-TOL-4800	250mm 1/2" EXTENSION BAR
MK-TOL-4777-CHR	260mm 1/2" L-HANDLE (CHR)

ITEM CODE	DESCRIPTION	QTY/CTN	PRICE
MK-SET-HAN003	20 PCS SOCKET SET (4400M 6P)		209.40

MK-SET-HAN004

20 PCS SOCKET SET (4402M 12P)



CONTENTS	
MK-EQP-050	1/2" DR 20pcs SOCKET STRIPS SET
MK-TOL-4402M	1/2" 12 POINT SOCKET-S 08mm, 09mm, 10mm, 11mm, 12mm, 13mm, 14mm, 15mm, 16mm 17mm, 18mm, 19mm, 20mm, 21mm, 22mm, 23mm, 24mm, 27mm
MK-TOL-4800	250mm 1/2" EXTENSION BAR
MK-TOL-4777-CHR	260mm 1/2" L-HANDLE (CHR)

ITEM CODE	DESCRIPTION	QTY/CTN	PRICE
MK-SET-HAN004	20 PCS SOCKET SET (4402M 12P)		209.40

MK-SET-HAN009

20 PCS BIT SOCKET SET (4400M 6P)



CONTENTS	
MK-EQP-051	1/2" DR 12pcs SOCKET STRIPS SET
MK-TOL-4400M	1/2" 6 POINT SOCKET-S 08mm, 09mm, 10mm, 11mm, 12mm, 13mm, 14mm, 15mm, 16mm, 17mm
MK-TOL-4120NQ	250mm 1/2" QUICK RELEASE
MK-TOL-4777-CHR	260mm 1/2" L-HANDLE (CHR)

ITEM CODE	DESCRIPTION	QTY/CTN	PRICE
MK-SET-HAN009	20 PCS SOCKET SET (4400M 6P)		160.60

MK-SET-HAN010

20 PCS SOCKET SET (4402M 12P)



CONTENTS	
MK-EQP-051	1/2" DR 12pcs SOCKET STRIPS SET
MK-TOL-4402M	1/2" 12 POINT SOCKET-S 08mm, 09mm, 10mm, 11mm, 12mm, 13mm, 14mm, 15mm, 16mm, 17mm
MK-TOL-4120NQ	250mm 1/2" QUICK RELEASE
MK-TOL-4777-CHR	260mm 1/2" L-HANDLE (CHR)

ITEM CODE	DESCRIPTION	QTY/CTN	PRICE
MK-SET-HAN010	20 PCS SOCKET SET (4402M 12P)		160.60

MK-SET-HAN017

9 PCS BIT SOCKET SET (4400M 6P)



CONTENTS	
MK-EQP-070	1/2" DR 9pcs SOCKET STRIPS SET
MK-TOL-4400M	1/2" 6 POINT SOCKET-S 08mm, 09mm, 10mm, 11mm, 12mm, 13mm, 14mm, 17mm, 19mm

ITEM CODE	DESCRIPTION	QTY/CTN	PRICE
MK-SET-HAN017	09 PCS SOCKET SET (4400M 6P)		61.80

MK-SET-HAN018

9 PCS SOCKET SET (4402M 12P)



CONTENTS	
MK-EQP-070	1/2" DR 9pcs SOCKET STRIPS SET
MK-TOL-4402M	1/2" 12 POINT SOCKET-S 08mm, 09mm, 10mm, 11mm, 12mm, 13mm, 14mm, 17mm, 19mm

ITEM CODE	DESCRIPTION	QTY/CTN	PRICE
MK-SET-HAN018	09 PCS SOCKET SET (4402M 12P)		61.80



MK-SET-HAN021

7 PCS BIT SOCKET SET (4300M 6P)



CONTENTS	
MK-EQP-069	1/2" DR 7pcs SOCKET STRIPS SET
MK-TOL-4300M	1/2" 6 POINT SOCKET 08mm, 10mm, 12mm, 13mm, 14mm, 17mm, 19mm

ITEM CODE	DESCRIPTION	QTY/CTN	PRICE
MK-SET-HAN021	07 PCS SOCKET SET (4300M 6P)		92.30

MK-SET-HAN022

7 PCS SOCKET SET (4302M 12P)



CONTENTS	
MK-EQP-069	1/2" DR 7pcs SOCKET STRIPS SET
MK-TOL-4302M	1/2" 12 POINT SOCKET 08mm, 10mm, 12mm, 13mm, 14mm, 17mm, 19mm

ITEM CODE	DESCRIPTION	QTY/CTN	PRICE
MK-SET-HAN022	07 PCS SOCKET SET (4402M 12P)		92.30

MK-SET-HAN027

5 PCS BIT SOCKET SET (4400M 6P)



CONTENTS	
MK-EQP-068	1/2" DR 5pcs SOCKET STRIPS SET
MK-TOL-4400M	1/2" 6-POINT SOCKET-S 08mm, 10mm, 12mm, 14mm, 17mm

ITEM CODE	DESCRIPTION	QTY/CTN	PRICE
MK-SET-HAN027	05 PCS SOCKET SET (4400M 6P)		34.50

MK-SET-HAN028

5 PCS SOCKET SET (4402M 12P)



CONTENTS	
MK-EQP-068	1/2" DR 5pcs SOCKET STRIPS SET
MK-TOL-4402M	1/2" 12-POINT SOCKET-S 08mm, 10mm, 12mm, 14mm, 17mm

ITEM CODE	DESCRIPTION	QTY/CTN	PRICE
MK-SET-HAN028	05 PCS SOCKET SET (4402M 12P)		34.50

MK-SET-HAN029

7 PCS BIT SOCKET SET (4400M 6P)



CONTENTS	
MK-EQP-069	1/2" DR 7PCS SOCKET STRIPS SET
MK-TOL-4400M	1/2" 6-POINT SOCKET-S 08mm, 10mm, 12mm, 14mm, 17mm, 19mm, 21mm

ITEM CODE	DESCRIPTION	QTY/CTN	PRICE
MK-SET-HAN029	07 PCS SOCKET SET (4400M 6P)		53.80

MK-SET-HAN030

7 PCS SOCKET SET (4402M 12P)



CONTENTS	
MK-EQP-069	1/2" DR 7PCS SOCKET STRIPS SET
MK-TOL-4402M	1/2" 12-POINT SOCKET-S 08mm, 10mm, 12mm, 14mm, 17mm, 19mm, 21mm

ITEM CODE	DESCRIPTION	QTY/CTN	PRICE
MK-SET-HAN030	7 PCS SOCKET SET (4402M 12P)		53.80



MK-SET-HAN031 7 PCS BIT SOCKET SET (4300M 6P)



CONTENTS	
MK-EQP-069	1/2" DR 7PCS SOCKET STRIPS SET
MK-TOL-4300M	1/2" 6-POINT SOCKET-L 08mm, 10mm, 12mm, 14mm, 17mm, 19mm, 21mm

ITEM CODE	DESCRIPTION	QTY/CTN	PRICE
MK-SET-HAN031	7 PCS SOCKET SET (4300M 6P)		95.40

MK-SET-HAN032 7 PCS SOCKET SET (4302M 12P)



CONTENTS	
MK-EQP-069	1/2" DR 7PCS SOCKET STRIPS SET
MK-TOL-4302M	1/2" 12-POINT SOCKET-L 08mm, 10mm, 12mm, 14mm, 17mm, 19mm, 21mm

ITEM CODE	DESCRIPTION	QTY/CTN	PRICE
MK-SET-HAN032	7 PCS SOCKET SET (4302M 12P)		95.40

MK-SET-HAN033 5 PCS BIT SOCKET SET (4400M 6P)



CONTENTS	
MK-EQP-068	1/2" DR 5pcs SOCKET STRIPS SET
MK-TOL-4400M	1/2" 6-POINT SOCKET-S 12mm, 14mm, 17mm, 19mm, 21mm

ITEM CODE	DESCRIPTION	QTY/CTN	PRICE
MK-SET-HAN033	5 PCS SOCKET SET (4400M 6P)		41.80

MK-SET-HAN034 5 PCS SOCKET SET (4402M 12P)



CONTENTS	
MK-EQP-068	1/2" DR 5pcs SOCKET STRIPS SET
MK-TOL-4402M	1/2" 12-POINT SOCKET-S 12mm, 14mm, 17mm, 19mm, 21mm

ITEM CODE	DESCRIPTION	QTY/CTN	PRICE
MK-SET-HAN034	5 PCS SOCKET SET (4402M 12P)		41.80

MK-SET-HAN035 5 PCS BIT SOCKET SET (4300M 6P)



CONTENTS	
MK-EQP-054	1/2" DR 5pcs DEEP SOCKET STRIPS SET
MK-TOL-4300M	1/2" 6-POINT SOCKET-L 10mm, 12mm, 14mm, 17mm, 19mm

ITEM CODE	DESCRIPTION	QTY/CTN	PRICE
MK-SET-HAN035	5 PCS SOCKET SET (4400M 6P)		67.70

MK-SET-HAN036 5 PCS SOCKET SET (4302M 12P)



CONTENTS	
MK-EQP-054	1/2" DR 5pcs DEEP SOCKET STRIPS SET
MK-TOL-4302M	1/2" 12-POINT SOCKET-S 10mm, 12mm, 14mm, 17mm, 19mm

ITEM CODE	DESCRIPTION	QTY/CTN	PRICE
MK-SET-HAN036	5 PCS SOCKET SET (4402M 12P)		67.70



MK-SET-IMP004
10 PCS IMPACT SOCKET SET
(84400M 6P)



CONTENTS	
MK-EQP-052	1/2" DR 10pcs IMPACT SOCKET STRIPS SET
MK-TOL-84400M	1/2" IMPACT SOCKET-S 10mm, 12mm, 13mm, 14mm, 15mm, 17mm, 18mm, 19mm, 20mm, 21mm

ITEM CODE	DESCRIPTION	QTY/CTN	PRICE
MK-SET-IMP004	10 PCS Impact Socket Set (84400M 6P)		154.20

MK-SET-IMP006
10 PCS IMPACT SOCKET SET
(84400M 6P)



CONTENTS	
MK-EQP-052	1/2" DR 10pcs IMPACT SOCKET STRIPS SET
MK-TOL-84300M	1/2" DEEP IMPACT SOCKET 10mm, 12mm, 13mm, 14mm, 15mm, 17mm, 18mm, 19mm, 20mm, 21mm

ITEM CODE	DESCRIPTION	QTY/CTN	PRICE
MK-SET-IMP006	10 PCS Impact Socket Set (84400M 6P)		223.90

IMPACT SOCKETS AND ACCESSORIES

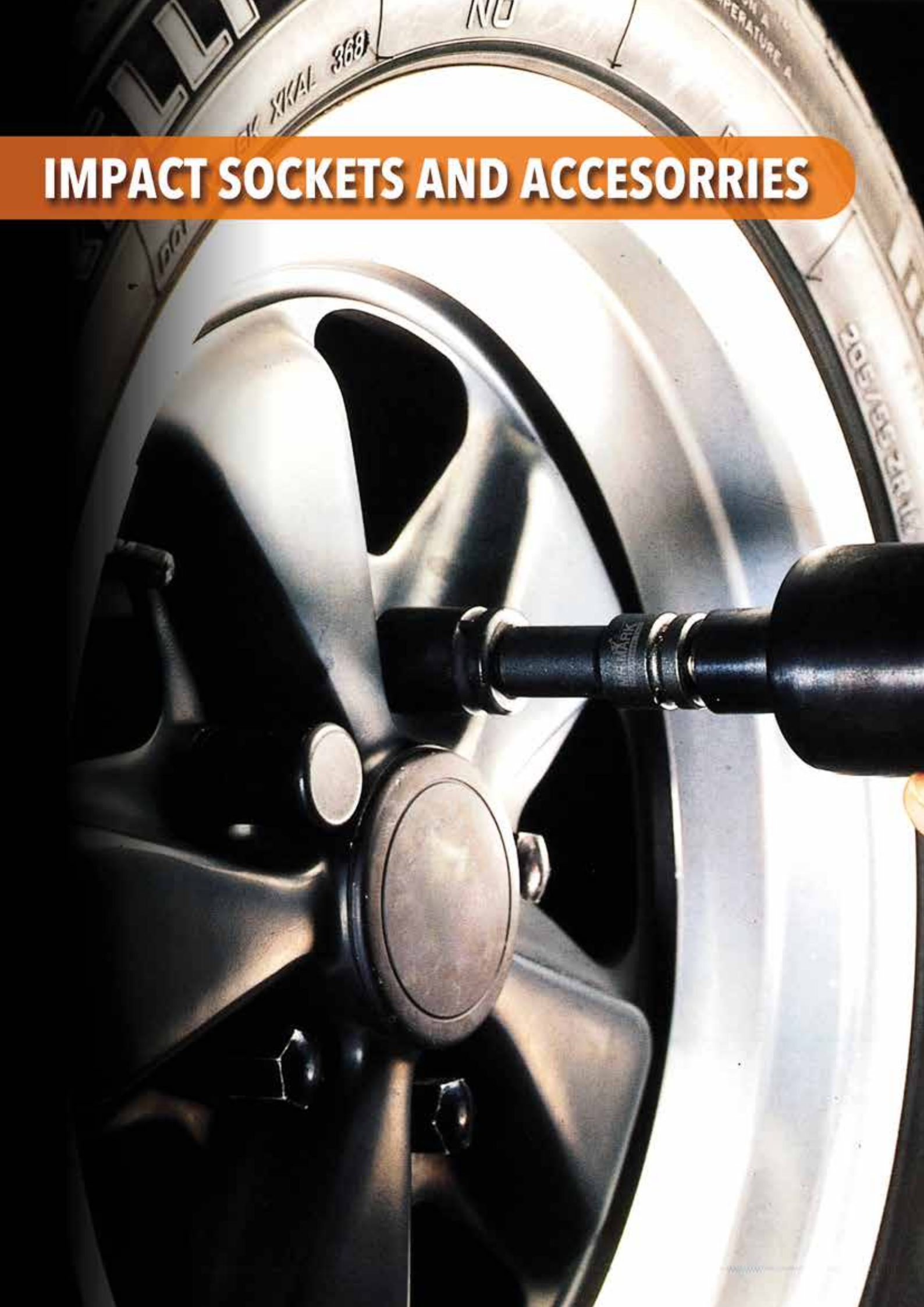

Sockets

Personal safety with impact sockets !

- Always secure sockets to the machine with locking ring and pin (references given for each socket). Never hold a socket or accessory while the machine is turning.

NEVER USE A MANUAL OR SIMPLE MACHINE SOCKET ON A POWER IMPACT TOOL.



- Only use impact sockets when locked

Impact Sockets Safety Uses

- Do not use hand sockets with impact or power-driven tools. Serious injury is possible.
- Use safety goggles. Serious eye injury is possible.
- Do not hammer on sockets or drive tools.
- Do not use extenders or cheater bars.
- Wear gloves and eye protection.
- Make sure that you are well balanced, and pull the tool towards you rather than pushing it.
- Use only recommended extension and do not overload.
- Ratchets are specially designed to speed up rotation. For loosening very tight fasteners, it is preferable to select a sliding tee. Check that ratchet mechanism engagefully.
- Ratchets maintenances is simple and normally requires only cleaning and lubrication to ensure optimum performance.
- Select 6 point socket if fasteners are worn or hardened.
- Check condition of both tool and fastener before use. Do not use tools showing sign of excessive wear or breakage.
- Disconnect electricity when working on electrical parts.
- Prevent slipping. Keep tools clean.



- Don't exceed tool capacity or use oversize extensions.

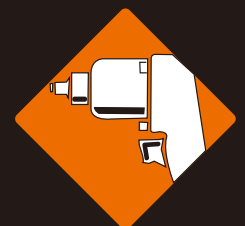



MK-TOL-83000M-06 3/8" 1/4" (6mm)

IMPACT BIT HOLDER*

= 40g

MK-TOL-83001M-08 3/8" 5/16" (8mm)

IMPACT BIT HOLDER*

= 60g



- Chrome molybdenum steel.
- Phosphatised finish.



ITEM CODE	DESCRIPTION	QTY/CTN	PRICE
MK-TOL-83000M-06	3/8" Impact Bit Holder	200	24.50
MK-TOL-83001M-08	3/8" Impact Bit Holder	200	25.00

MK-TOL-83400M

IMPACT SOCKET



3/8"

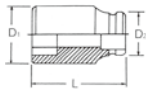

- High grade chrome molybdenum steel with proper heat treatment for extra durability and strength
- Phosphatised finish for extra rust resistance
- Side locking hole

Item Code	83400M (mm)	D1 (mm)	D2 (mm)	L (mm)	(g)	Qty/Ctn	Price
MK-TOL-83400M-08	8	13	19	28	40	400	13.80
MK-TOL-83400M-09	9	14	19	28	42	400	13.80
MK-TOL-83400M-10	10	16	19	28	45	400	13.80
MK-TOL-83400M-11	11	17	19	30	45	400	14.50
MK-TOL-83400M-12	12	18	19	30	45	400	14.50
MK-TOL-83400M-13	13	20	20	30	48	300	14.50
MK-TOL-83400M-14	14	21	21	30	55	300	14.50
MK-TOL-83400M-15	15	22	22	30	70	300	14.80
MK-TOL-83400M-16	16	23	22	30	70	200	15.90
MK-TOL-83400M-17	17	24	22	32	80	200	15.90
MK-TOL-83400M-18	18	26	22	32	90	200	16.20
MK-TOL-83400M-19	19	27	22	32	95	200	17.90
MK-TOL-83400M-20	20	28	22	32	95	200	18.40
MK-TOL-83400M-21	21	29	22	32	100	200	19.70
MK-TOL-83400M-22	22	31	22	32	105	200	24.60

MK-TOL-83804

IMPACT ADAPTOR 3/8"x1/4" L = 35mm, = 60g

MK-TOL-83805

IMPACT ADAPTOR 3/8"x1/2" L = 28mm, = 30g



- Max permissible torsion= 62Nm.

- High grade chrome molybdenum steel with proper heat treatment for extra durability and strength
- Phosphatised finish for extra rust resistance



ITEM CODE	DESCRIPTION	QTY/CTN	PRICE
MK-TOL-83804-3/8x1/4	3/8" Impact Adaptor	200	22.30
MK-TOL-83805-3/8x1/2	3/8" Impact Adaptor	200	22.30

MK-TOL-83200

IMPACT UNIVERSAL JOINT



3/8"

L=65mm =110g



- High grade chrome molybdenum steel with proper heat treatment for extra durability and strength
- Phosphatised finish for extra rust resistance
- Steel ball retainer on male end
- Flexing ability for greater access around obstructions
- Precision cold formed for exact, consistent dimensions and greater strength

ITEM CODE	DESCRIPTION	QTY/CTN	PRICE
MK-TOL-83200-65	3/8" Impact Iniversal Joint	200	53.70

MK-TOL-83800M

IMPACT EXTENSION BAR



3/8"



- High grade chrome molybdenum steel with proper heat treatment for extra durability and strength
- Phosphatised finish for extra rust resistance

ITEM CODE	DESCRIPTION	MM	INCH	(g)	QTY/CTN	PRICE
MK-TOL-83800-075	3/8" Impact Extension Bar	75	3"	90	140	27.80
MK-TOL-83800-125	3/8" Impact Extension Bar	125	5"	140	120	33.40
MK-TOL-83800-200	3/8" Impact Extension Bar	200	8"	210	100	69.10

MK-TOL-84000M-06

IMPACT BIT HOLDER*



1/2"

1/4" (6mm)
= 60g



- Chrome molybdenum steel.
- Phosphatised finish.

ITEM CODE	DESCRIPTION	QTY/CTN	PRICE
MK-TOL-84000M-06	1/2" Impact Bit Holder	200	37.50

MK-TOL-84014

IMPACT STAR BIT SOCKET

1/2"

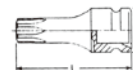

- High grade chrome molybdenum steel with proper heat treatment for extra durability and strength
- Phosphatised finish for extra rust resistance

Item Code	84014 (mm)	D (mm)	84014 L=78mm	Qty/Ctn	Price
MK-TOL-84014-T25	T25	25	70	240	40.80
MK-TOL-84014-T27	T27	25	74	240	40.80
MK-TOL-84014-T30	T30	25	78	240	40.80
MK-TOL-84014-T40	T40	25	92	240	40.80
MK-TOL-84014-T45	T45	25	97	240	40.80
MK-TOL-84014-T47	T47	25	100	240	40.80
MK-TOL-84014-T50	T50	25	110	240	40.80
MK-TOL-84014-T55	T55	25	125	240	40.80
MK-TOL-84014-T60	T60	25	125	120	40.80
MK-TOL-84014-T70	T70	25	125	120	42.90
MK-TOL-84014-T80	T80	25	130	120	42.90



MK-TOL-84016M
IMPACT "FOR INTERNAL HEXAGON"
HEXAGON BIT SOCKET



- High grade chrome molybdenum steel with proper heat treatment for extra durability and strength
- Phosphatised finish for extra rust resistance

Item Code	84016M	D (mm)	L (mm)		Qty/Ctn	Price
	(mm)		84016-3			
MK-TOL-84016M-04	4	22	78	78	240	29.90
MK-TOL-84016M-05	5	22	78	81	240	29.90
MK-TOL-84016M-06	6	22	78	86	240	29.90
MK-TOL-84016M-07	7	22	78	92	240	29.90
MK-TOL-84016M-08	8	22	78	100	240	29.90
MK-TOL-84016M-09	9	22	78	108	240	29.90
MK-TOL-84016M-10	10	22	78	114	240	29.90
MK-TOL-84016M-11	11	22	78	120	240	29.90
MK-TOL-84016M-12	12	22	78	132	120	29.90
MK-TOL-84016M-13	13	22	78	143	120	29.90
MK-TOL-84016M-14	14	25	78	155	120	29.90
MK-TOL-84016M-15	15	25	78	170	120	33.30
MK-TOL-84016M-16	16	25	78	180	120	33.30
MK-TOL-84016M-17	17	25	78	191	120	35.40
MK-TOL-84016M-18	18	25	78	202	120	37.80
MK-TOL-84016M-19	19	25	78	216	120	37.80
MK-TOL-84016M-21	21	25	78	250	120	39.10

MK-TOL-84300M
DEEP IMPACT SOCKET



- High grade chrome molybdenum steel with proper heat treatment for extra durability and strength
- Phosphatised finish for extra rust resistance
- Side locking hole

Item Code	84300M (mm)	D1 (mm)	D2 (mm)	L (mm)		Qty/Ctn	Price
MK-TOL-84300M-08	8	14	25	80	120	100	26.60
MK-TOL-84300M-09	9	15	25	80	125	100	26.60
MK-TOL-84300M-10	10	17	25	80	140	100	26.60
MK-TOL-84300M-11	11	18	25	80	145	100	26.60
MK-TOL-84300M-12	12	19	25	80	157	100	26.60
MK-TOL-84300M-13	13	20	25	80	157	100	26.60
MK-TOL-84300M-14	14	22	30	80	172	100	26.60
MK-TOL-84300M-15	15	23	30	80	230	80	26.60
MK-TOL-84300M-16	16	24	30	80	230	80	26.60
MK-TOL-84300M-17	17	26	30	80	240	80	27.90
MK-TOL-84300M-18	18	27	30	80	255	80	29.50
MK-TOL-84300M-19	19	28	30	80	255	80	30.90
MK-TOL-84300M-20	20	29	30	80	255	80	31.90
MK-TOL-84300M-21	21	30	30	80	255	80	31.90
MK-TOL-84300M-22	22	32	30	80	296	60	35.80
MK-TOL-84300M-23	23	33	30	80	300	60	38.60
MK-TOL-84300M-24	24	34	30	80	308	60	38.60
MK-TOL-84300M-25	25	36	30	80	325	60	43.90
MK-TOL-84300M-26	26	37	30	80	344	40	43.90
MK-TOL-84300M-27	27	38	30	80	356	40	46.40
MK-TOL-84300M-28	28	41	30	80	415	40	52.90
MK-TOL-84300M-29	29	41	30	80	415	40	52.90
MK-TOL-84300M-30	30	42	30	80	420	40	56.90
MK-TOL-84300M-32	32	44	30	80	430	40	61.00

MK-TOL-84200
IMPACT
UNIVERSAL JOINT



1/2" L=70mm =150g



- High grade chrome molybdenum steel with proper heat treatment for extra durability and strength
- Phosphatised finish for extra rust resistance
- Steel ball retainer on male end
- Flexing ability for greater access around obstructions
- Precision cold formed for exact, consistent dimensions and greater strength

ITEM CODE	DESCRIPTION	QTY/CTN	PRICE
MK-TOL-84200-70	1/2" Impact Iniversal Joint	100	71.10

MK-TOL-84304M
1/2"Dr. SUPER THIN WALL
DEEP IMPACT SOCKET



"FOR CAR TIRE REPAIR"

- High grade chrome molybdenum steel with proper heat treatment for extra durability and strength
- Phosphatised finish for extra rust resistance
- Super thin wall design allow easy access to restricted space especially wheel nut
- Ideal for automotive tire repair

Item Code	84304M (mm)	D (mm)	L (mm)		Qty/Ctn	Price
MK-TOL-84304M-17	17	24	80	235	100	25.20
MK-TOL-84304M-19	19	26	80	240	100	27.50
MK-TOL-84304M-21	21	28	80	250	80	27.50

MK-TOL-84400M **IMPACT SOCKET**

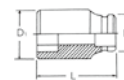

- High grade chrome molybdenum steel with proper heat treatment for extra durability and strength
- Phosphatised finish for extra rust resistance
- Side locking hole

Item Code	84400M (mm)	D1 (mm)	D2 (mm)	L (mm)		Qty/Ctn	Price
MK-TOL-84400M-08	8	14	25	38	76	200	13.40
MK-TOL-84400M-09	9	15	25	38	76	200	13.40
MK-TOL-84400M-10	10	17	25	38	76	200	13.40
MK-TOL-84400M-11	11	18	25	38	76	200	13.40
MK-TOL-84400M-12	12	19	25	38	76	200	13.40
MK-TOL-84400M-13	13	20	25	38	76	200	13.40
MK-TOL-84400M-14	14	22	25	38	77	200	15.90
MK-TOL-84400M-15	15	23	30	38	115	180	15.90
MK-TOL-84400M-16	16	24	30	38	115	180	15.90
MK-TOL-84400M-17	17	26	30	38	115	180	15.90
MK-TOL-84400M-18	18	27	30	38	115	180	15.90
MK-TOL-84400M-19	19	28	30	38	120	180	15.90
MK-TOL-84400M-20	20	29	30	38	120	180	16.70
MK-TOL-84400M-21	21	30	30	40	125	180	16.70
MK-TOL-84400M-22	22	32	30	40	143	100	17.20
MK-TOL-84400M-23	23	33	30	40	143	150	18.10
MK-TOL-84400M-24	24	34	30	42	155	150	19.10
MK-TOL-84400M-25	25	36	30	42	170	120	24.20
MK-TOL-84400M-26	26	37	30	42	178	100	24.20
MK-TOL-84400M-27	27	38	30	44	180	100	24.20
MK-TOL-84400M-28	28	41	30	44	195	100	28.40
MK-TOL-84400M-29	29	41	30	44	195	100	28.40
MK-TOL-84400M-30	30	42	30	44	203	100	29.50
MK-TOL-84400M-32	32	44	30	44	210	60	32.20



MK-TOL-84404M
1/2"Dr. SUPER THIN WALL
IMPACT SOCKET



- High grade chrome molybdenum steel with proper heat treatment for extra durability and strength
- Phosphatised finish for extra rust resistance
- Super thin wall design allow easy access to restricted space especially wheel nut
- Ideal for automotive tire repair

Item Code	84404M (mm)	D (mm)	L (mm)	 g	Qty/Ctn	Price
MK-TOL-84404M-17	17	24	38	105	200	16.00
MK-TOL-84404M-19	19	26	38	115	180	16.00
MK-TOL-84404M-21	21	28	40	120	180	16.70

MK-TOL-84800
IMPACT EXTENSION BAR*



1/2"



- High grade chrome molybdenum steel with proper heat treatment for extra durability and strength
- Phosphatised finish for extra rust resistance

ITEM CODE	DESCRIPTION	MM	INCH		QTY/CTN	PRICE
MK-TOL-84800-075	1/2" Impact Extension Bar	75	3"	170	120	30.50
MK-TOL-84800-250	1/2" Impact Extension Bar	250	10"	440	50	72.20

MK-TOL-86200
IMPACT UNIVERSAL JOINT

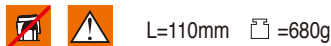

3/4"



- High grade chrome molybdenum steel with proper heat treatment for extra durability and strength
- Phosphatised finish for extra rust resistance
- Steel ball retainer on male end
- Flexing ability for greater access around obstructions
- Precision cold formed for exact, consistent dimensions and greater strength

ITEM CODE	DESCRIPTION	QTY/CTN	PRICE
MK-TOL-86200-110	3/4" Impact Universal Joint	20	177.20

MK-TOL-84410 1/2"Dr. IMPACT E-STAR SOCKET



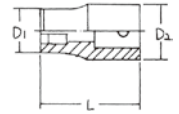

"FOR EXTERNAL STAR SCREW"





- High grade chrome molybdenum steel with proper heat treatment for extra durability and strength
- Phosphatised finish for extra rust resistance
- For external star screw uses

Item Code	84410	D1	D2	L	 g	Qty/Ctn	Price
MK-TOL-84410-E10	E10	15	25	38	85	200	16.90
MK-TOL-84410-E11	E11	16.5	25	38	85	200	16.90
MK-TOL-84410-E12	E12	16	25	38	85	200	16.90
MK-TOL-84410-E14	E14	18.5	25	38	85	200	16.90
MK-TOL-84410-E16	E16	20	25	38	85	200	16.90
MK-TOL-84410-E18	E18	22	25	38	85	200	16.90
MK-TOL-84410-E20	E20	25	30	38	130	200	21.20
MK-TOL-84410-E22	E22	26.5	30	45	160	120	21.20
MK-TOL-84410-E24	E24	28	30	45	160	120	21.20

MK-TOL-84804
IMPACT ADAPTOR

 1/2"x3/8" 
L = 38mm,  =70g

MK-TOL-84805
IMPACT ADAPTOR

 1/2"x3/4" 
L = 42mm,  =110g



• Max permissible torsion= 202Nm.

- High grade chrome molybdenum steel with proper heat treatment for extra durability and strength
- Phosphatised finish for extra rust resistance

ITEM CODE	DESCRIPTION	QTY/CTN	PRICE
MK-TOL-84804-1/2x3/8	1/2" Impact Adaptor	200	20.60
MK-TOL-84805-1/2x3/4	1/2" Impact Adaptor	120	28.00

MK-TOL-86300M DEEP IMPACT SOCKET



3/4"

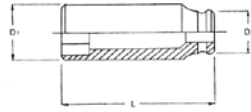

- High grade chrome molybdenum steel with proper heat treatment for extra durability and strength
- Phosphatised finish for extra rust resistance
- Side locking hole

Item Code	86300M (mm)	D1 (mm)	D2 (mm)	L (mm)	g	Qty/Ctn	Price
MK-TOL-86300M-17	17	29	38	90	500	30	77.10
MK-TOL-86300M-18	18	30	38	90	500	30	77.10
MK-TOL-86300M-19	19	32	38	90	500	30	77.10
MK-TOL-86300M-20	20	33	38	90	500	30	77.10
MK-TOL-86300M-21	21	34	38	90	510	30	77.10
MK-TOL-86300M-22	22	36	40	90	530	30	77.10
MK-TOL-86300M-23	23	37	40	90	540	30	77.10
MK-TOL-86300M-24	24	38	40	90	540	30	77.10
MK-TOL-86300M-25	25	40	40	90	570	30	77.10
MK-TOL-86300M-26	26	41	41	90	620	30	77.10
MK-TOL-86300M-27	27	42	42	90	690	30	77.10
MK-TOL-86300M-28	28	44	44	90	720	30	84.30
MK-TOL-86300M-29	29	45	44	90	750	24	84.30
MK-TOL-86300M-30	30	46	44	90	760	24	89.20
MK-TOL-86300M-32	32	48	44	90	790	24	91.70
MK-TOL-86300M-33	33	50	44	90	820	24	94.30
MK-TOL-86300M-34	34	51	44	90	850	24	98.90
MK-TOL-86300M-35	35	52	44	90	880	24	103.50
MK-TOL-86300M-36	36	53	44	90	880	24	108.50
MK-TOL-86300M-38	38	56	44	90	900	24	111.00
MK-TOL-86300M-40	40	59	44	90	960	24	130.40
MK-TOL-86300M-41	41	60	44	90	1000	24	148.60
MK-TOL-86300M-42	42	61	44	90	1050	18	159.70
MK-TOL-86300M-43	43	62	44	90	1100	18	159.70
MK-TOL-86300M-45	45	65	44	95	1200	18	170.90
MK-TOL-86300M-46	46	66	44	95	1200	18	194.60
MK-TOL-86300M-48	48	68	44	100	1300	18	199.00
MK-TOL-86300M-50	50	71	44	100	1300	12	203.10

MK-TOL-86800 IMPACT EXTENSION BAR

3/4"



- High grade chrome molybdenum steel with proper heat treatment for extra durability and strength
- Phosphatised finish for extra rust resistance

ITEM CODE	DESCRIPTION	MM	INCH	g	QTY/CTN	PRICE
MK-TOL-86800-100	3/4" Impact Extension Bar	100	4"	600	36	87.10
MK-TOL-86800-150	3/4" Impact Extension Bar	150	6"	700	24	109.20
MK-TOL-86800-200	3/4" Impact Extension Bar	200	8"	880	18	119.50
MK-TOL-86800-250	3/4" Impact Extension Bar	250	10"	1060	16	125.50

MK-TOL-86400 IMPACT SOCKET



3/4"

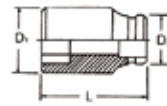

- High grade chrome molybdenum steel with proper heat treatment for extra durability and strength
- Phosphatised finish for extra rust resistance
- Side locking hole

Item Code	86400M (mm)	D1 (mm)	D2 (mm)	L (mm)	g	Qty/Ctn	Price
MK-TOL-86400-17	17	29	38	51	300	48	38.50
MK-TOL-86400-18	18	30	38	51	300	48	38.50
MK-TOL-86400-19	19	32	38	51	310	48	38.50
MK-TOL-86400-20	20	33	38	51	310	48	38.50
MK-TOL-86400-21	21	34	38	51	310	48	38.50
MK-TOL-86400-22	22	36	40	51	320	48	38.50
MK-TOL-86400-23	23	37	40	51	330	48	38.50
MK-TOL-86400-24	24	38	40	51	330	48	39.30
MK-TOL-86400-25	25	40	40	54	340	48	39.30
MK-TOL-86400-26	26	41	41	54	350	48	39.30
MK-TOL-86400-27	27	42	42	54	360	48	39.30
MK-TOL-86400-28	28	44	44	54	380	48	41.70
MK-TOL-86400-29	29	45	44	54	400	36	41.70
MK-TOL-86400-30	30	46	44	54	430	36	43.70
MK-TOL-86400-31	31	47	44	54	450	36	52.00
MK-TOL-86400-32	32	48	44	57	470	36	52.00
MK-TOL-86400-33	33	50	44	57	480	36	52.00
MK-TOL-86400-34	34	51	44	57	500	36	57.00
MK-TOL-86400-35	35	52	44	57	520	36	57.00
MK-TOL-86400-36	36	53	44	57	540	24	64.50
MK-TOL-86400-38	38	56	44	57	580	24	66.20
MK-TOL-86400-39	39	58	44	58	610	24	77.30
MK-TOL-86400-40	40	58	44	58	610	24	77.30
MK-TOL-86400-41	41	60	44	58	620	24	77.30
MK-TOL-86400-42	42	62	44	60	650	24	93.80
MK-TOL-86400-43	43	62	44	60	650	24	93.80
MK-TOL-86400-44	44	65	44	63	740	24	100.80
MK-TOL-86400-45	45	65	44	63	740	24	100.80
MK-TOL-86400-46	46	66	44	63	760	24	105.70
MK-TOL-86400-47	47	67	44	63	800	24	110.40
MK-TOL-86400-48	48	68	44	65	800	24	110.40
MK-TOL-86400-50	50	71	44	58	850	12	115.30
MK-TOL-86400-51	51	72	44	68	890	12	157.50
MK-TOL-86400-52	52	73	54	70	900	12	157.50
MK-TOL-86400-54	54	76	54	73	950	12	157.50
MK-TOL-86400-55	55	77	54	73	1100	12	157.50
MK-TOL-86400-57	57	80	54	73	1200	12	157.50
MK-TOL-86400-58	58	81	54	73	1300	12	157.50
MK-TOL-86400-59	59	82	60	73	1400	12	159.50
MK-TOL-86400-60	60	83	60	80	1500	12	161.20
MK-TOL-86400-63	63	87	60	80	1650	12	185.50
MK-TOL-86400-65	65	90	60	85	1800	12	233.50
MK-TOL-86400-70	70	96	60	90	2000	12	250.00

MK-TOL-86804 IMPACT ADAPTOR

3/4"x1/2"
L = 53mm, g=240g

MK-TOL-86805 IMPACT ADAPTOR

3/4"x1"
L = 65mm, g=320g



- Max permissible torsion= 512Nm.

- High grade chrome molybdenum steel with proper heat treatment for extra durability and strength
- Phosphatised finish for extra rust resistance

ITEM CODE	DESCRIPTION	QTY/CTN	PRICE
MK-TOL-86804-3/4x1/2	3/4" Impact Adaptor	60	58.10
MK-TOL-86805-3/4x1	3/4" Impact Adaptor	36	66.10



MK-TOL-88200 IMPACT UNIVERSAL JOINT



L=130mm =1150g

1"



- High grade chrome molybdenum steel with proper heat treatment for extra durability and strength
- Phosphatised finish for extra rust resistance
- Steel ball retainer on male end
- Flexing ability for greater access around obstructions
- Precision cold formed for exact, consistent dimensions and greater strength

ITEM CODE	DESCRIPTION	QTY/CTN	PRICE
MK-TOL-88200-130	1" Impact Universal Joint	20	296.90

MK-TOL-88305M 4-POINT, BUDD WHEEL DEEP IMPACT SOCKET



1"

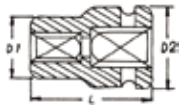

- High grade chrome molybdenum steel with proper heat treatment for extra durability and strength
- Phosphatised finish for extra rust resistance
- Super thin wall design allow easy access to restricted space especially wheel nut
- Ideal for automotive tire repair

Item Code	Size (mm)	D1 mm	D2 mm	L mm	g	Qty/Ctn	Price
MK-TOL-88305M-17	17	40	50	90	760	24	112.00
MK-TOL-88305M-19	19	43	50	90	800	24	112.00
MK-TOL-88305M-21	21	45	50	90	900	24	112.00
MK-TOL-88305M-22	22	45	50	90	900	24	112.00

MK-TOL-88308M 1"Dr. DUAL OPENING - BUDD WHEEL IMPACT SOCKET (STREAMLINE)



1"

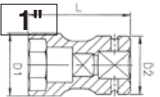

- High grade chrome molybdenum steel with proper heat treatment for extra durability and strength
- Phosphatised finish for extra rust resistance
- Double opening: 17 to 21 square threads studs onto wheel, 32 TO 41 hex tightens lug nuts.

Item Code	Size (mm)	D1 mm	D2 mm	L mm	g	Qty/Ctn	Price
MK-TOL-88308M-3217	32x17	50	54	95	840	18	157.20
MK-TOL-88308M-3820	38x20	56	54	95	965	18	164.90
MK-TOL-88308M-4120	41x20	58	54	95	1010	18	164.90
MK-TOL-88308M-4121	41x21	58	54	95	990	18	164.90

MK-TOL-88304M 1" Dr. THIN WALL - DEEP IMPACT SOCKET

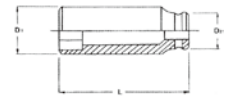

- High grade chrome molybdenum steel with proper heat treatment for extra durability and strength
- Phosphatised finish for extra rust resistance
- Super thin wall design allow easy access to restricted space especially wheel nut
- Ideal for automotive tire repair

Item Code	88304M (mm)	D1 mm	D2 mm	L mm	g	Qty/Ctn	Price
MK-TOL-88304M-24	24	38	50	80	580	20	110.40
MK-TOL-88304M-27	27	41	50	80	580	20	110.40
MK-TOL-88304M-30	30	45	50	80	620	20	110.40
MK-TOL-88304M-32	32	48	52	80	640	20	110.40
MK-TOL-88304M-33	33	49	52	80	650	10	121.00
MK-TOL-88304M-34	34	50	52	80	660	10	121.00
MK-TOL-88304M-35	35	51	52	80	670	10	121.00
MK-TOL-88304M-36	36	53	52	80	690	10	121.00
MK-TOL-88304M-38	38	55	52	80	710	10	132.10
MK-TOL-88304M-41	41	58	52	80	720	10	144.00

MK-TOL-88306M 1" Dr. INNER NUT - FOUR POINT, BUDD WHEEL IMPACT SOCKET

1"

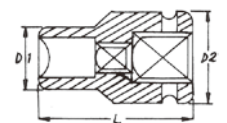

- High grade chrome molybdenum steel with proper heat treatment for extra durability and strength
- Phosphatised finish for extra rust resistance
- For rugged use when working on front and rear axle wheel

Item Code	Size (mm)	D1 mm	D2 mm	L mm	g	Qty/Ctn	Price
MK-TOL-88306M-17	17	40	50	76	660	24	144.00
MK-TOL-88306M-19	19	43	50	76	690	24	144.00
MK-TOL-88306M-20	20	45	50	76	700	24	144.00
MK-TOL-88306M-21	21	45	50	76	690	24	144.00
MK-TOL-88306M-22	22	45	50	76	680	24	144.00



MK-TOL-88400M IMPACT SOCKET

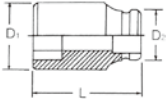

- High grade chrome molybdenum steel with proper heat treatment for extra durability and strength
- Phosphatised finish for extra rust resistance
- Side locking hole

Item Code	Size (mm)	D1 (mm)	D2 (mm)	L (mm)	Weight (g)	Qty/Ctn	Price
MK-TOL-88400M-17	17	27	38	51	270	24	87.00
MK-TOL-88400M-19	19	29	38	51	280	24	87.00
MK-TOL-88400M-21	21	38	50	60	550	24	87.00
MK-TOL-88400M-22	22	39	50	60	560	24	87.00
MK-TOL-88400M-23	23	40	50	60	560	24	87.00
MK-TOL-88400M-24	24	41	50	60	570	24	87.00
MK-TOL-88400M-25	25	43	50	60	570	24	87.00
MK-TOL-88400M-26	26	44	50	60	580	24	87.00
MK-TOL-88400M-27	27	45	50	60	580	24	87.00
MK-TOL-88400M-28	28	46	50	60	590	24	87.00
MK-TOL-88400M-29	29	48	50	60	600	24	87.00
MK-TOL-88400M-30	30	49	50	62	620	24	94.70
MK-TOL-88400M-32	32	52	52	63	660	24	94.70
MK-TOL-88400M-33	33	53	53	63	680	24	94.70
MK-TOL-88400M-34	34	54	54	63	710	24	94.70
MK-TOL-88400M-35	35	55	52	63	710	24	100.10
MK-TOL-88400M-36	36	56	53	67	730	24	103.60
MK-TOL-88400M-38	38	59	54	67	740	24	110.40
MK-TOL-88400M-40	40	61	54	67	750	24	120.50
MK-TOL-88400M-41	41	63	54	70	930	24	127.70
MK-TOL-88400M-43	43	65	54	70	980	16	138.00
MK-TOL-88400M-46	46	69	54	76	1210	16	157.70
MK-TOL-88400M-48	48	71	54	76	1260	16	173.90
MK-TOL-88400M-50	50	74	54	82	1370	12	186.40
MK-TOL-88400M-52	52	75	54	82	1430	12	198.70
MK-TOL-88400M-54	54	79	54	82	1550	12	211.10
MK-TOL-88400M-55	55	80	55	87	1620	12	235.30
MK-TOL-88400M-57	57	83	57	87	1670	8	235.30
MK-TOL-88400M-58	58	84	57	87	1750	8	248.40
MK-TOL-88400M-59	59	85	57	87	1800	8	282.20
MK-TOL-88400M-60	60	86	60	91	1900	8	295.70
MK-TOL-88400M-63	63	90	60	91	2000	8	319.40
MK-TOL-88400M-65	65	93	65	95	2400	8	350.40
MK-TOL-88400M-70	70	99	70	100	2500	8	460.20
MK-TOL-88400M-75	75	103	70	105	2900	6	595.20
MK-TOL-88400M-80	80	111	80	105	2900	6	718.80
MK-TOL-88400M-85	85	118	86	110	3200	6	853.30
MK-TOL-88400M-90	90	124	86	110	3800	6	1,010.60

MK-TOL-88800 IMPACT EXTENSION BAR



1"



- High grade chrome molybdenum steel with proper heat treatment for extra durability and strength
- Phosphatised finish for extra rust resistance

ITEM CODE	DESCRIPTION	MM	INCH	Weight (g)	CTN/QT	PRICE
MK-TOL-88800-150	1" Impact Extension Bar	150	6"	1170	16	208.10
MK-TOL-88800-200	1" Impact Extension Bar	200	8"	1520	12	236.00
MK-TOL-88800-250	1" Impact Extension Bar	250	10"	1880	8	319.80

MK-TOL-88405M 4-POINT, BUDD WHEEL DEEP IMPACT SOCKET

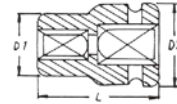

- High grade chrome molybdenum steel with proper heat treatment for extra durability and strength
- Phosphatised finish for extra rust resistance
- For rugged use when working on front and rear axle wheel

Item Code	Size (mm)	D1 mm	D2 mm	L mm	Weight (g)	Qty/Ctn	Price
MK-TOL-88405M-17	17	41	50	58	500	36	126.00
MK-TOL-88405M-19	19	43	50	58	520	36	126.00
MK-TOL-88405M-20	20	42	50	58	530	36	126.00
MK-TOL-88405M-21	21	45	50	58	530	36	126.00

MK-TOL-88804 IMPACT ADAPTOR

1"x3/4" L = 70mm, Weight=540g

MK-TOL-88805 IMPACT ADAPTOR

1"x1-1/2" L = 80mm, Weight=720g



- Max permissible torsion= 1412Nm.

- High grade chrome molybdenum steel with proper heat treatment for extra durability and strength
- Phosphatised finish for extra rust resistance

ITEM CODE	DESCRIPTION	QTY/CTN	PRICE
MK-TOL-88804-1x3/4	1" Impact Adaptor	36	85.70
MK-TOL-88805-1x1-1/2	1" Impact Adaptor	36	176.60

MK-TOL-84483 3PCS WHEEL IMPACT SOCKET SET



COLOR	SIZE (mm)	D1 (mm)	D2 (mm)	LENGTH (mm)
Blue	17	27	30	85
Yellow	19	29	30	85
Red	21	31	30	85

- High grade chrome molybdenum steel with proper heat treatment for extra durability and strength
- Phosphatised finish for extra rust resistance
- Plastic cover to protect aluminium alloy wheel
- Features colour for rapid size identification
- Ideal for automotive tire repair

ITEM CODE	DESCRIPTION	QTY/CTN	PRICE
MK-TOL-84483	3 pcs Wheel Impact Socket Set	20	140.70



MK-TOL-84612 12PCS 1/2" DR. IMPACT SOCKET SET

- High grade chrome molybdenum steel with proper heat treatment for extra durability and strength
- Phosphatised finish for extra rust resistance
- Plastic cover to protect aluminium alloy wheel
- Features colour for rapid size identification
- Ideal for automotive tire repair



MK-TOL-84618 18PCS 1/2" DR. DEEP IMPACT SOCKET SET



- High grade chrome molybdenum steel with proper heat treatment for extra durability and strength
- Phosphatised finish for extra rust resistance
- Ideal for automotive workshop and truck repair

84612 (12pcs)
Alloy Wheel Impact Socket: 17,19,21mm(CR-MO)
Impact socket: 10,12,13,14,17,19,21,24,27mm(CR-MO)

ITEM CODE	DESCRIPTION	QTY/CTN	PRICE
MK-TOL-84612	12 pcs 1/2" Dr. Impact Socket Set	10	178.00

84618 (18pcs)
Set Comprises:- 12 PCS Sockets
- 10, 12, 13, 15, 16, 17, 18, 19, 21, 22, 24, 27mm (CR-MO)
1 PC - 125mm Ext.Bar
1 PC - 250mm Ext.Bar
1 PC - Universal Joint
1 PC - Quick Release Ratchet
1 PC - Flexible Handle
1 PC - Sliding "T" Handle
Metal Case

ITEM CODE	DESCRIPTION	QTY/CTN	PRICE
MK-TOL-84618	18 pcs 1/2" Dr. Deep Impact Socket Set	10	555.00

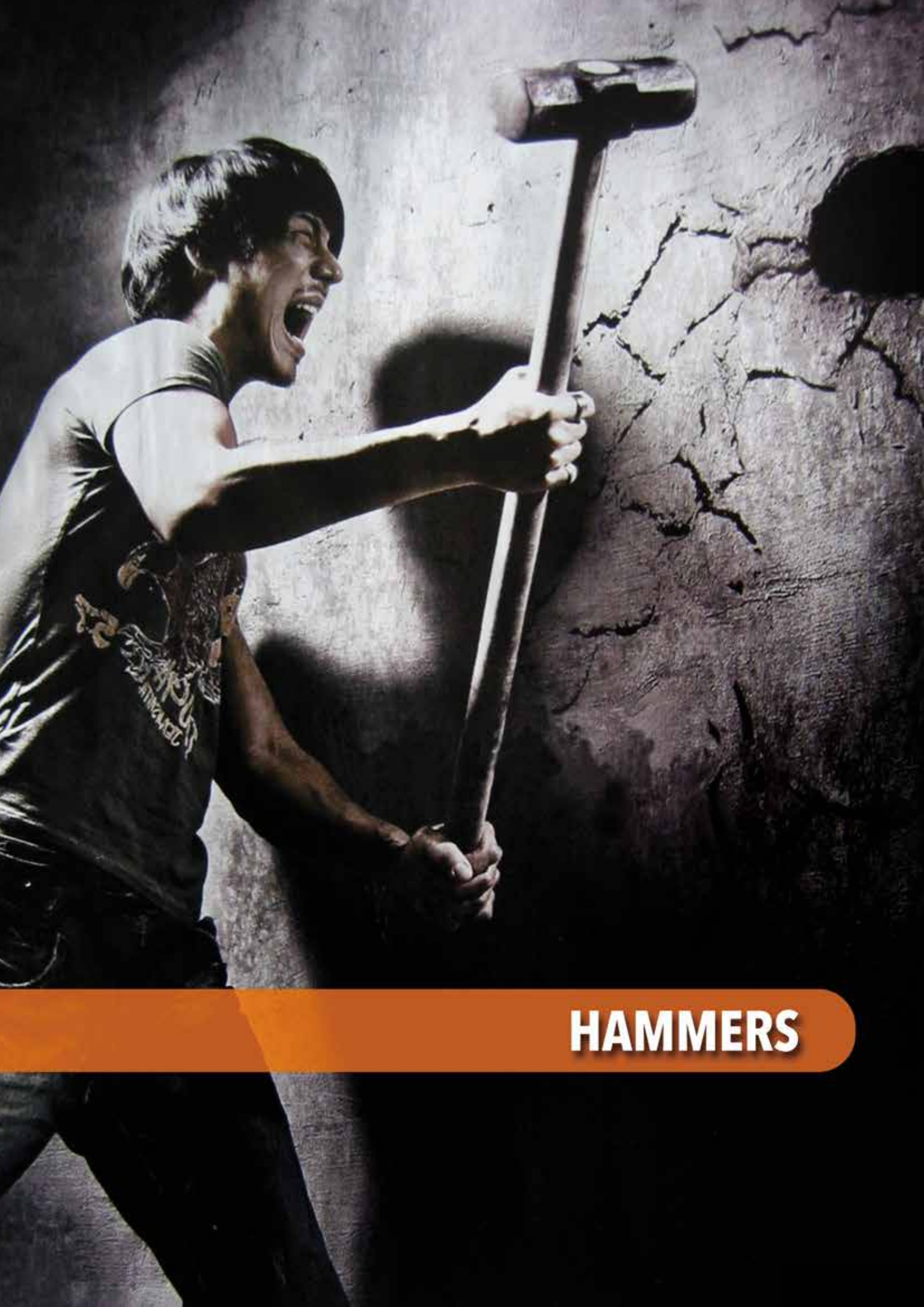

HAMMERS

Hammers

Safety Uses

- Wear gloves and eye protection.
- Do not use suspect tools such as hammers with chipped heads, insecure or cracked handles, excessively mushroomed chisel or punch ends. Check handle fit before use.
- Hammering may generate sparks. Do not use hammers in a fire-risk area.
- Rule of thumb: hammer head should have a diameter about 10 mm larger than the surface to be struck. Avoid hitting with the edge of the hammer.
- Always wear safety glasses to protect the eyes.
- Never strike two hammers, one against the other.
- Never strike anything with the side of the hammer.
- Select the hammer that will hit the chisel or pin as follows; the impact face shall have a diameter 10mm bigger than the face to hit.
- Always strike the hammer perpendicularly to the surface or work tool.
- Never use a soft faced hammer or wood hammer to nail or strike metallic pins.
- Avoid striking equally hard surfaces. Do not use a hammer on surfaces exceeding 46HRc. Use a mallet instead.
- Select chisels and punches fitted with a guard for increased safety and comfort.
- Do not use punches for leverage.



- Never "hard on hard"
- Check tool condition before use

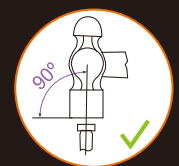
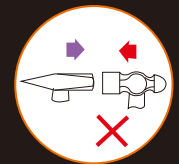

- Never use tools with ill-fitting or damaged handles

MK-TOL-2003 STEEL HANDLE CLAW HAMMER



- High grade carbon steel hardened and tempered for extra durability and strength
- Ergonomic deluxe rubber grip with steel handle provide comfortable uses
- For pounding nails into or extracting nails from

ITEM CODE	HEAD WGT	QTY/CTN	PRICE
MK-TOL-2003	16 oz	36	36.80

MK-TOL-2006 FIBERGLASS HANDLE CLAW HAMMER



- High grade carbon steel hardened and tempered for extra durability and strength
- Ergonomic deluxe rubber grip with fiberglass handle provide comfortable uses
- For pounding nails into or extracting nails from

ITEM CODE	HEAD WGT	QTY/CTN	PRICE
MK-TOL-2006	27 mm	36	30.50

MK-TOL-2008 FIBERGLASS HANDLE BALL PEIN HAMMER



- High grade carbon steel hardened and tempered for extra durability and strength
- Ergonomic deluxe rubber grip with fiberglass handle provide comfortable uses
- For metal working such as striking, punches and chisels

ITEM CODE	HEAD WGT	QTY/CTN	PRICE
MK-TOL-2008-1	1 lb	36	34.00
MK-TOL-2008-1.5	1 1/2 lb	24	37.00
MK-TOL-2008-2	2 lb	24	50.00
MK-TOL-2008-2.5	2 1/2 lb	12	59.00

MK-TOL-2014 FIBERGLASS HANDLE ENGINEER'S CROSS PEIN HAMMER



- High grade carbon steel hardened and tempered for extra durability and strength
- Ergonomic deluxe rubber grip with fiberglass handle provide comfortable uses
- Ideal for metal fabrication, especially when working with angled sheet metal.

ITEM CODE	Size (mm)	QTY/CTN	PRICE
MK-TOL-2014-16	16 mm	60	22.00
MK-TOL-2014-18	18 mm	36	25.00
MK-TOL-2014-20	20 mm	48	28.00

MK-TOL-2004 FIBERGLASS HANDLE CLAW HAMMER



- High grade carbon steel hardened and tempered for extra durability and strength
- Ergonomic deluxe rubber grip with fiberglass handle provide comfortable uses
- For pounding nails into or extracting nails from

ITEM CODE	HEAD WGT	QTY/CTN	PRICE
MK-TOL-2004	16 oz	36	38.00

MK-TOL-2007 WOOD HANDLE BALL PEIN HAMMER*



- American hickory handle.
- High grade carbon steel hardened and tempered.
- Extra durability and strength.

ITEM CODE	HEAD WGT	QTY/CTN	PRICE
MK-TOL-2007-1.5	1 1/2 lb	24	33.60

MK-TOL-2010 FIBERGLASS HANDLE DOUBLE FACE SLEDGE HAMMER



- High grade carbon steel hardened and tempered for extra durability and strength
- Ergonomic deluxe rubber grip with fiberglass handle provide comfortable uses
- For striking metal, concrete and stone

ITEM CODE	HEAD WGT	QTY/CTN	PRICE
MK-TOL-2010-02	2 lb	24	48.00
MK-TOL-2010-03	3 lb	16	57.00
MK-TOL-2010-04	4 lb	12	69.80

MK-TOL-2015 DEAD BLOW HAMMER



- Solid steel bar shaft and hollow head
- Thousands of steel pellets are included in the polyurethane molded hammer which impact a split second after the hammer face
- Ideal for dislodging stuck parts, pop up small dents, hubcap installation or removal and etc

ITEM CODE	HEAD WGT	L	QTY/CTN	PRICE
MK-TOL-2015-1	1 lb	300	24	41.20
MK-TOL-2015-1.5	1 1/2 lb	300	24	51.10
MK-TOL-2015-2	2 lb	300	24	54.00

MK-TOL-2016 RUBBER Mallet WITH HARD WOOD HANDLE



- Tough rubber head molded to a wood handle
- Rubber head helps minimise marring and surface damage
- Ideal for shifting plasterboard, forcing tight fitting parts together, bending and shape sheet metal and general uses

ITEM CODE	HEAD WGT	L	QTY/CTN	PRICE
MK-TOL-2016-08OZ	8 oz	290	36	18.30
MK-TOL-2016-16OZ	16 oz	380	24	19.70
MK-TOL-2016-24OZ	24 oz	380	24	30.40

MK-TOL-2021 TUBULAR STEEL HANDLE WITH MAGNETIC KARIWAKU HAMMER



One piece steel body



Milled face allow nailing accurately



Magnetic nail holder design allow nailing in higher area

- Built in Magnetic nail holder, allows you to start a nail "hands free"
- Feature with a groove in the head with a small magnet inside to hold nails and useful for nailing in higher areas.
- Ergonomic rubber grip with steel handle provide comfortable uses

ITEM CODE	HEAD WGT	QTY/CTN	PRICE
MK-TOL-2021	13 oz	36	120.00

MK-TOL-2020 CURVED DRAGON HAMMER

The **D**ragon

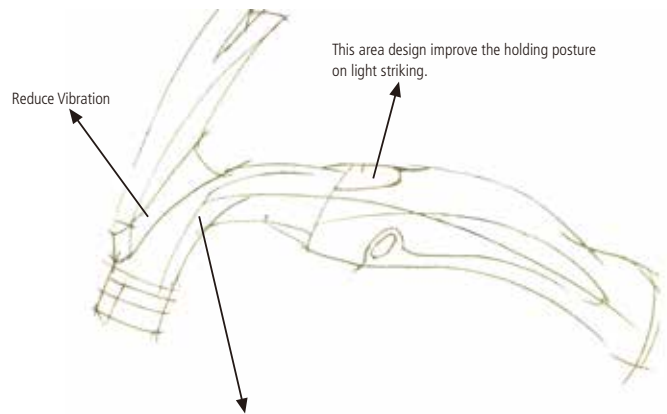

This Dragon hammer design features & advantages:

1. Curve design increases the strike correctness.
2. Break through the traditional T type hammer.
3. Curve design decreases the force to pull the nails for Curved claw.
4. This design is based on Ergonomics which provides safely & comfortably to user.

- High grade cast steel hardened and tempered for extra durability and strength
- Ergonomic design with deluxe rubber grip provide comfortable uses
- Curve design increases the strike correctness and safe energy in pulling out nails from curved claw
- Breakthrough the traditional T hammer
- Feature with anti-vibration design on head

ITEM CODE	HEAD WEIGHT		OVERALL LENGTH MM	INNER	CTN	PRICE
	OZ.	GRAM				
MK-TOL-2020-20OZ	20oz	567gm	320mm	6	24	149.80



PLIERS, NIPPERS AND CUTTER

Pliers Safety Uses

- Keep within cutter capacity (wire diameter and hardness).
- Do not modify or heat tips as this will impair performance.
- Cut at right angles and avoid twisting the wire. Use the throat rather than the tip of cutting edges.
- When fitting circlips, use a tool within the correct range and only compress or expand the clip just enough.
- Lock-grip pliers should not be used as a permanent clamp.
- Components can move due to vibration or shock.
- Wear eye protection, especially when cutting wire and fitting circlips or rivets.
- Always wear safety glasses to protect the eye.
- Never Use pliers as a hammer. It can crack and even break.
- Never expose pliers to excessive heat. It can change the heat treatment applied at the cutting edges and reduce performance.
- Never increase the length of the pliers handle.
- Always ensure pliers are perpendicular to the wire for a quicker and safer operation.
- Do not use cracked insulated grip pliers for electrical lines.
- Oil the joint occasionally.
- When fitting circlips, use tool within the correct range and only compress or expand the clip just enough.
- Lock grip pliers should not be used as a permanent clamp.
- Cut wire back in jaw, Not at tip.
- Wear gloves to protect the hands.
- Place the wire or strip to be cut perpendicularly to the cutting tool.
- Keep the cutting edges oiled.
- Ensure the cutting capacity of the tool is sufficient to cut material required.
- Cover the part of piece that will be cut to avoid it jumping when using a bolt cutter.
- Do not use broken, worn or cracked blades.
- Metal shears are designed for cutting sheet metal and not for wire.
- Do not cut wire with metal shears.
- Keep hands away from the cutting path.



- Never modify the shape of a tool

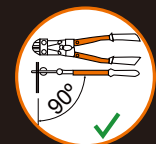



MK-TOL-1501 LINESMAN PLIER



CRV material for extra durability



Ergonomic TPR handle



- Chrome vanadium steel with proper heat treatment for extra durability and strength
- Fine polished for extra rust resistance
- High frequency hardened cutting edge ensure cutting performance
- For cutting medium hard wire, gripping pipes, rods and other component and twisting soft wire application

ITEM CODE	DESCRIPTION	QTY/CTN	PRICE
MK-TOL-1501-06	6" Linesman Plier	60	23.20
MK-TOL-1501-07	7" Linesman Plier	60	25.40
MK-TOL-1501-08	8" Linesman Plier	60	28.50

MK-TOL-1504 LONG NOSE PLIER



CRV material for extra durability



Ergonomic TPR handle



- Ergonomic TPR grip handle provide comfortable uses
- Chrome vanadium steel with proper heat treatment for extra durability and strength
- Fine polished for extra rust resistance
- High frequency hardened cutting edge ensure cutting performance
- For gripping in confined spaces and side cutting medium hard wire

ITEM CODE	DESCRIPTION	QTY/CTN	PRICE
MK-TOL-1504-05	5" Long Nose Plier	60	21.30
MK-TOL-1504-06	6" Long Nose Plier	60	21.30
MK-TOL-1504-08	8" Long Nose Plier	60	25.40

MK-TOL-1505M SLIP-JOINT PLIER



CRV material for extra durability



Non Slip foam grip handle



- Non slip foam grip handle provide comfortable uses
- Chrome vanadium steel with proper heat treatment for extra durability and strength
- Dual position joint allows use across a wide range of diameters
- For gripping pipes, nuts and bolts application

ITEM CODE	DESCRIPTION	QTY/CTN	PRICE
MK-TOL-1505M-06	6" Slip-Joint Plier	60	19.30
MK-TOL-1505M-08	8" Slip-Joint Plier	60	24.40

MK-TOL-1506 WATER PUMP PLIER



CRV material for extra durability



Non Slip foam grip handle



- Non slip foam grip handle provide comfortable uses
- Chrome vanadium steel with proper heat treatment for extra durability and strength
- Fine polished for extra rust resistance
- Groove joint for heavy duty application and efficient work
- For gripping pipes, nuts and bolts application

ITEM CODE	DESCRIPTION	QTY/CTN	PRICE
MK-TOL-1506-08	8" Water Pump Plier	60	30.20
MK-TOL-1506-10	10" Water Pump Plier	60	37.20
MK-TOL-1506-12	12" Water Pump Plier	50	50.20
MK-TOL-1506-16	16" Water Pump Plier	20	117.80

MK-TOL-1508 DIAGONAL PLIER



CRV material for extra durability

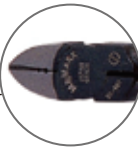

Non Slip foam grip handle



- Non slip foam grip handle provide comfortable uses
- Chrome vanadium steel with proper heat treatment for extra durability and strength
- Fine polished for extra rust resistance
- High frequency hardened cutting edge precision cutting for hard and soft wire
- For cutting medium hard wire application

ITEM CODE	DESCRIPTION	QTY/CTN	PRICE
MK-TOL-1508-06	6" Diagonal Plier	100	30.90

MK-TOL-1511 PVC CUTTER PLIER



CRV material for extra durability



Non Slip foam grip handle



- Non slip foam grip handle provide comfortable uses
- Chrome vanadium steel with proper heat treatment for extra durability and strength
- Fine polished for extra rust resistance
- High frequency hardened cutting edge precision cutting for hard and soft wire
- Heavy duty application

ITEM CODE	DESCRIPTION	QTY/CTN	PRICE
MK-TOL-1511-05	5" PVC Cutter Plier	120	38.30



MK-TOL-1512 FLUSH NIPPER PLIER



- Chrome vanadium steel with proper heat treatment for extra durability and strength
- Fine polished for extra rust resistance
- High frequency hardened cutting edge precision cutting for hard and soft wire
- Japan Type

ITEM CODE	DESCRIPTION	QTY/CTN	PRICE
MK-TOL-1512-5	5" Flush Nipper Plier	200	38.30

MK-TOL-1513 MASONRY PLIER (Mosial Cutter)



- Hand forged, oil hardened steel with proper heat treatment for extra durability and strength
- High frequency hardened cutting edge for hard wire
- Special design for cutting wire not accessible from the side and allows knuckle clearance

ITEM CODE	DESCRIPTION	QTY/CTN	PRICE
MK-TOL-1513-08	8" Masonry Plier (Mosial Cutter)	72	54.20

MK-TOL-1515 SNAP RING PLIER - SS

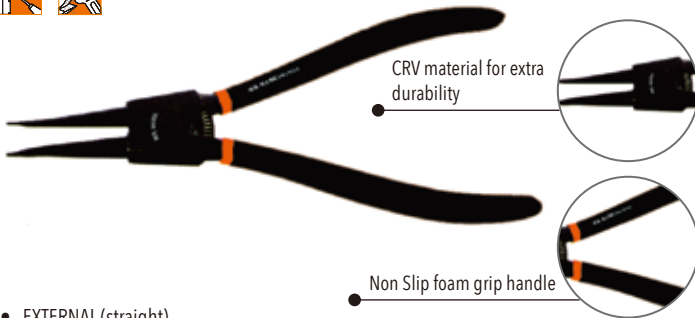

- EXTERNAL (straight)
- Non slip foam grip handle provide comfortable uses
- Chrome vanadium steel with proper heat treatment for extra durability and strength
- Fine polished for extra rust resistance
- Size 0-2 with spiral spring, 3- 4 with leaf spring
- For expanding and fitting external circlips application

ITEM CODE	DESCRIPTION	QTY/CTN	PRICE
MK-TOL-1515-07	7" Snap Ring Plier - SS	100	42.80
MK-TOL-1515-09	9" Snap Ring Plier - SS	100	65.00

MK-TOL-1516 SNAP RING PLIER - SB



- EXTERNAL (90° angled)
- Non slip foam grip handle provide comfortable uses
- Chrome vanadium steel with proper heat treatment for extra durability and strength
- Fine polished for extra rust resistance
- Size 0-2 with spiral spring, 3- 4 with leaf spring
- For expanding and fitting external circlips application

ITEM CODE	DESCRIPTION	QTY/CTN	PRICE
MK-TOL-1516-07	7" Snap Ring Plier - SB	100	42.80
MK-TOL-1516-09	9" Snap Ring Plier - SB	100	65.00

MK-TOL-1517 SNAP RING PLIER - HS



- INTERNAL (straight)
- Non slip foam grip handle provide comfortable uses
- Chrome vanadium steel with proper heat treatment for extra durability and strength
- Fine polished for extra rust resistance
- Size 0-2 with spiral spring, 3- 4 with leaf spring
- For compressing and fitting internal circlips application

ITEM CODE	DESCRIPTION	QTY/CTN	PRICE
MK-TOL-1517-07	7" Snap Ring Plier - HS	100	42.80
MK-TOL-1517-09	9" Snap Ring Plier - HS	100	65.00

MK-TOL-1518 SNAP RING PLIER - HB

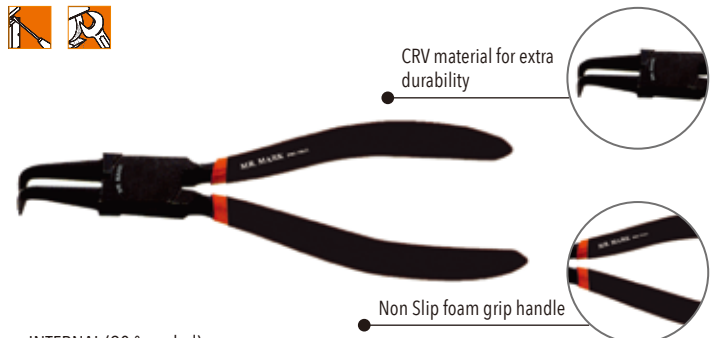

- INTERNAL (90° angled)
- Non slip foam grip handle provide comfortable uses
- Chrome vanadium steel with proper heat treatment for extra durability and strength
- Fine polished for extra rust resistance
- Size 0-2 with spiral spring, 3- 4 with leaf spring
- For compressing and fitting internal circlips application

ITEM CODE	DESCRIPTION	QTY/CTN	PRICE
MK-TOL-1518-07	7" Snap Ring Plier - HB	100	42.80
MK-TOL-1518-09	9" Snap Ring Plier - HB	100	65.00



MK-TOL-1519 CABLE CUTTER



CRV material for extra durability



Non Slip foam grip handle



- Non slip foam grip handle provide comfortable uses
- Chrome vanadium steel with proper heat treatment for extra durability and strength
- Fine polished for extra rust resistance
- Lay joint added strength for heavy duty cutting hard wire application

ITEM CODE	DESCRIPTION	QTY/CTN	PRICE
MK-TOL-1519-06	6" Cable Cutter	120	51.70
MK-TOL-1519-08	8" Cable Cutter	50	65.00
MK-TOL-1519-10	10" Cable Cutter	50	83.40

MK-TOL-1520

AMERICAN TYPE TIN SNIPS CUTTER*



- Rubber grip handle provide comfortable uses
- Chrome vanadium steel with proper heat treatment for extra durability and strength
- High frequency hardened cutting edge ensure cutting performance
- Flat face guides snips along straight line
- Cuts from straight to wide left and wide right curves

ITEM CODE	DESCRIPTION	QTY/CTN	PRICE
MK-TOL-1520-10	10" American Type Tin Snips Cutter	36	79.40

MK-TOL-1521

AVIATION TIN SNIPS LEFT CUT*



- Ergonomic rubber grip handle provide comfortable uses
- Chrome vanadium steel with proper heat treatment for extra durability and strength
- Fine polished for extra rust resistance
- High frequency hardened cutting edge ensure cutting performance
- Used to cut metal for things like duct work.
- Recommended to cut heavy metal to left curve because the blades on left-cutting tin snips blade design

ITEM CODE	DESCRIPTION	QTY/CTN	PRICE
MK-TOL-1521-10	10" Aviation Tin Snips Left Cut	60	46.60

MK-TOL-1522

AVIATION TIN SNIPS RIGHT CUT*



- Ergonomic rubber grip handle provide comfortable uses
- Chrome vanadium steel with proper heat treatment for extra durability and strength
- Fine polished for extra rust resistance
- High frequency hardened cutting edge ensure cutting performance
- Recommended to cut heavy metal to right curve because the blades on right-cutting tin snips blade design

ITEM CODE	DESCRIPTION	QTY/CTN	PRICE
MK-TOL-1522-10	10" Aviation Tin Snips Right Cut	60	46.60

MK-TOL-1523 AVIATION TIN SNIPS STRAIGHT CUT



- Ergonomic rubber grip handle provide comfortable uses
- Chrome vanadium steel with proper heat treatment for extra durability and strength
- Fine polished for extra rust resistance
- High frequency hardened cutting edge ensure cutting performance
- Ideal for cutting low carbon, cold rolled steel sheet and plastic

ITEM CODE	DESCRIPTION	QTY/CTN	PRICE
MK-TOL-1523-10	10" Aviation Tin Snips Straight Cut	60	44.40

MK-TOL-1524 BOLT CUTTER



- Ergonomic rubber grip handle provide comfortable uses
- Chrome vanadium steel with proper heat treatment for extra durability and strength
- Fine polished for extra rust resistance
- High frequency hardened cutting edge ensure cutting performance
- Ideal to cut through bolts, locks, padlocks, chain and wire mesh

ITEM CODE	DESCRIPTION	QTY/CTN	PRICE
MK-TOL-1524-08	8" Bolt Cutter	72	43.10
MK-TOL-1524-12	12" Bolt Cutter	20	87.20
MK-TOL-1524-14	14" Bolt Cutter	20	104.90
MK-TOL-1524-18	18" Bolt Cutter	12	126.20
MK-TOL-1524-24	24" Bolt Cutter	10	172.80
MK-TOL-1524-30	30" Bolt Cutter	6	246.20
MK-TOL-1524-36	36" Bolt Cutter	5	316.50
MK-TOL-1524-42	42" Bolt Cutter	3	512.30



MK-TOL-1525 LONG NOSE LOCKING PLIER



- Chrome vanadium steel with proper heat treatment for extra durability and strength
- Nickel plated finish for extra rust resistance
- Long, straight nose provide easy access in narrow, hard to reach places
- Ideal for tightening, clamping, twisting and turning
- Recommend for precision work and hobbies include convenient wire cutter

ITEM CODE	DESCRIPTION	QTY/CTN	PRICE
MK-TOL-1525-S6.5	6 1/2" Long Nose Locking Plier	120	35.20
MK-TOL-1525-S9	9" Long Nose Locking Plier	72	38.40

MK-TOL-1526 CURVED LOCKING PLIER



- Chrome vanadium steel with proper heat treatment for extra durability and strength
- Nickel plated finish for extra rust resistance
- Guarded releases enables easy opening and accidental release
- For general purpose application

ITEM CODE	DESCRIPTION	QTY/CTN	PRICE
MK-TOL-1526-S05	5" Locking Plier	96	26.60
MK-TOL-1526-S07	7" Locking Plier	60	32.00
MK-TOL-1526-S10	10" Locking Plier	36	34.90

MK-TOL-1527 HEAVY DUTY CURVED JAW LOCKING PLIER



- Chrome vanadium steel with proper heat treatment for extra durability and strength
- Nickel plated finish for extra rust resistance
- Standard curved jaw design applies maximum pressure to all four corners of nuts and bolts head
- Ideal for pipes, fitting nuts and bolts

ITEM CODE	DESCRIPTION	QTY/CTN	PRICE
MK-TOL-1527-S05	5" Heavy Duty Curved Jaw Locking Plier	144	47.70
MK-TOL-1527-S07	7" Heavy Duty Curved Jaw Locking Plier	48	56.20
MK-TOL-1527-S10	10" Heavy Duty Curved Jaw Locking Plier	50	58.20

MK-TOL-1528 HEAVY DUTY STRAIGHT JAW LOCKING PLIER*



- Chrome vanadium steel with proper heat treatment for extra durability and strength
- Nickel plated finish for extra rust resistance
- Standard straight jaw design for a range of applications
- For general purpose application

ITEM CODE	DESCRIPTION	QTY/CTN	PRICE
MK-TOL-1528-S07	7" Heavy Duty Straight Jaw Locking Plier	60	55.10

MK-TOL-1529 DEEP THROAT CLAW-GRIP PLIER*



- Chrome molybdenum steel with proper heat treatment for extra durability and strength
- Nickel plated finish for extra rust resistance
- For gripping sections and angles

ITEM CODE	DESCRIPTION	QTY/CTN	PRICE
MK-TOL-1529-6.5	6-1/2" Deep Throat Claw-Grip Plier	72	62.50

MK-TOL-1530 LOCKING "C" CLAMP PLIER*



- Chrome molybdenum steel with proper heat treatment for extra durability and strength
- Nickel plated finish for extra rust resistance
- For gripping sections and angles 45°

ITEM CODE	DESCRIPTION	QTY/CTN	PRICE
MK-TOL-1530-17.5	17-1/2" Locking "C" Clamp Plier	60	193.30



MK-TOL-1531 LOCKING WELDING CLAMP*



- Chrome vanadium steel with proper heat treatment for extra durability and strength
- Chrome nickel plated finish to resist corrosion
- U shaped jaws provide visibility and working space
- Knurled nut adjusts the jaw opening and pressure
- Quick release level to unlock the jaws
- For welding or holding awkward shapes in place
- Recommend for welding works and fabrication workshop

ITEM CODE	LENGTH (mm)	JAW ADJUSTMENT (mm)	g	QTY/CTN	PRICE
MK-TOL-1531	275mm	0-85mm	715	60	83.10

MK-TOL-1533 PIPE WRENCH



- Easy-spinning lock nut
- Body and moving jaw in carbon steel Enamelled finish articulated cage with a double spring device which grips the pipe immediately, allowing work to continue without interruption
- Quick adjusting jaw ratchets and releases quickly and smoothly
- For turning soft iron pipes and fittings with a rounded surface.

ITEM CODE	DESCRIPTION	QTY/CTN	PRICE
MK-TOL-1533-10	10" Pipe Wrench	30	40.00
MK-TOL-1533-12	12" Pipe Wrench	30	44.00
MK-TOL-1533-14	14" Pipe Wrench	20	59.00
MK-TOL-1533-18	18" Pipe Wrench	10	78.00
MK-TOL-1533-24	24" Pipe Wrench	10	98.00

MK-TOL-1536 5 WAY DELUXE CRIMPING TOOL



- Dipped cushion grips
- Designed to work as bolts cutter, wire cutter and wire stripper and crimper
- Body in black cut sheet steel with burnished finish

ITEM CODE	DESCRIPTION	QTY/CTN	PRICE
MK-TOL-1536-240	240mm 5 Way Deluxe Crimping Tool	100	28.10

MK-TOL-1532 FORGED OIL FILTER WRENCH



- Chrome vanadium steel with proper heat treatment for extra durability and strength
- Easily remove stubborn oil filters
- Spring and cam locking mechanism
- Recommended to most car and trucks as well as holding pipes or objects of irregular shape

ITEM CODE	DESCRIPTION	QTY/CTN	PRICE
MK-TOL-1532-085	85mm Forged Oil Filter Wrench	60	56.50
MK-TOL-1532-102	102mm Forged Oil Filter Wrench	60	64.20

MK-TOL-1534 HEAVY DUTY ADJUSTABLE WRENCH



- Chrome vanadium steel with proper heat treatment for extra durability and strength
- Nickel plated finish for extra rust resistance
- Smooth action precision machined jaws with metric calibration and sliding jaw opened by rotating knurl to the right
- Head set at 15° with scale in millimeters
- For tightening and loosening different sizes of bolts and nuts
- Ideal for plumbing, automotive and general fastening work

ITEM CODE	DESCRIPTION	QTY/CTN	PRICE
MK-TOL-1534-06	6" Heavy Duty Adjustable Wrench	60	26.80
MK-TOL-1534-08	8" Heavy Duty Adjustable Wrench	60	33.00
MK-TOL-1534-10	10" Heavy Duty Adjustable Wrench	60	44.90
MK-TOL-1534-12	12" Heavy Duty Adjustable Wrench	36	64.10
MK-TOL-1534-15	15" Heavy Duty Adjustable Wrench	12	139.30

MK-TOL-1541 P.V.C. PIPE CUTTER



- High frequency hardened cutting edge ensure cutting performance
- Ratchet type model for an effortless progressive cutting action
- This ratchet action PVC pipe cutter makes clean cuts through rubber hoses and PVC pipe up to 1-1/2" in diameter with this razor-shape blade

ITEM CODE	DESCRIPTION	QTY/CTN	PRICE
MK-TOL-1541-1.5	1 1/2" 42mm P.V.C Pipe Cutter	50	63.00



MK-TOL-1542 HAND RIVETER



- Plastic handle provide comfortable uses
- Supplied with three interchangeable nozzles
- Sheet iron body
- For blind rivet 2.4mm to 4.8mm
- Ideal for metal, fabric, leather, plastic and etc

WORKING RANGE

Material Rivet/ Mandrel	Rivet Dia			
	2.4mm 3/32"	3.2mm 1/8"	4.0mm 5/32"	4.8mm 3/16"
Aluminum/ Alumi	○	○	○	○
Aluminum/ Steel	○	○	○	○
Steel/Steel	○	○	○	○
Stainless steel	○	○	○	×

ITEM CODE	DESCRIPTION	QTY/CTN	PRICE
MK-TOL-1542	Hand Riveter	40	44.30

MK-TOL-1549 WIRE STRIPPERS & CUTTERS*



- Cut bolts and screw from size 4-40 to 10-24.
- High quality blade
- 3 times longer life
- Cut and cleanly strips any electrical wire from 10 to 22 gauge.
- Crimps both insulated and non-insulated ignition terminals.
- Tool has black oxide finish for rust resistance.
- Vinyl clad cushion grip handles insulate as well as provide comfort of use.

ITEM CODE	DESCRIPTION	QTY/CTN	PRICE
MK-TOL-1549	Wire Strippers & Cutters	36	24.90

MK-TOL-1559 7 1/2" TOOL SHEARS



- Ergonomic TPR grip handle provide comfortable uses
- SK 5 steel with proper heat treatment for extra durability and strength
- High frequency hardened cutting edge ensure cutting performance
- Featured with steel lock
- Ideal for gardening purpose

ITEM CODE	DESCRIPTION	QTY/CTN	PRICE
MK-TOL-1559	7 1/2" Tool Shears	120	41.70

MK-TOL-1545 END NIPPER*



- High frequency hardened cutting edge ensure cutting performance
- Chrome vanadium steel with proper heat treatment for extra durability and strength
- Ideal to cut nails, wires and staples flush
- Can be used as wire cutters, staple pullers, and flush cutters

ITEM CODE	DESCRIPTION	QTY/CTN	PRICE
MK-TOL-1545	End Nipper (Suitable Size - 7")	60	31.90

MK-TOL-1558 8" GARDEN SHEARS



SK5 Material provides excellent cutting performance



Ergonomic TPR handle provides grip for oily finger



- Ergonomic TPR grip handle provide comfortable uses
- SK 5 steel with proper heat treatment for extra durability and strength
- High frequency hardened cutting edge ensure cutting performance
- Featured with steel lock
- Ideal for gardening purpose

ITEM CODE	DESCRIPTION	QTY/CTN	PRICE
MK-TOL-1558	8" Garden Shears	120	38.60

MK-TOL-9310 2 IN 1 DUAL JAW PRECISION PLIERS



2 in 1 tools



For wire cut



For wire strip

- Ergonomic rubber grip handle provide comfortable uses and high leverage grips
- Different jaws for fast and easy wire cutting and stripping
- Wire stripping jaws grips and strips
- Diagonal jaw cuts wire cleanly
- Spring loaded jaws for easy use

ITEM CODE	DESCRIPTION	QTY/CTN	PRICE
MK-TOL-9310	2 In 1 Dual Jaw Precision Pliers	24	63.60



MK-TOL-9601A
2 IN 1 MULTI-TOOL STRAIGHT & CABLE CUTTER



2 in 1 tools



For cable cut



For straight cut

- Ergonomic rubber grip handle provide comfortable uses and high leverage grips
- Stainless Steel blades with proper heat treatment for extra durability and strength
- Aluminum body
- Swivel Handles to change function

ITEM CODE	DESCRIPTION	QTY/CTN	PRICE
MK-TOL-9601A	2 In 1 Multi-tool Straight & Cable Cutter	24	85.90

MK-TOL-9601B
2 IN 1 MULTI-TOOL WIRE STRIPPER & CABLE CUTTER



2 in 1 tools



For wire strip



For cable cut

- Ergonomic rubber grip handle provide comfortable uses and high leverage grips
- Stainless Steel blades with proper heat treatment for extra durability and strength
- Aluminum body
- Swivel Handles to change function
- For cutting and stripping cable uses

ITEM CODE	DESCRIPTION	QTY/CTN	PRICE
MK-TOL-9601B	2 In 1 Multi-tool Wire Stripper & Cable Cutter	24	85.90

MK-TOL-9301L
2 IN 1 MULTI-TOOL BYPASS PRUNER & FLORAL SHEAR



2 in 1 tools



For pruner shear



For floral shear

- Ergonomic rubber grip handle provide comfortable uses and high leverage grips
- Teflon coated blades resist sticking
- Precision forged blades for clean cuts
- Lightweight and compact
- Spring loaded jaws for easy use

ITEM CODE	DESCRIPTION	QTY/CTN	PRICE
MK-TOL-9301L	2 In 1 Multi-tool Bypass Pruner & Floral Shear	24	62.20

MK-TOL-9710M
ALL PURPOSE UTILITY SHEAR



Jaws open to 1-3/4" for extra big cutting job



Replaceable razor sharp steel blade for clean consistent cut (5blades)

- Ergonomically designed jaw and handle provide powerful cutting angle with less fatigue
- Replaceable razor steel blade for clean consistent cuts
- Jaws open to 1-3/4" for extra big cutting jobs

ITEM CODE	DESCRIPTION	QTY/CTN	PRICE
MK-TOL-9710M	All Purpose Utility Shear	48	77.40



MK-CON-9011 TURBO UTILITY CUTTER (Auto Lock)

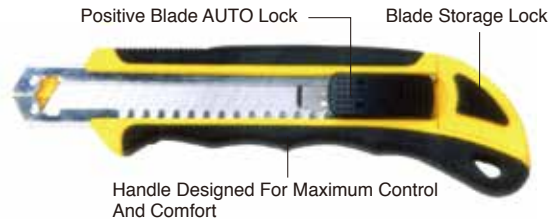

- Heavy-duty tool with automatic locking and skid proof
- Special treatment to make comfortable streamline handle with rubber grip
- 72 snap-off blades included
- Automatic self-loading blades
- Co-molded rubber case
- For general application

Item Code	Spec (mm)	Length (mm)	Qty/Ctn	Price
MK-CON-9011-170	0.5 x 18	170	144	11.80

MK-TOL-SC10 2 INCH MINI SPRING CLAMP



- Constructed of heavy-duty steel for durability and features vinyl tips to protect projects.
- The handles feature small holes to hang clamped objects.
- Up to 2 1/4 in. clamping capacity
- Non-marring vinyl tips protection
- Nickel plated
- Long-lasting tempered steel spring
- Perfect for hobbies and crafts, woodworking, shop, and hundreds of other uses

ITEM CODE	DESCRIPTION	QTY/CTN	PRICE
MK-TOL-SC10	10pcs 2 Inch Mini Spring Clamp	48	17.50

MK-CON-9014 CUTTER BLADE

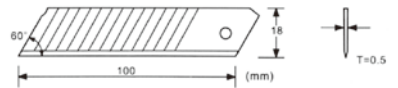

- High quality blade
- 3 times longer life
- 10pcs/ case

ITEM CODE	DESCRIPTION	QTY/CTN	PRICE
MK-CON-9014-180	MK-9014 Cutter Blade	2,000	0.40

MK-TOL-8905L AUTO LOADING UTILITY KNIFE



Cartridge can load up to 6pcs blades



Features with quick release function

- Ergonomically designed jaw and handle provide powerful cutting angle with less fatigue
- Heavy duty die cast body
- Feature with quick release button
- Stores and automatically loads new blades and easy blade removal
- Cartridge hold up to 6pcs blades

ITEM CODE	DESCRIPTION	QTY/CTN	PRICE
MK-TOL-8905L	Auto Loading Utility Knife	36	93.00



SCREWDRIVERS AND BITS

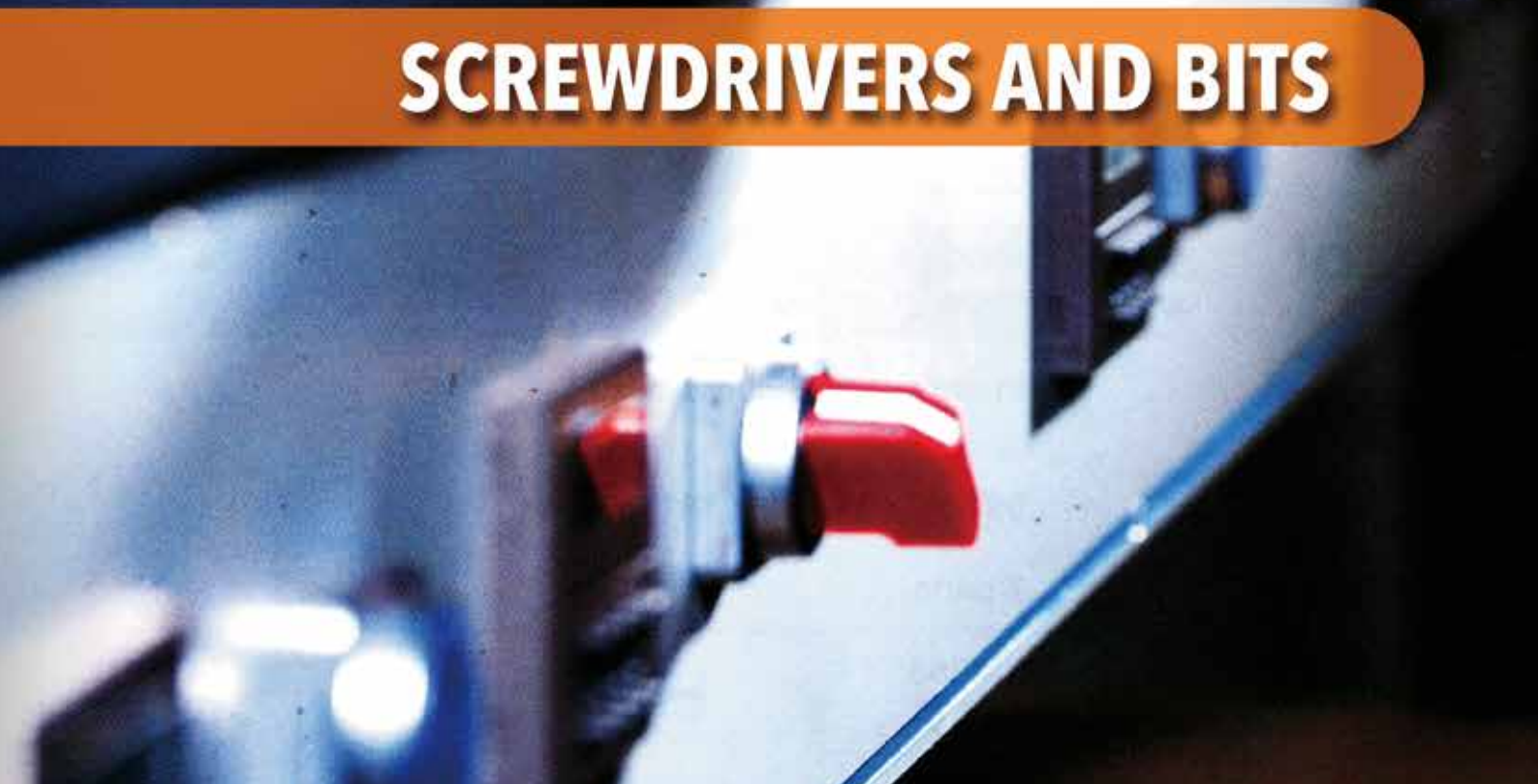

Screwdrivers Safety Uses



- Always wear safety glasses to protect the eyes.
- Always use insulated screwdriver with electrical lines.
- Use the correct end screwdriver for each screw.
- Beware of the established torque for each type of screwdriver.
- Do not use the screwdriver as a chisel or lever or punches.
- Do not modify or heat blades as this will impair performance.
- For extra torque, select a screwdriver with a hexagon shoulder to take a wrench, but never use pliers.
- Wood handled through-blade screw driver can withstand gentle tapping on the end to free seized fasteners.
- Avoid using screwdrivers as chisels, levers or punches.
- To avoid damage to fastener head or tool blade, always select the appropriate pattern, especially Phillips and Pozidriv, in the correct size.
- Plastic-handled screwdrivers are not insulated. Use 1000V tools when working on live components.
- Keep your free hand clear when driving home a fastener in case the screwdriver slips.
- Wear gloves.

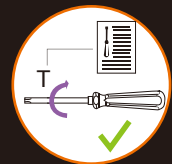
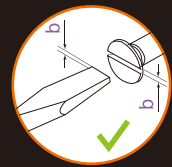
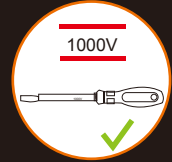

Select the correct pattern:

- Back blades for pozidriv
- Chrome blades for Phillips head





MK-TOL-200 COLOUR LINE SCREWDRIVER*

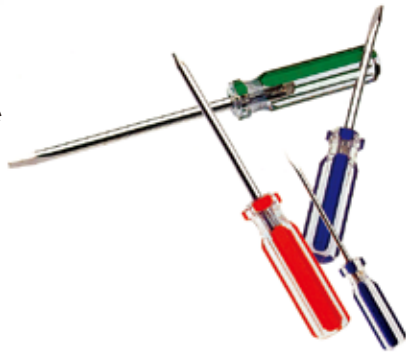

- Chrome molybdenum steel with proper heat treatment for extra durability and strength
- Chrome plated finish for extra rust resistance
- PVC handle and practical for light work
- Blade hardness: HRC 54°-58°
- Features colour handle for rapid identification: Red for Phillip, Green for slotted

Item Code	Blade Length		Ø	Box	Qty/Ctn	Price
	(mm)	(inch)				
MK-TOL-200-M5-075	75	3"	5	12	240	8.80
MK-TOL-200-M5-075/+	75	3"	5	12	240	8.80
MK-TOL-200-M5-100	100	4"	5	12	240	9.30
MK-TOL-200-M5-100/+	100	4"	5	12	240	9.30
MK-TOL-200-M5-150	150	6"	5	12	240	9.90
MK-TOL-200-M5-150/+	150	6"	5	12	240	9.90
MK-TOL-200-M5-200	200	8"	5	12	240	10.30
MK-TOL-200-M5-200/+	200	8"	5	12	240	10.30
MK-TOL-200-M6-038	38	1-1/2"	6	12	240	8.60
MK-TOL-200-M6-038/+	38	1-1/2"	6	12	240	8.60
MK-TOL-200-M6-100	100	4"	6	12	240	10.40
MK-TOL-200-M6-100/+	100	4"	6	12	240	10.40
MK-TOL-200-M6-125	125	5"	6	12	240	11.30
MK-TOL-200-M6-125/+	125	5"	6	12	240	11.30
MK-TOL-200-M6-150	150	6"	6	12	240	11.80
MK-TOL-200-M6-150/+	150	6"	6	12	240	11.80
MK-TOL-200-M6-200	200	8"	6	12	120	12.90
MK-TOL-200-M6-200/+	200	8"	6	12	120	12.90

MK-TOL-601 TORX MK-TOL-602 TORX



- TORX
- Chrome vanadium steel with proper heat treatment for extra durability and strength
 - Satin chrome plated finish for extra rust resistance with magnetic tip
 - Ergonomic rubber grip handle provides comfortable uses especially oily finger

Item Code	Blade Length	Box	Qty/Ctn	Price
MK-TOL-601-T05	T5	23	12	11.60
MK-TOL-601-T06	T6	23	12	11.60
MK-TOL-601-T07	T7	23	12	11.60
MK-TOL-602-T08	T8	23	12	14.10
MK-TOL-602-T09	T9	23	12	14.10
MK-TOL-602-T10	T10	41	12	16.80
MK-TOL-602-T15	T15	41	12	16.80
MK-TOL-602-T20	T20	41	12	16.80
MK-TOL-602-T25	T25	44	12	16.80
MK-TOL-602-T27	T27	50	12	17.60
MK-TOL-602-T30	T30	83	12	17.60
MK-TOL-602-T40	T40	136	12	21.80

MK-TOL-600 HEAVY DUTY SCREWDRIVER

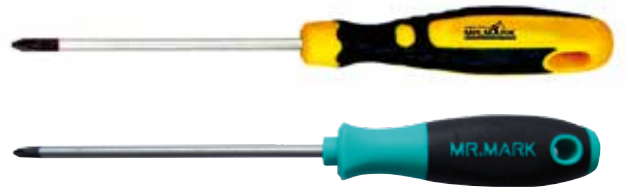

Satin chrome plated finish for extra rust resistance with magnetic tip

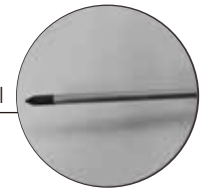

Chrome molybdenum steel



Ergonomic TPR grip handle provides comfortable uses especially oily finger

- Chrome molybdenum steel with proper heat treatment for extra durability and strength
- Satin chrome plated finish for extra rust resistance with magnetic tip
- Ergonomic TPR grip handle provides comfortable uses especially oily finger
- Blade hardness: HRC 54-58
- Features colour handle for rapid identification: Green for Philip, Yellow for slotted

Item Code	Blade Length		Ø	Box	Qty/Ctn	Price	
	(mm)	(inch)					
MK-TOL-600-M3-075	75	3"	3.0	36	12	240	13.70
MK-TOL-600-M3-075/+	75	3"	3.0	36	12	240	13.70
MK-TOL-600-M3-100	100	4"	3.0	41	12	240	13.90
MK-TOL-600-M3-100/+	100	4"	3.0	41	12	240	13.90
MK-TOL-600-M3-150	150	6"	3.0	43	12	240	15.00
MK-TOL-600-M3-150/+	150	6"	3.0	43	12	240	15.00
MK-TOL-600-M5-075	75	3"	5.0	42	12	144	13.40
MK-TOL-600-M5-075/+	75	3"	5.0	42	12	144	13.40
MK-TOL-600-M5-100	100	4"	5.0	79	12	144	14.30
MK-TOL-600-M5-100/+	100	4"	5.0	79	12	144	14.30
MK-TOL-600-M5-150	150	6"	5.0	140	12	144	13.80
MK-TOL-600-M5-150/+	150	6"	5.0	140	12	144	13.80
MK-TOL-600-M6-038	38	1 1/2"	6.0	38	12	144	13.10
MK-TOL-600-M6-038/+	38	1 1/2"	6.0	40	12	144	13.10
MK-TOL-600-M6-100	100	4"	6.0	82	12	144	16.10
MK-TOL-600-M6-100/+	100	4"	6.0	82	12	144	16.10
MK-TOL-600-M6-150	150	4"	6.0	146	12	144	17.00
MK-TOL-600-M6-150/+	150	4"	6.0	146	12	144	17.00
MK-TOL-600-M6-200	200	8"	6.0	160	12	120	19.10
MK-TOL-600-M6-200/+	200	8"	6.0	160	12	120	19.10
MK-TOL-600-M6-250	250	10"	6.0	170	12	120	22.40
MK-TOL-600-M6-250/+	250	10"	6.0	170	12	120	22.40
MK-TOL-600-M8-150	150	6"	8.0	168	12	120	22.20
MK-TOL-600-M8-150/+	150	6"	8.0	168	12	120	22.20
MK-TOL-600-M8-200	200	8"	8.0	175	12	96	26.00
MK-TOL-600-M8-200/+	200	8"	8.0	175	12	96	26.00



MK-TOL-604 HEAVY DUTY GO-THRU SCREWDRIVER



Satin chrome plated finish for extra rust resistance with magnetic tip

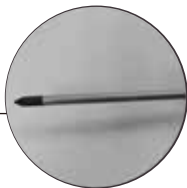

Chrome molybdenum steel



Ergonomic TPR grip handle provides comfortable uses especially oily finger

- High impact resistant chrome molybdenum steel with proper heat treatment for extra durability and strength
- Satin chrome plated finish for extra rust resistance with magnetic tip
- Ergonomic rubber grip handle provides comfortable uses especially oily finger
- Blade hardness: HRC 54-58
- Features colour handle for rapid identification: Green for Philip, Yellow for slotted

Item Code	Blade	Length	Ø	mm	Qty/Ctn	Price
	(mm)	(inch)				
MK-TOL-604-M6-100	100	4"	6	12	144	21.40
MK-TOL-604-M6-100/+	100	4"	6	12	144	21.40
MK-TOL-604-M6-150	150	6"	6	12	144	22.00
MK-TOL-604-M6-150/+	150	6"	6	12	144	22.00

MK-TOL-606 1000V VDE INSULATED SCREWDRIVER



- Chrome molybdenum steel with proper heat treatment for extra durability and strength
- Satin chrome plated finish for extra rust resistance with magnetic tip
- Ergonomic rubber grip handle provides comfortable uses especially oily finger
- Volt-Tested" to ensure safety on or near electrical equipment up to 1000 volts AC or 1500 volts DC
- Fully insulated to VDE/TUV/GS standard to protect from electric shocks up to 1000 volts

Item Code	Blade	Length	Ø	mm	Qty/Ctn	Price
	(mm)	(inch)				
MK-TOL-606-M6-150	150	6"	6.5	113 x 35	125	15.10
MK-TOL-606-M8-150/+	150	6"	8	121 x 38	180	18.50

MK-TOL-605 MKS ROUND BLADES SCREWDRIVER*



- Blade high alloy chrome vanadium steel.
- Satin chrome-plated.
- Black tip magnetic tip.
- USA PAT NO. 373945
- Ergonomic grip.
- DIN & ANS1 B107.1 Standard.
- Ergonomic grip triangular handle design improves user comfort. Chrome Vanadium steel blades with magnetic tips. Manufactured with convenient hanging hole in the handle for storage.

Item Code	Blade	Length	Ø	mm	Qty/Ctn	Price
	(mm)	(inch)				
MK-TOL-605-M5-100	100	4"	5	113 x 35	88	10.50
MK-TOL-605-M6-100	100	4"	6	113 x 35	88	10.90
MK-TOL-605-M6-100/+	100	4"	6	113 x 35	88	10.90
MK-TOL-605-M6-150	150	6"	6	113 x 35	98	12.90
MK-TOL-605-M6-150/+	150	6"	6	113 x 35	98	12.90
MK-TOL-605-M6-200	200	8"	6	113 x 35	180	15.90
MK-TOL-605-M6-200/+	200	8"	6	113 x 35	180	15.90

MK-TOL-608 DOUBLE WAY S/DRIVER



- Chrome molybdenum steel with proper heat treatment for extra durability and strength
- Anti-slip runner handle provides comfortable uses
- Two way (slotted/ Philip) drivers

ITEM CODE	DESCRIPTION	QTY/CTN	PRICE
MK-TOL-608	Double Way S/Driver	72	30.10

MK-TOL-609 PVC HANDLE SCREWDRIVER*



- Chrome vanadium steel with proper heat treatment for extra durability and strength
- Satin chrome plated finish for extra rust resistance with magnetic tip
- PVC handle provides comfortable uses
- Features colour handle for rapid identification: Red for Phillip, Green for slotted

ITEM CODE	DESCRIPTION	QTY/CTN	PRICE
MK-TOL-609-M4-300	300mm X M4 PVC Handle Screwdriver	30	14.90
MK-TOL-609-M4-300/+	300mm X M4 PVC Handle Screwdriver	30	14.90

MK-LITE-6023K 23PCS MR.MARK LITE SERIES SCREWDRIVER & BIT SET



"Ratchet type screwdriver handle increase operation efficiency"

Suitable for:



CONTENTS		QTY
Screwdriver	SL5 x 100mm, SL5 x 75mm PH1 x 100mm, PH1 x 75mm	4
Precision Screwdriver	PH0, SL2.0	2
Screwdriver Ratchet Handle	1/4"	1
25mm Bits (Philip, Slotted, Torx, Hex Socket)		16
Carrying Case		1

- For tightening and loosening different size and types of screws (Philip, slotted, Hex socket, Torx) for electrical, computer, kitchen appliances, DIY furniture assembly and many more
- Can be applied to mirror screw, sheet metal screw, wood screw, drywall screw, cap screw and etc
- Ratchet screwdriver handle provides comfortable uses and reduce work effort
- Ideal for home hobby, mechanics, contractors, carpenter, household and other

ITEM CODE	DESCRIPTION	QTY/CTN	PRICE
MK-LITE-6023K	23 Pcs Lite Series Screwdriver & Bit Set	10	72.80

MK-TOL-4606 IMPACT DRIVER KIT

- 1SET= 1KGS
- GW=22KGS/20SETS
- CUFT=0.7'

4870	IMPACT DRIVER
4800	8mm (5/16") BIT HOLDER
B831	⊖ 9, 11mm
B832	⊕ NO. 2, 3
METAL CASE: 195x65x47mm	



- Chrome vanadium steel with proper heat treatment for extra durability and strength
- Chrome plated finish for extra rust resistance
- Recommended bits is: MK-PH-280, MK-PH-380
- Ideal for motorcycle repair and automotive repair shop

ITEM CODE	DESCRIPTION	QTY/CTN	PRICE
MK-TOL-4606	Impact Driver Kit	18	88.60

MK-TOL-800 SCREWDRIVER*

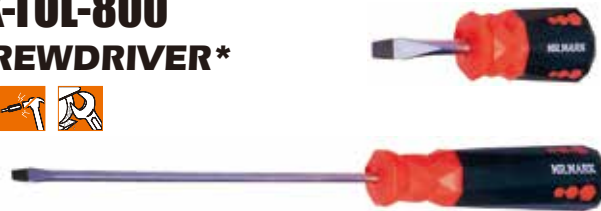

- Chrome molybdenum steel with proper heat treatment for extra durability and strength
- Satin chrome plated finish for extra rust resistance with magnetic tip
- Ergonomic rubber grip handle provides comfortable uses especially oily finger
- Features colour handle for rapid identification: Green for Phillip, Red for slotted

Item Code	Blade Length (mm)	Blade Length (inch)	Ø	⊖	⊕	Qty/Ctn	Price
MK-TOL-800-M3-125	125	5"	3	12	⊖	120	11.60
MK-TOL-800-M3-125/+/-	125	5"	3	12	⊕	120	11.60
MK-TOL-800-M3-150	150	6"	3	12	⊖	120	12.60
MK-TOL-800-M3-150/+/-	150	6"	3	12	⊕	120	12.60
MK-TOL-800-M6-038	38	1/2"	6	12	⊖	120	11.40
MK-TOL-800-M6-038/+/-	38	1/2"	6	12	⊕	120	11.40
MK-TOL-800-M6-100	100	4"	6	12	⊖	120	14.80
MK-TOL-800-M6-100/+/-	100	4"	6	12	⊕	120	14.80
MK-TOL-800-M6-125	125	5"	6	12	⊖	120	15.90
MK-TOL-800-M6-125/+/-	125	5"	6	12	⊕	120	15.90
MK-TOL-800-M6-150	150	6"	6	12	⊖	120	16.90
MK-TOL-800-M6-150/+/-	150	6"	6	12	⊕	120	16.90
MK-TOL-800-M6-200	200	8"	6	12	⊖	120	18.60
MK-TOL-800-M6-200/+/-	200	8"	6	12	⊕	120	18.60
MK-TOL-800-M6-250	250	10"	8	12	⊖	120	25.60
MK-TOL-800-M6-250/+/-	250	10"	8	12	⊕	120	25.60

MR. MARK POWER BIT

- Material: S2
- Magnetic tip
- Hardness HRC 58" - 62"



ITEM CODE	ITEM NO	SIZE(MM)	QTY/CTN	PRICE
MK-TOL-PH2045	MK-PH 2045⊕⊖	2X45	1200	4.40
MK-TOL-PH2045/+/-	MK-PH 2045⊕⊖	2X45	1200	4.40
MK-TOL-PH2065	MK-PH 2065⊕⊖	2X65	800	4.70
MK-TOL-PH2065/+/-	MK-PH 2065⊕⊖	2X65	800	4.70
MK-TOL-PH2110	MK-PH 2110⊕⊖	2X110	600	6.00
MK-TOL-PH2110/+/-	MK-PH 2110⊕⊖	2X110	600	6.00
MK-TOL-PH2150/+/-	MK-PH 2150⊕⊖	2x150	400	6.60

MR. MARK IMPACT POWER BIT

- Material: S2
- Magnetic tip
- Hardness HRC 58" - 62"



ITEM CODE	ITEM NO	SIZE	QTY/CTN	PRICE
MK-TOL-PH280	MK-PH 280	2x80	500	6.70
MK-TOL-PH380	MK-PH 380	3x80	500	6.70

MK-TOL-7024 250V VOLTAGE TEST PEN

- Test range of 100-500V
- Pocket size model with clip



ITEM CODE	DESCRIPTION	QTY/CTN	PRICE
MK-TOL-7024	250V Voltage Test Pen	200	8.00

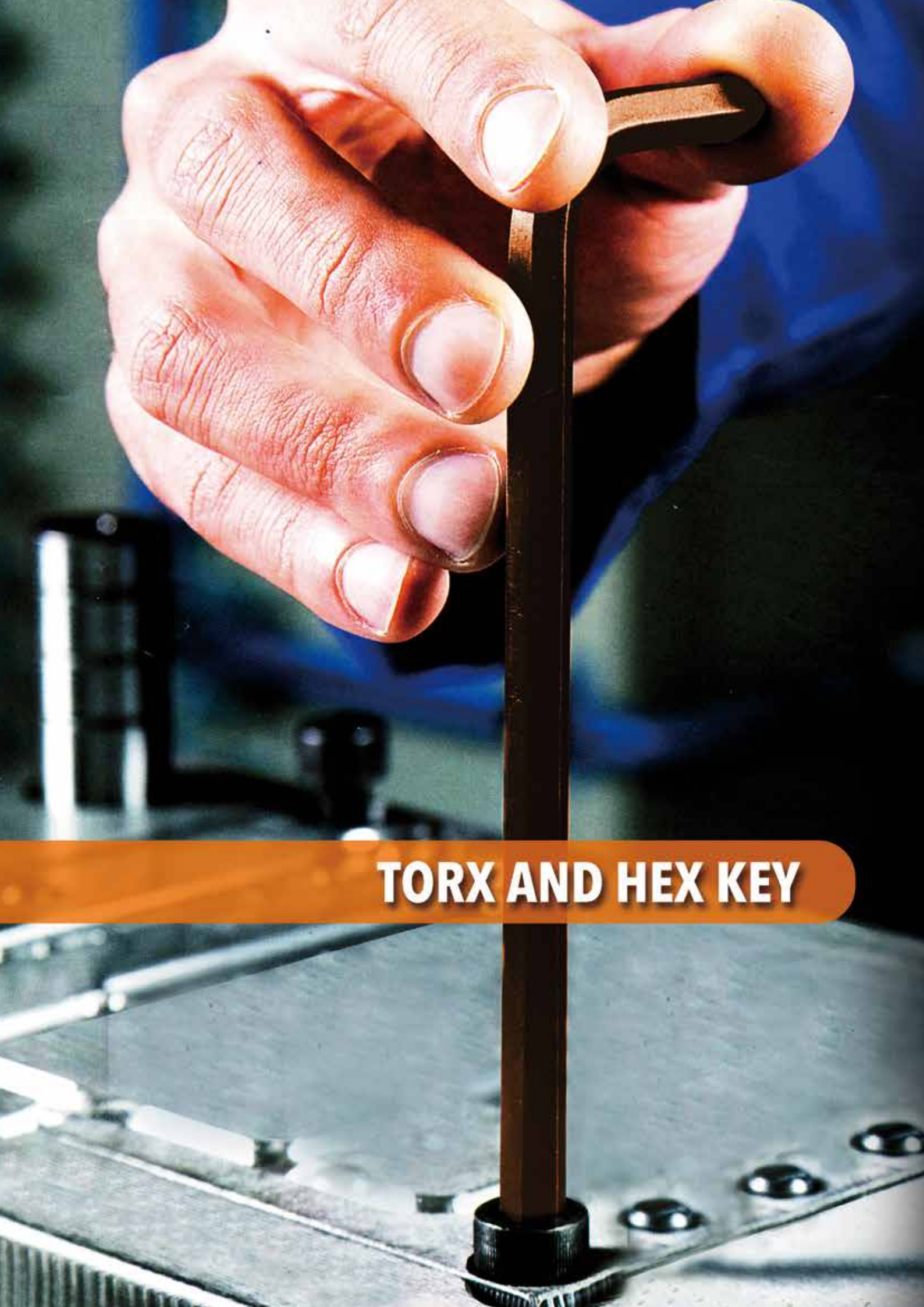

TORX AND HEX KEY

Hex Key Safety Uses

- Always wear safety glasses to protect the eyes.
- Wear gloves to protect the hands
- Use the correct size of wrench for each bolt or nut.
- Do not change the length of the lever using pipes or extension bar.
- Do not strike the wrench to tighten the screw.

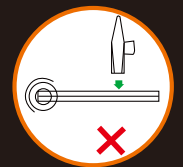
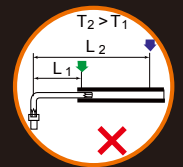

MK-TOL-3373 EXTRA LONG BALL POINT HEX KEY WRENCH

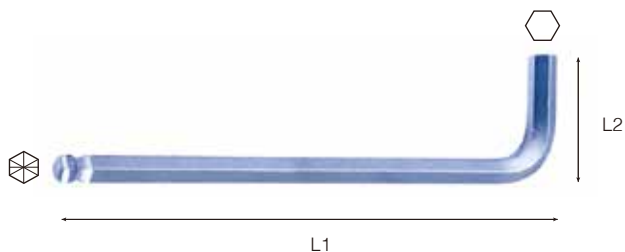

- Chrome vanadium steel with proper heat treatment for extra durability and strength
- Nickel plated finish for extra rust resistance
- Extra Long type with ball head

Item Code	Size (mm)	AARM (L1)	3373		g	QTY/CTN	Price
			EXTRA LONG ARM (L2)				
MK-TOL-3373-01.5	1.5	91.5	15.5	1.58	500	5.10	
MK-TOL-3373-02.0	2	102	77	3.13	500	5.70	
MK-TOL-3373-02.5	2.5	114.5	20.5	5.44	500	6.50	
MK-TOL-3373-03.0	3	129	23	8.84	500	6.50	
MK-TOL-3373-04.0	4	144	29	17.84	500	8.00	
MK-TOL-3373-05.0	5	165	33	31.88	500	9.70	
MK-TOL-3373-05.5	5.5	175.5	35.5	41.80	500	10.30	
MK-TOL-3373-06.0	6	186	38	51.90	300	10.90	
MK-TOL-3373-07.0	7	197	41	75.80	200	16.40	
MK-TOL-3373-08.0	8	208	44	102.30	200	16.40	
MK-TOL-3373-10.0	10	234	50	179.52	100	23.40	
MK-TOL-3373-12.0	12	262	57	289.80	75	31.40	
MK-TOL-3373-14.0	14	294	70	449.20	50	44.30	

MK-TOL-3514 T-HANDLE HEX WRENCH*

- Chrome vanadium steel with proper heat treatment for extra durability and strength
- Nickel plated finish for extra rust resistance
- Provides stronger torque than L type Allen key



Item Code	SIZE	L (mm)	Qty/Ctn	Price
MK-TOL-3514-H4	H4	H4 X 200 X 300MML	120	14.90
MK-TOL-3514-H5	H5	H5 X 200 X 300MML	120	14.90
MK-TOL-3514-H6	H6	H6 X 200 X 300MML	120	14.90

MK-TOL-3375 EXTRA LONG HEX KEY WRENCH

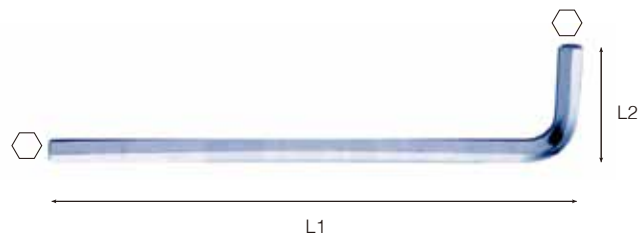

- Chrome vanadium steel with proper heat treatment for extra durability and strength
- Nickel plated finish for extra rust resistance
- Extra Long type with hexagon head (Allen)

Item Code	Size (mm)	AARM (L1)	3375		g	QTY/CTN	Price
			EXTRA LONG ARM (L2)				
MK-TOL-3375-01.5	1.5	91.5	15.5	1.58	500	2.40	
MK-TOL-3375-02.0	2	102	77	3.13	500	2.40	
MK-TOL-3375-02.5	2.5	114.5	20.5	5.44	300	3.00	
MK-TOL-3375-03.0	3	129	23	8.84	500	3.20	
MK-TOL-3375-04.0	4	144	29	17.84	500	5.10	
MK-TOL-3375-05.0	5	165	33	31.88	500	6.40	
MK-TOL-3375-05.5	5.5	175.5	35.5	41.80	500	6.40	
MK-TOL-3375-06.0	6	186	38	51.90	300	8.10	
MK-TOL-3375-07.0	7	197	41	75.80	300	9.80	
MK-TOL-3375-08.0	8	208	44	102.30	500	12.50	
MK-TOL-3375-09.0	9	219	47	140.20	200	15.00	
MK-TOL-3375-10.0	10	234	50	179.52	100	15.00	
MK-TOL-3375-12.0	12	262	57	289.80	300	35.00	
MK-TOL-3375-14.0	14	294	70	449.20	500	49.50	
MK-TOL-3375-17.0	17	337	80	756.60	25	75.60	
MK-TOL-3375-19.0	19	379	89	1048.20	20	104.70	

MK-TOL-3743 STAR KEY WRENCH*

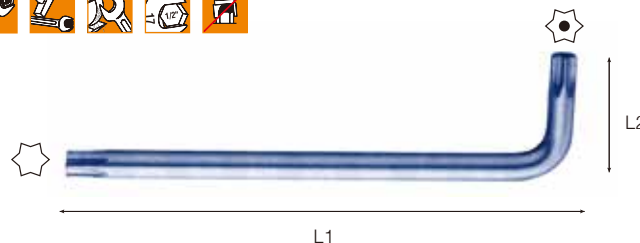

- Chrome vanadium steel with proper heat treatment for extra durability and strength
- Nickel plated finish for extra rust resistance
- Extra Long type with torx

Item Code	Size (mm)	AARM (L1)	3743		g	QTY/CTN	Price
			EXTRA LONG ARM (L2)				
MK-TOL-3743-T08	T08	76	16	5.16	500	7.20	
MK-TOL-3743-T09	T09	82	12	5.28	500	7.20	
MK-TOL-3743-T10	T10	90	14	5.83	500	7.20	
MK-TOL-3743-T15	T15	100	16	8.92	500	7.50	
MK-TOL-3743-T20	T20	110	18	12.83	500	8.40	
MK-TOL-3743-T25	T25	126	20	18.49	500	8.80	
MK-TOL-3743-T27	T27	140	24	25.61	500	8.90	
MK-TOL-3743-T30	T30	160	28	42.42	500	10.60	
MK-TOL-3743-T40	T40	176	32	63.79	500	12.20	
MK-TOL-3743-T45	T45	195	36	92.80	300	13.80	
MK-TOL-3743-T50	T50	217	40	130.44	200	14.60	
MK-TOL-3743-T50B	T50	217	40	130.44	150	14.60	

MK-TOL-3501M

7 PCS FOLDING TYPE HEX KEY TOOL



- S2 and chamfer steel with proper heat treatment for extra durability and strength
- Mirror copper finish for extra rust resistance
- Allen head wrench set

Item Code	Contains	Qty/Ctn	Price
MK-TOL-3501M	2.5, 3, 4, 5, 6, 8, 10mm	40	37.80

MK-TOL-3502M

7 PCS FOLDING TYPE STAR KEY TOOL



- S2 and chamfer steel with proper heat treatment for extra durability and strength
- Mirror copper finish for extra rust resistance
- Torx head wrench set

Item Code	Contains	Qty/Ctn	Price
MK-TOL-3502M	T10, T15, T20, T25, T27, T30, T40	60	41.90

MK-TOL-3503AF

9 PCS HEX KEY WRENCH SET



- Chrome vanadium steel with proper heat treatment for extra durability and strength
- Black finish for extra rust resistance
- Torx head wrench set

Item Code	Contains	Qty/Ctn	Price
MK-TOL-3503AF	1/16, 5/64, 3/32, 1/8, 5/32, 3/16, 1/4, 5/16, 3/8	72	23.30

MK-TOL-3504M

9 PCS HEX KEY WRENCH SET



- Chrome vanadium steel with proper heat treatment for extra durability and strength
- Black finish for extra rust resistance
- Torx head wrench set

Item Code	Contains	Qty/Ctn	Price
MK-TOL-3504M	1.5, 2, 2.5, 3, 4, 5, 6, 8, 10mm	72	25.50

MK-TOL-3505M

9 PCS EXTRA LONG BALL POINT HEX KEY WRENCH SET



- S2 and chamfer steel with proper heat treatment for extra durability and strength
- Mirror copper finish for extra rust resistance
- Extra Long type with ball head
- Ball head design allow the key to be easily inserted into the screw head and permits the key to be turned at an angle, which is very useful in tight corners.

Item Code	Contains	Qty/Ctn	Price
MK-TOL-3505M	1.5, 2, 2.5, 3, 4, 5, 6, 8, 10mm	36	81.70

MK-TOL-3506M

9 PCS EXTRA LONG BALL POINT HEX KEY WRENCH SET



- Chrome vanadium steel with proper heat treatment for extra durability and strength
- Nickel plated finish for extra rust resistance
- Extra Long type with ball head
- Ball head design allow the key to be easily inserted into the screw head and permits the key to be turned at an angle, which is very useful in tight corners.

Item Code	Contains	Qty/Ctn	Price
MK-TOL-3506M	1.5, 2, 2.5, 3, 4, 5, 6, 8, 10mm	48	67.00



MK-TOL-3507AF

7 PCS EXTRA LONG BALL POINT HEX KEY WRENCH SET

MK-TOL-3507M

7 PCS EXTRA LONG BALL POINT HEX KEY WRENCH SET



- S2 and chamfer steel with proper heat treatment for extra durability and strength
- Mirror copper finish for extra rust resistance
- Extra Long type with ball head
- Ball head design allow the key to be easily inserted into the screw head and permits the key to be turned at an angle, which is very useful in tight corners.

Item Code	Contains	Qty/Ctn	Price
MK-TOL-3507AF	3/32, 1/8, 5/32, 3/16, 1/4, 5/16, 3/8	36	61.50
MK-TOL-3507M	2.5, 3, 4, 5, 6, 8, 10mm	36	61.50

MK-TOL-3508AF

7 PCS EXTRA LONG HEX KEY WRENCH SET

MK-TOL-3508M

7 PCS EXTRA LONG HEX KEY WRENCH SET



- S2 and chamfer steel with proper heat treatment for extra durability and strength
- Mirror copper finish for extra rust resistance
- Extra Long type with hexagon head (Allen)

Item Code	Contains	Qty/Ctn	Price
MK-TOL-3508AF	3/32, 1/8, 5/32, 3/16, 1/4, 5/16, 3/8	36	55.20
MK-TOL-3508M	2.5, 3, 4, 5, 6, 8, 10mm	36	55.20

MK-TOL-3511M

9 PCS EXTRA LONG ARM HEX KEY WRENCH SET



- S2 and chamfer steel with proper heat treatment for extra durability and strength
- Mirror copper finish for extra rust resistance
- Extra Long type with hexagon head (Allen)
- Long arm wrenches provide extra reach and greater torque

Item Code	Contains	Qty/Ctn	Price
MK-TOL-3511M	1.5, 2, 2.5, 3, 4, 5, 6, 8, 10mm	36	59.00

MK-TOL-3512M

7 PCS EXTRA LONG ARM STAR KEY WRENCH SET



- S2 and chamfer steel with proper heat treatment for extra durability and strength
- Mirror copper finish for extra rust resistance
- Extra Long type with hexagon head (Allen)
- Long arm wrenches provide extra reach and greater torque

Item Code	Contains	Qty/Ctn	Price
MK-TOL-3512M	T10, T15, T20, T25, T27, T30, T40	72	65.30

MK-TOL-3513M

9 PCS EXTRA LONG ARM STAR KEY WRENCH SET



- S2 and chamfer steel with proper heat treatment for extra durability and strength
- Mirror copper finish for extra rust resistance
- Extra Long type with hexagon head (Allen)
- Long arm wrenches provide extra reach and greater torque

Item Code	Contains	Qty/Ctn	Price
MK-TOL-3513M	T10, T15, T20, T25, T27, T30, T40, T45, T50	36	93.20

CUTTING WHEEL, GRINDING WHEEL & ACCESORRIES



CUTTING & GRINDING WHEEL

- Before using abrasive wheels, carefully read safety guidelines, the regulations indicated on product label and instructions in boxes.
- Always wear heavy leather protective gloves that also cover forearms and wrists.
- Always wear suitable eye and face protections.
- Always wear ear protection measures such as ear plugs.
- Avoid prolonged exposure to vibrations as it can cause serious physiological damages to the operator.
- When mounting the wheel, check for cracks or damages.
- Never use wheels that have a higher diameter than the one shown on the grinder label or in the grinder's instructions manual.
- Use abrasive wheels only with the grinders for which they have been intended and use on suitable material only.
- Avoid clamping with too much pressure to prevent damage on abrasive wheel.
- Firmly fix the work pieces before starting any work
- Always use safety guard and verify that they are safe and in good condition.
- Do not use abrasive products in presence of combustible or flammable material.
- Keep working area clean and free of obstacles. Make sure the floor is not slippery.
- Stay outside the axis of rotation of the wheel when doing this.
- Stop using or replace a wheel if there is too much vibration in the operation.
- Ensure that damaged, defective and worn-out wheels are destroyed to prevent their usage.



MK-WEL-00680 "TITAN" TURBO DIAMOND CUTTER*

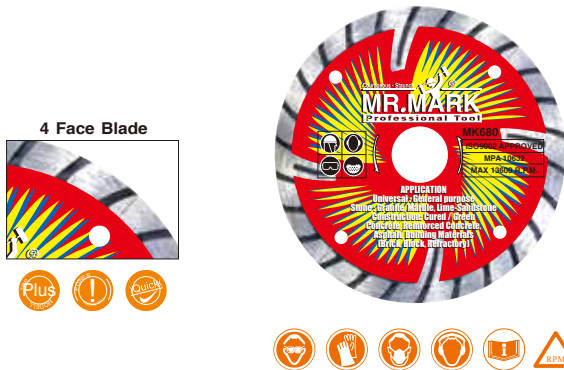

- Unique patented welding method uses diamond segment inserts. The diamond segment are incorporated into the steel centre and slots (gullet). Providing superior undercutting protection.
- Double turbo segments provide fast and superior cutting for value conscious users.

20mm Arbor

APPLICATION

- Universal : General purpose
- Stone : Granite, Marble, Lime-Sandstone
- Construction : Cured / Green Concrete Reinforced Concrete, Asphalt, Building Materials (Brick, Block, Refractory)

ITEM CODE	Size	R.P.M	QTY/CTN	PRICE
MK-WEL-00680-105	105 X 1.8 X 7 X20mm	13600	200	30.20

MK-WEL-00780 CONTINUOUS RIM DIAMOND WHEEL*

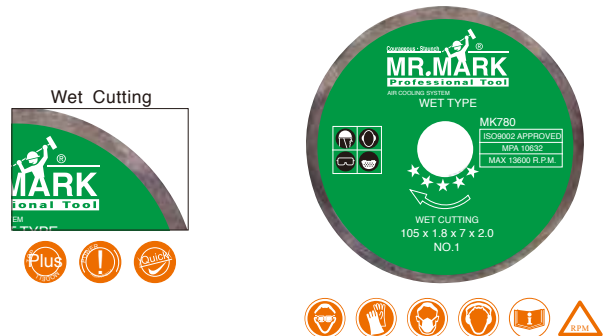

Smooth continuous rim tile blades are ideal when cutting ceramic tiles and marble. These wet cutting blades will deliver very fast chip free cutting on all delicate tiles and stones. Wet cutting reduces the chance of chipping the tile and promotes longer life to your blades. Steady cutting with better smoothness and no damage to the edge. Suitable for accurate wet-cutting of hard and brittle materials.

20mm Arbor

APPLICATION

- Tiles : Ceramic tile, enameled porcelain tile.
- Construction : Thin Granite, Marble slabs.

ITEM CODE	Size	R.P.M	QTY/CTN	PRICE
MK-WEL-00780-105	105 X 1.6 X 7 X20mm	13640	200	18.90

MK-WEL-00800 STANDARD DIAMOND WHEEL*

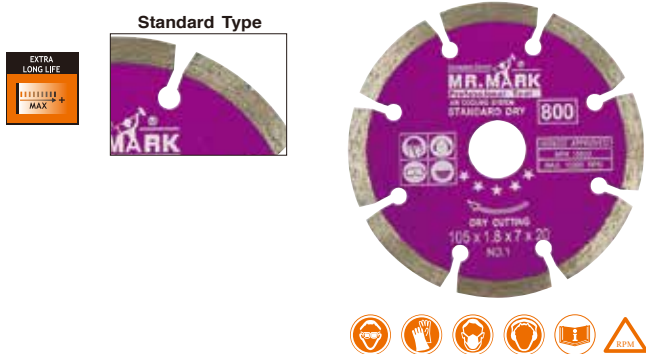

- Sintering is a widely used technology in the production of diamond discs. The Advantages include good performance, fast cutting, and an attractive price for the end-users. It's the best choice for stone fabricators, to get high efficiency and great value. Efficient, fast cutting at economical prices.

20mm Arbor

APPLICATION

- Universal : General purpose
- Stone : Granite, Marble, Lime-Sandstone
- Construction : Cured / Green Concrete, Reinforced Concrete, Asphalt, Building Materials (Brick, Block, Refractory)

ITEM CODE	Size	R.P.M	QTY/CTN	PRICE
MK-WEL-00800-NORM	105 X 1.8 X 7 X20mm	13640	200	20.80

MK-WEL-00880 SPEED CUT DIAMOND WHEEL*

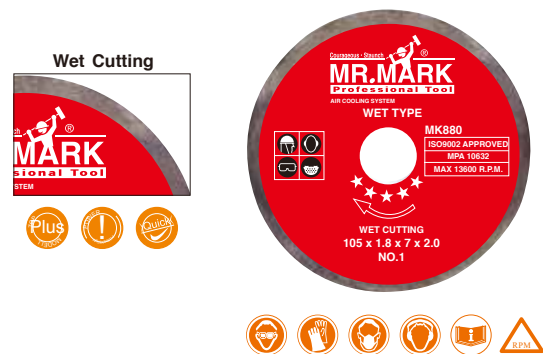

- Smooth continuous rim tile blades are ideal when cutting ceramic tiles and marble. These wet cutting blades will deliver very fast chip free cutting on all delicate tiles and stones. Wet cutting reduces the chance of chipping the tile and promotes longer life to your blades. Steady cutting with better smoothness and no damage to the edge. Suitable for accurate wet-cutting of hard and brittle materials.
- The design improve safety, cooling and clean cutting.
- Reduce blade flexing results in low noise.

20mm Arbor

APPLICATION

- Universal : General purpose
- Stone : Granite, Marble, Lime-Sandstone
- Construction : Cured / Green Concrete, Reinforced Concrete, Asphalt, Building Materials (Brick, Block, Refractory)

ITEM CODE	Size	R.P.M	QTY/CTN	PRICE
MK-WEL-00880-105	105 X 1.2 X 7 X20mm	13640	200	22.80



MK-WEL-00980 PRO LASER WELDED SAW BLADES*



- High-performance "PRO" -plus product line features high-grade diamond grain and a heat-treated (pre-stressed) steel blade.
- Provide fast and superior cutting for conscious users.

20mm Arbor

APPLICATION

- Universal : General purpose
- Stone : Granite, Marble, Lime-Sandstone
- Construction : Cured / Green Concrete, Reinforced Concrete, Asphalt, Building Materials (Brick, Block, Refractory)

ITEM CODE	Size	R.P.M	QTY/CTN	PRICE
MK-WEL-00980-105	105 X 1.8 X 7 X20mm	13600		30.20

MK-WEL-12001 HAND MACHINISTS' FILES*



BOX OF 12 PCS

- Shape : Edges and surfaces parallel, surfaces double cut. one edge single cut.
- Universal : For filling flat surfaces, sharp corners and shoulders as well as for deburring. A double cut file should be used for work in high-alloy tool steel. Also useful for the sharpening of heavy implements. Specially for general work on iron and steel.

ITEM CODE	2ND CUT	QTY/CTN	PRICE
MK-WEL-12001B-06	6"	20 doz	122.80/doz
MK-WEL-12001B-08	8"	12 doz	167.30/doz

MK-WEL-12003 THREE SQUARE MACHINISTS' FILES*



- Shape : Equilateral triangle. Tapered towards the point. Double cut surfaces.
- Universal : For deburring and filling angles and inner corners. For filling of holes and large fillets as well as concave surfaces. Its tapered surfaces make it well suited for flat filling.

ITEM CODE	L(mm)	L(inch)	W	T	QTY/CTN	PRICE
MK-WEL-12003-4	100	4	9	-	330	12 doz 144.40/doz

MK-WEL-01200 PREMIUM DIAMOND WHEEL*



- The segment is bonded tightly to the steel base by brazing under high-frequency electrical current. Professional range designed for wall chasing : providing maximum performance and fast cutting supergrade quality.

20mm Arbor

APPLICATION

- Universal : General purpose
- Stone : Very Hard Granite, Sandstone
- Construction : Building Materials (Brick, Block, Refractory)

ITEM CODE	Size	R.P.M	QTY/CTN	PRICE
MK-WEL-01200	105 X 1.7 X 7 X20mm	13460		30.20

MK-WEL-12002 HALF ROUND MACHINISTS' FILES*



BOX OF 12 PCS

- Shape : Edges and surfaces, tapered towards the point, 6" fully pointed, 8" semi-pointed, Double cut.
- Universal : For filling concave and flat surfaces and large holes, suitable for deburring work.

ITEM CODE	2ND CUT	QTY/CTN	PRICE
MK-WEL-12002B-08	8"	16 doz	233.80/doz

MK-WEL-12004 TAPER SLIM SAW FILES*



- Shape : Triangular, with edges tapering towards the point, surfaces and edges single cut, width figures indicate the largest width of the file section.
- Universal : For sharpening all types of saw with fire cross toothing.

ITEM CODE	L(mm)	L(inch)	CONTENTS	QTY/CTN	PRICE
MK-WEL-12004-4	125	4	Slim Tapered	12 doz	56.40/doz



MK-WEL-12005 CHAIN SAW SAW FILES*



Shape : Round chain saw file for sharpening of the cutting tooth or the sawchian.
Excellent filling performance, reducing the necessary sharpening time.
Universal : Specially for sharpening for sharpening chain saw.

ITEM CODE	L(mm)	L(inch)	T	QTY/CTN	PRICE
MK-WEL-12005-13/64	200	8	13/64	12	58.80
MK-WEL-12005-3/16	200	8	3/16	12	58.80
MK-WEL-12005-7/32	200	8	7/32	12	58.80

MK-WEL-12200 FLAP DISC



- Aluminium oxide is characterized by a very good abrasive action and a hardness grade.
- The value-for-money enhanced alternative for uncomplicated general purpose DIY and trade use.
- Universally suitable for use on different materials e.g., steels, metal, high-grade steels, plastics and wood.
- Universal use, High stock removal rate, long service life, reduced operator fatigue.

ITEM CODE	Grit No.	Size	QTY/CTN	PRICE
MK-WEL-12200-040	Grit40	100mm X 16mm	200	4.10
MK-WEL-12200-060	Grit60	100mm X 16mm	200	4.10
MK-WEL-12200-080	Grit80	100mm X 16mm	200	4.10
MK-WEL-12200-100	Grit100	100mm X 16mm	200	4.10
MK-WEL-12200-120	Grit120	100mm X 16mm	200	4.10

MK-WEL-12320 (100mm / 4") 'MASTER' FIBRE DISC



The master fibre disc is made of synthetic resin and abrasives Aluminium coated on the vulcanized fibre backing. It is ideal for deburring and polishing welding seam, removing rust, old paint. It is mainly used for automobile, ship, machinery, instrument and etc.

ITEM CODE	Grit No.	QTY/CTN	PRICE
MK-WEL-12320-P024	P24	1000	2.00
MK-WEL-12320-P036	P36	1000	2.00
MK-WEL-12320-P060	P60	1000	2.00
MK-WEL-12320-P080	P80	1000	2.00
MK-WEL-12320-P120	P120	1000	2.00

MK-WEL-12100 SUPER LINE FLAP DISC*



- Zirconia grain with a high strength for maximum grinding efficiency in stainless steel, no-ferrous steel, steel and alloys.
- The value-for-money enhanced alternative for professional applications in industry.
- Universal use, high stock removal rate, good edgholding properties, extra long service life even in heavy-duty, aggressive abrasive action.

ITEM CODE	Grit No.	Size	QTY/CTN	PRICE
MK-WEL-12100-040	Grit40	100mm X 16mm	200	10.80
MK-WEL-12100-060	Grit60	100mm X 16mm	200	10.80
MK-WEL-12100-080	Grit80	100mm X 16mm	200	10.80
MK-WEL-12100-120	Grit120	100mm X 16mm	200	10.80

MK-WEL-12300 (100mm / 4") 'MASTER' FIBRE DISC



The master fibre disc is made of synthetic resin and abrasives Silicon Carbon coated on the vulcanized fibre backing. It is ideal for removing rust, old paint. It is mainly used for ship, marble, aviation, bridge and building.

ITEM CODE	Grit No.	QTY/CTN	PRICE
MK-WEL-12300-P024	P24	1000	2.20
MK-WEL-12300-P036	P36	1000	2.20
MK-WEL-12300-P060	P60	1000	2.20
MK-WEL-12300-P080	P80	1000	2.20
MK-WEL-12300-P120	P120	1000	2.20

MK-WEL-12400 DEPRESSED GRINDER WHEEL (A 24 QBF)



APPLICATION Universal : General purpose for metal (Long life) Provides longer wheel life especially suitable for edge grinding of all metal and castings

ITEM CODE	Size	R.P.M	QTY/CTN	PRICE
MK-WEL-12400-04G	100 X 6 X 16mm (4")	13700 (72m/s)	200	2.60
MK-WEL-12400-07G	180 X 6 X 22.23mm (7")	7600 (72m/s)	50	8.10



MK-WEL-12420T
MULTI-PURPOSE CUTTER
(20 TEETH)*



20mm Arbor

APPLICATION ★★★★★

Universal : General purpose for Wood, Aluminium, Roof, PVC Pipe, Building Materials.

ITEM CODE	Size	R.P.M	QTY/CTN	PRICE
MK-WEL-12420T	4 - 1/8" (105mm)	13640	100	16.40

MK-WEL-12440T
MULTI-PURPOSE CUTTER (40 TEETH)



20mm Arbor

APPLICATION ★★★★★

Universal : General purpose for Wood Aluminium, Roof, PVC Pipe, Building Materials.

ITEM CODE	Size	R.P.M	QTY/CTN	PRICE
MK-WEL-12440T	4 - 1/8" (105mm)	13640	100	18.20

MK-WEL-12460
(100 x 2 x 60mm)
POLISHING PADS
(COARSE)*



APPLICATION ★★★★★

Using for mable and granite polishing of wet operations by water lubrication High quality diamond and heavy duty resin bond result in rapid, easy removable and extremely longer working life.

ITEM CODE	Grit	Finish	QTY/CTN	PRICE
MK-WEL-12460-060	60	Extra Coarse	200	5.90
MK-WEL-12460-080	80	Coarse	200	5.90
MK-WEL-12460-120	120	Medium	200	5.90

MK-WEL-12500 (100mm / 4")
NON WOVEN GRINDING DISC*



These peripheral grinding tools are designed for flexible deburring, cleaning and fine grinding of difficult workpiece contours. Up to three discs can be stacked to achieve an optimum tool width. The typical grinding action of these wheels ensures very smooth transitions. The ideal tool for automotive bodywork. Irregularities in the workpiece surface (even cracks and holes) are effectively removed.

ITEM CODE	Diameter	Arbor Hold	Max. RPM	QTY/CTN	PRICE
MK-WEL-12500-100	100mm / 4"	M10 X 1.5	12500	200	34.80

MK-WEL-12550
4" RIP STRIP DISC*



Clean and strip disc metallic surfaces without material removal. They are a safer alternative to wire brushes. The primary applications for clean and strip discs include:

- Removal of paint and adhesives.
- Cleaning of weld seams.
- Removal of welding scale and discoloration.
- Surface preparation for auto body work.

ITEM CODE	Diameter	Max. RPM	QTY/CTN	PRICE
MK-WEL-12550-04	100mm / 4"	10000	320	19.80

MK-WEL-12600AC
FLEXIBLE SOFT DISC GRINDING WHEEL
(AC 80)



105mm x 3 x 16mm (4")

APPLICATION ★★★★★

Universal : Recommended for carbon steel, Cerement carbide Absorb frictional impacts and Vibration for right angle grinders in both grinding and fine finishing operations performs on wide range of materials and give smooth running on your grinders

ITEM CODE	Size	R.P.M	QTY/CTN	PRICE
MK-WEL-12600-04AC	4" x 1/8" x 5.8mm	13700 (72m/s)	200	2.70



MK-WEL-12600-04WA
FLEXIBLE SOFT DISC GRINDING WHEEL
(WA 80)



105mm x 3 x 16mm (4")

APPLICATION

Universal : Recommended for Stainless Steel, Cerement carbide Absorb frictional impacts and Vibration for right angle grinders in both grinding and fine finishing operations performs on wide range of materials and give smooth running on your grinders

ITEM CODE	Size	R.P.M	QTY/CTN	PRICE
MK-WEL-12600-04WA	4" x 1/8" x 5.8mm	13700 (72m/s)	200	2.90

MK-WEL-12680
WET & DRY ABRASIVE PAPER



Applications:

Waterproof abrasive paper for wet and dry sanding, special flexible for sanding of irregular surface of auto industries, mechanical components and precision instrument and hardware.

ITEM CODE	DESCRIPTION	QTY/CTN	PRICE
MK-WEL-12680-080	9x11" GRIT NO.80#	1000	1.20
MK-WEL-12680-100	9x11" GRIT NO.100#	1000	1.20
MK-WEL-12680-120	9x11" GRIT NO.120#	1000	1.20
MK-WEL-12680-150	9x11" GRIT NO.150#	1000	1.20
MK-WEL-12680-180	9x11" GRIT NO.180#	1000	1.20
MK-WEL-12680-240	9x11" GRIT NO.240#	1000	1.20
MK-WEL-12680-280	9x11" GRIT NO.280#	1000	1.20
MK-WEL-12680-320	9x11" GRIT NO.320#	1000	1.20
MK-WEL-12680-400	9x11" GRIT NO.400#	1000	1.20
MK-WEL-12680-500	9x11" GRIT NO.500#	1000	1.20
MK-WEL-12680-600	9x11" GRIT NO.600#	1000	1.20
MK-WEL-12680-800	9x11" GRIT NO.800#	1000	1.20
MK-WEL-12680-1000	9x11" GRIT NO.1000#	1000	1.20
MK-WEL-12680-1200	9x11" GRIT NO.1200#	1000	1.20
MK-WEL-12680-1500	9x11" GRIT NO.1500#	1000	1.20

MK-WEL-12710
GRINDING WHEEL FOR METAL*

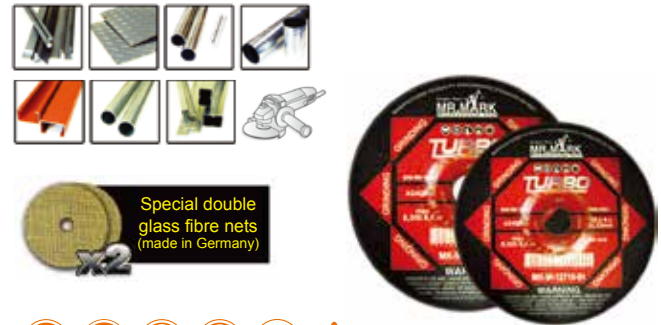

- Features
- Premium aluminium oxide grain
 - Two and half glass fibre nets
 - A24 R-BF medium hard bond
 - T27 depressed center
- Benefits
- General purpose, good service life
 - Good stock removal
 - Perfect ratio between cutting performance and life
- Application
- For all metal grinding application

ITEM CODE	Size	R.P.M	QTY/CTN	PRICE
MK-WEL-12710-04	100 x 6 x 16mm (4")	15200 (80m/s)	200	3.20
MK-WEL-12710-07	100 x 6 x 22mm (7")	8500 (80m/s)	50	8.80

MK-WEL-12730
THINNER CUTTING WHEEL
FOR METAL*



- Features
- Premium White & Brown aluminium oxide grain
 - Special double glass fibre nets
 - AZ46 S-BF highly advanced bond system
 - State of the art manufacturing
- Benefits
- Fastest initial cut of other wheel highest productivity
 - Cutting & grinding 2 in 1 performance
 - Free, cool cut, long time fresh
 - Accurate cutting while minimizing east and burrs
 - Superior safety when working
- Application
- For all metal cutting application

ITEM CODE	Size	R.P.M	QTY/CTN	PRICE
MK-WEL-12730-04	105 x 2.0 x 16mm (4")	15200 (80m/s)	300	2.20
MK-WEL-12730-07	180 x 3.0 x 22mm (7")	8500 (80m/s)	100	6.40
MK-WEL-12730-12	305 x 3.0 x 25.4mm (12")	5100 (80m/s)	25	13.50



MK-WEL-12800
REINFORCED RESIN BONDED CUT-OFF
WHEEL (A 36 QBF)



- High specific cutting rates.
- High load resistance.
- High resistance to fracture due to premium fibre reinforcements.
- Optimum tool life according to application requirement.
- Technological benefits of a fully symmetrical structure.
- Efficient, fast cutting at economical price.

APPLICATION

Universal : General purpose for metal

- Fast cut wheels for the broad range of steel and ferrous metal.

ITEM CODE	Size	R.P.M	QTY/CTN	PRICE
MK-WEL-12800-04	100 x 2.5 x 16mm (4")	13700 (72m/s)	300	1.50
MK-WEL-12800-07	180 x 3 x 22mm (7")	7600 (72m/s)	100	5.60
MK-WEL-12800-12	300 x 3 x 25.4mm (12")	4600 (72m/s)	25	11.50
MK-WEL-12800-14	350 x 3 x 25.4mm (14")	3900 (72m/s)	25	13.30
MK-WEL-12800-16	400 x 3 x 25.4mm (16")	3400 (72m/s)	25	17.00

MK-WEL-13000 CUP BRUSH
Electric Tools Used Flexible Type



- Using quality steel wire with a high tensile strength. Provide good balance and safety. Also economical tool life.

Warning : Failure to observe safety precautions may result in injury! This safety rules are important ones, observes them at all times in your own interest.

ITEM CODE	DIAMETER	LENGTH	THREAD/HOLE	R.P.M	QTY/CTN	PRICE
MK-WEL-13000-1.5	75m/m-3"	25	M10 x 1.5	12500	100	10.30
MK-WEL-13000-1.25*	75m/m-3"	25	M10 x 1.25	12500	100	10.30
MK-WEL-13000-2.0*	100m/m-4"	30	M14 x 2.0	9000	40	16.40

MK-WEL-13002
STEEL WIRE WHEEL BRUSH
Flexible Type



MEDIUM FACE

- Using quality steel wire with a high tensile strength; this gives long and economical tool life.
- Suitable for use with power drills. Crimped steel filaments add extra rigidity and cleaning power.

Warning : Failure to observe safety precautions may result in injury! This safety rules are important ones, observes them at all times in your own interest.

ITEM CODE	DIAMETER	L	W	ARBOR/HOLE	R.P.M	QTY/CTN	PRICE
MK-WEL-13002-100	100m/m-4"	15	35	25.4-1/2"	6000	60	14.00
MK-WEL-13002-125	125m/m-5"	18	55	25.4-1/2"	4500	40	16.30
MK-WEL-13002-150	150m/m-6"	20	55	25.4-1/2"	4500	40	23.60
MK-WEL-13002-200	200m/m-8"	20	55	25.4-1/2"	4500	20	34.00

MK-WEL-12900 (Super Slim Type)
GOLD STAR REINFORCED RESIN
BONDED CUT OFF WHEEL
(NA 60 RBF)



105mm x 1 x 16mm (4")

APPLICATION



Universal : Specially recommended for stainless steel. Thin high-power cutting disc, especially suitable for thin-walled materials, e.g. steel sheet, tubing and pipes, steel sections, wires. Very high cutting power and long working life. Low material consumption, low energy, low tool load.

ITEM CODE	Size	R.P.M	QTY/CTN	PRICE
MK-WEL-12900-04	4" x 4/64" x 5.8mm	14360 (80m/s)	200	2.30

MK-WEL-13001 CUP BRUSH
Air Tools Used Flexible Type



- Using quality steel wire with a high tensile strength. Provide good balance and safety. Also economical tool life.

Warning : Failure to observe safety precautions may result in injury! This safety rules are important ones, observes them at all times in your own interest.

ITEM CODE	DIAMETER	LENGTH	THREAD/HOLE	R.P.M	QTY/CTN	PRICE
MK-WEL-13001-075	75m/m-3"	25	16m/m-5/8"	12500	100	10.90
MK-WEL-13001-100	100m/m-4"	30	16m/m-5/8"	9000	40	17.70

MK-WEL-13003
CUP BRUSH WITH SHANK
For use on drills and high speed electric tools



- Using quality steel wire with a high tensile strength; this gives long and economical tool life.
- Suitable for use with power drills. Crimped steel filaments add extra rigidity and cleaning power.

Warning : Failure to observe safety precautions may result in injury! This safety rules are important ones, observes them at all times in your own interest.

ITEM CODE	DIAMETER	LENGTH	ARBOR/HOLE	R.P.M	QTY/CTN	PRICE
MK-WEL-13003-040	40m/m-1 1/2"	20	6	4500	200	7.80
MK-WEL-13003-050	50m/m-2"	20	6	4500	200	8.20
MK-WEL-13003-065	65m/m-2 1/2"	25	6	4500	120	9.20
MK-WEL-13003-075	75m/m-3"	25	6	4500	120	10.30



MK-WEL-13004
STEEL WIRE WHEEL BRUSH WITH SHANK



MEDIUM FACE

- Using quality steel wire with a high tensile strength; this gives long and economical tool life.
- Suitable for use with power drills. Crimped steel filaments add extra rigidity and cleaning power.

Warning : Failure to observe safety precautions may result in injury! This safety rules are important ones, observes them at all times in your own interest.

ITEM CODE	DIAMETER	LENGTH	SHANK	R.P.M	QTY/CTN	PRICE
MK-WEL-13004-030	30m/m-1 1/2"	6m/m	6m/m	4500	200	7.30
MK-WEL-13004-040	40m/m-1 1/4"	6m/m	6m/m	4500	200	7.80
MK-WEL-13004-050	50m/m-2"	6m/m	6m/m	4500	200	8.20
MK-WEL-13004-065	65m/m-2 1/2"	6m/m	6m/m	4500	150	8.90
MK-WEL-13004-075	75m/m-3"	6m/m	6m/m	4500	150	10.00
MK-WEL-13004-100	100m/m- 4"	6m/m	6m/m	4500	100	10.70

MK-WEL-13006
10" BRAKE SHOE CLEANING BRUSH
Plastic covered handle Metal sheet body Chrome plated



For cleaning brake drums and shoes.

ITEM CODE	DESCRIPTION	QTY/CTN	PRICE
MK-WEL-13006	10" Brake Shoe Cleaning Brush	100	7.50

MK-WEL-13005 END BRUSH
For use on drills and high speed electric tools



- Using quality steel wire with a high tensile strength; this gives long and economical tool life.
- For hand to reach areas such as Drilled holes, recesses and corners. For removal of burrs, rust and paint.
- Flat trimmed brushes with brassed and crimped filaments.

ITEM CODE	DIAMETER	L	OVERALL LENGTH	SHANK	R.P.M	QTY/CTN	PRICE
MK-WEL-13005-010	10m/m-3/8"	20m/m	70m/m	6m/m	20000	250	4.60
MK-WEL-13005-016	16m/m-5/8"	25m/m	75m/m	6m/m	20000	200	6.00
MK-WEL-13005-020	20m/m-3/4"	25m/m	75m/m	6m/m	20000	200	7.00
MK-WEL-13005-025	25m/m-1"	25m/m	75m/m	6m/m	20000	200	7.80



VEHICLES & BODY REPAIR TOOLS

Vices Safety Uses

- Fit the vice securely to a suitable sized support.
- Never use an extension or a hammer to tighten a vice. Avoid clamping hard towards the end of the jaws.
- Do not use the jaws as an anvil.
- Never modify or repair a vice.
- Always wear eye and hand protection when grinding, sawing, drilling, and hammering.
- Select a swivel-base vice so that you approach the workpiece from the best angle.
- Do not use a hammer or extension to increase pressure.

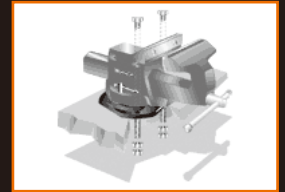

- Fix vice securely to bench



- Don't use a hammer or extension to increase pressure.



SUSPENSIONS



MK-AUT-10001 DROP FORGED COIL SPRING COMPRESSOR (BIG TYPE)

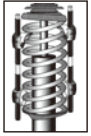

- Drop forged CR-V steel Jaws & lead screws (370mm) both heat treated ensured you obtain professional job performance.
- The tool is designed for use in limited space under wheel arch.
- Jaws design is fitting to wrap coil claws for safety.
- Maximum jaw opening is 370mm.

ITEM CODE	DESCRIPTION	QTY/CTN	PRICE
MK-AUT-10001	Drop Forged Coil Spring Compressor	10	250.50

ENGINE



MK-AUT-10002 VALVE SPRING COMPRESSOR

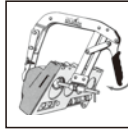

- Reversible jaw adaptor for multi-valve engines.
- Capacity 45mm-145mm, throated cleance 250mm.
- Big window jaw adaptor for easy replacement of valve collect.

ITEM CODE	DESCRIPTION	QTY/CTN	PRICE
MK-AUT-10002	Valve Spring Compressor	10	339.80

ENGINE



MK-AUT-10004 PISTON RING COMPRESSOR

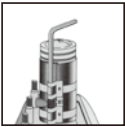

- Designed for rapid insertion of piston into the cylinder. The square adjustment key forces the clutch into the grooves and a clutch control prevent them from expanding.
- Different height and diameter for the various sizes and number of rings.

ITEM CODE	HEIGHT	CAPACITY (mm)	N.W kgs	G.W kgs	QTY/CTN	PRICE
MK-AUT-10004-3125	3"	53-125	15.5	17	50	55.90
MK-AUT-10004-3175	3"	53-175	17	18.5	50	63.80
MK-AUT-10004-4175	4"	60-175	19	20.5	50	70.50
MK-AUT-10004-6175	6"	60-175	22.5	24	20	126.90

STEERING & TRANSMISSION



MK-AUT-10005 BEARING SEPARATOR

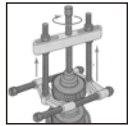

ITEM CODE	CAPACITY	HARDENED	BOLT	QTY/CTN	PRICE
MK-AUT-10005-050	1 1/4- 2 1/4"	42°-45°	ø9.5mmx L125mm x 3/8" x 24t)	60	119.70
MK-AUT-10005-075	2 1/4- 3 1/2"	42°-45°	ø12.7mmx L135mm x 1/2" x 20t)	48	156.30
MK-AUT-10005-100	3"- 4 1/2"	42°-45°	ø16mmx L165mm x 5/8" x 18t)	48	214.20
MK-AUT-10005-150	4"- 6"	42°-45°	ø19mmx L260mm x 3/4" x 16t)	48	463.90
MK-AUT-10005-200	6"- 8"	42°-45°	ø1"mmx L135mm x 1" x 12t)	48	981.80

STEERING & TRANSMISSION



MK-AUT-10006 2 JAW GEAR PULLER*

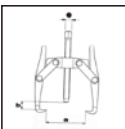

For removing gears, ball races, bearing, pulleys and sprockets from drive shafts.

- Chrome vanadium steel.
- 3s dynamic profile.



ITEM CODE	SIZE	WEIGHT	QTY/CTN	PRICE
MK-AUT-10006-3	3"	18/19kg	20	46.60
MK-AUT-10006-4	4"	24/25kg	20	73.10
MK-AUT-10006-6	6"	22.5/23.5kg	12	116.10
MK-AUT-10006-8	8"	24/25kg	5	206.60

STEERING & TRANSMISSION



MK-AUT-10007 3 JAW GEAR PULLER

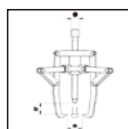

For removing gears, ball races, bearing, pulleys and sprockets from drive shafts.

- Chrome vanadium steel.
- 3s dynamic profile.



ITEM CODE	SIZE	WEIGHT	QTY/CTN	PRICE
MK-AUT-10007-3	3"	24/25kg	24	70.00
MK-AUT-10007-4	4"	22.5/23.5kg	24	97.70
MK-AUT-10007-6	6"	24/25kg	12	168.70
MK-AUT-10007-8	8"	19/20kg	4	295.00

STEERING & TRANSMISSION



MK-AUT-10008 BALL JOINT PULLER (LIGHT SERIES)*

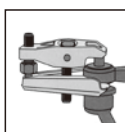

- For extracting ball joint from steering wheel and suspension.
- Forged steel body with chemically blackened thrust and adjustment screws for corrosion resistance.
- Fully adjustable

ITEM CODE	DESCRIPTION	QTY/CTN	PRICE
MK-AUT-10008	Ball Joint Puller Light Series	60	154.60

STEERING & TRANSMISSION



MK-AUT-10010 DISC BRAKE PISTON SPREADER

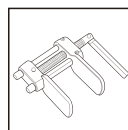

- From mini cars to small trucks.
- Fits in brake caliper to push back pistons for new brake pads installation.
- Patented.

ITEM CODE	DESCRIPTION	QTY/CTN	PRICE
MK-AUT-10010	Disc Brake Piston Spreader	15	210.70



STEERING & TRANSMISSION



MK-AUT-10011 BEARING PULLER



- The design of this puller is particular suited to cage-type ball bearing.
- Pressure is distributed over two races and the tool can be used for both shaft and housing fits.
- Depending on ball diameter, different pair of spherical tips should be selected from one of the three sets available.



ITEM CODE	DIASSEMBLY OUTWHEEL CAPACITY	QTY/CTN	PRICE
MK-AUT-10011-1935	19-35MM	48	123.40
MK-AUT-10011-2455	24-55MM	24	148.80
MK-AUT-10011-3580	35-80MM	12	406.10

OIL & FILTERS



MK-AUT-10012 CHAIN WRENCH

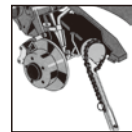

- For gripping round and irregular shaped items, tubes and piping.
- Ideal for oil filters, radiator caps and hub caps.
- Because it is compact. It allow operation on cylindrical parts in confined areas.
- It can be used in both directions without being removed.

ITEM CODE	DESCRIPTION	LENGTH (BODY)	LENGTH (CHAIN)	QTY/CTN	PRICE
MK-AUT-10012	Chain Wrenches	6"	20"	48	53.40

OIL & FILTERS



MK-AUT-10014 3 LEG OIL FILTER WRENCH



- Fits oil filters in sizes from 2- 1/2" to 4" (600mm-102mm) diameter.
- Use 1/2" or 3/8" square drive tool or 13/16" hex drive tool.

ITEM CODE	DESCRIPTION	QTY/CTN	PRICE
MK-AUT-10014	3 Leg Oil Filter Wrench	48	60.70

OIL & FILTERS



MK-AUT-10015 ECONOMIC STRAP OIL FILTER WRENCH*

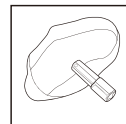

- Sockets type drive body with durable nylon strap reaches to tight areas.
- Removes filters up 4-3/4" (120mm).
- Use 1/2" square drive tool or 13/16" (21mm) spanner.

ITEM CODE	DESCRIPTION	QTY/CTN	PRICE
MK-AUT-10015	Economic Strap Oil Filter Wrench	120	26.80

ELECTRIC SYSTEM



MK-AUT-10016 PROFESSIONAL VACUUM & FUEL TESTER*

- Large 3-1/2" diameter gauge with color-coded easy-reading scales.
- Extra long heavy-duty rubber hose and 14mm/18mm manifold adapter.
- Checks for worn defective parts in fuel pumps, vacuum system.



ITEM CODE	DESCRIPTION	QTY/CTN	PRICE
MK-AUT-10016	Professional Vacuum & Fuel Tester	20	218.70

ENGINE



MK-AUT-10018 8 PCS AXLE SPINDLE RETHREADING SET*

- 8pcs thread restoring die set used to clean or repair axle threads on spindles of M24x1.50, M24x 2.00, M22x 1.00, M22x1.5, M20x1.5, M20x 1.25, 13/16" x 20 UNEF. Use with 1-1/4" socket or wrench.



ITEM CODE	DESCRIPTION	QTY/CTN	PRICE
MK-AUT-10018	8 Pcs Axle Spindle Rethreading Set	60	221.30

ENGINE



MK-AUT-10019 VALVE STEM SEAL PLIER*



- Long neck designed to reach into confined area of the seal to grip it for removal.
- Gripping serration in the tip allow them to group both original equipment and after market seals regardless of their configuration.

ITEM CODE	DESCRIPTION	QTY/CTN	PRICE
MK-AUT-10019	Valve Stem Seal Plier	20	92.20

TYRES



MK-AUT-10020 3-FUNCTION TIRE GAUGE



- Air inflator provides user with easy and controlled inflation. Cast in alloy body with H-D brass valves. With 3-1/2ft. Hose, with 3" pressure gauge, and easy-to-read.
- 0 to 220 psi 0 to 15 bar 0 to 15 kg/cm² 0 to 1500 kpa

ITEM CODE	DESCRIPTION	QTY/CTN	PRICE
MK-AUT-10020	3-Function Tire Gauge	12	193.50



TYRES



MK-AUT-10021 TIRE PRESSURE GAUGE



- Pressure 160lb/in², length 270mm
- Pressure 160lb/in², length 360mm

ITEM CODE	DESCRIPTION	QTY/CTN	PRICE
MK-AUT-10021	Tire Pressure Gauge	100	90.10

TYRES



MK-AUT-10022 TIRE AIR CHUCK



- 230MM
- 380MM

ITEM CODE	DESCRIPTION	QTY/CTN	PRICE
MK-AUT-10022-230	Tire Air Chuck	100	38.30

TYRES



MK-AUT-10024 MINIATURE PICK & HOOK SET



- Stainless steel points.
- Set contains awl, hook 45° & 90° bent tool.
- Use detail works and scribing, picking jobs.

ITEM CODE	DESCRIPTION	QTY/CTN	PRICE
MK-AUT-10024	Miniature Pick & Hook Set	200	45.90

ENGINE



MK-AUT-10025 VALVE SPRING COMPRESSOR KIT*



- Complets service tool kit for OHV & OHC petrol or diesel engines on Audi, Nissan, Toyota, Chrysler, Honda, Mazda, Mitsubishi, Porsche, Volvo, VW.

ITEM CODE	DESCRIPTION	QTY/CTN	PRICE
MK-AUT-10025	Valve Spring Compressor Kit	5	463.90

ENGINE



MK-AUT-10027 1/2"X M10 CYLINDER HEAD BOLT TOOL*



- The 100m length allows easy access to recessed head bolts.
- Comes with 1/2" drive for use with a torque wrench.
- Use for VW, AUDI cylinder head bolt.

ITEM CODE	DESCRIPTION	QTY/CTN	PRICE
MK-AUT-10027-6P	1/2" X M10 Cylinder Head Bolt Tool	60	27.70

ENGINE



MK-AUT-10028 UNIVERSAL HOSE CLAMP REMOVER*



- For replacement of fuel, oil and water hose.
- Hose clamp with flexible 600mm wire.
- Convenient for working hidden areas and long distance.
- Patent.

ITEM CODE	DESCRIPTION	QTY/CTN	PRICE
MK-AUT-10028	Universal Hose Clamp Remover	24	238.90

ENGINE



MK-AUT-10029 HOSE CLAMP PLIER*



- Keep wire clamps spread open and free both hands.
- Finger tip "position lock" makes it easy to replace the lower radiator hose.
- Fits more size clamps.

ITEM CODE	DESCRIPTION	QTY/CTN	PRICE
MK-AUT-10029	Hose Clamp Plier	50	76.80

ENGINE



MK-AUT-10031 HOSE REMOVER PLIER*



- For easy removal of 5/32" to 1/2" vacuum and fuel hoses. Engage the tube (line) with the black jaw.
- This sharpened jaw actually "DIGS" into the tube to grip it, squeeze and the hose is easily pushed off by the silver jaw.

ITEM CODE	DESCRIPTION	QTY/CTN	PRICE
MK-AUT-10031	Hose Remover Plier	50	55.80



ENGINE



MK-AUT-10032 OXYGEN SENSOR SOCKET*



- 1/2" Dr. 7/8" (2m/m) x 90mm long, 7mm slot for oxygen sensor on Japanese cars Ford, Chrysler & others cars.

ITEM CODE	DESCRIPTION	QTY/CTN	PRICE
MK-AUT-10032	Oxygen Sensor Socket	50	44.60

ENGINE



MK-AUT-10034 CLUTCH ALIGNER SET*



- Align single disc clutches on most vehicles, light truck & tractors.
- Properly aligns clutch plate by tapered cone fitting into pilot bushing or bearing.
- Size : 8 collects ranging from 0.465" (11mm) to 0.980" (24.9mm).

ITEM CODE	DESCRIPTION	QTY/CTN	PRICE
MK-AUT-10034	Clutch Aligner Set	20	165.90

ENGINE



MK-AUT-10036 UNIVERSAL PULLEY HOLDER*



- A professional tool set for balancer replacement.
- Built-in bearing makes balancer replacing job easy and damage-free.
- 4-slot puller plate plus 9 threaded adapters fit to balancers on most engines.

ITEM CODE	DESCRIPTION	QTY/CTN	PRICE
MK-AUT-10036	Universal Pulley Holder	20	154.00

ENGINE



MK-AUT-10039 UNIQUE COMPRESSION TESTER KIT



- Easy-reading 2-1/2" diameter gauge features color-coded quadruple calibrations with 0-300psi, 21kg/cm, 21 bar & 2100kpa.
- 13" durable rubber hose with 14mm/18mm adapter.
- 6" heavy-duty stem with universal rubber cone adapter fits all plug holes.

ITEM CODE	DESCRIPTION	QTY/CTN	PRICE
MK-AUT-10039	Unique Compression Tester Kit	24	194.30

ENGINE



MK-AUT-10033 HOSE REMOVER PLIER*



- Special JAWS design, one side is flexible to fix on the tube when using, the other side to pull out the hose.
- Hose range : 1/4" ~ 1/2".

ITEM CODE	DESCRIPTION	QTY/CTN	PRICE
MK-AUT-10033	Hose Remover Pliers	10	154.50

ENGINE



MK-AUT-10035 BALANCER PULLER & INSTALLER SET*



- A professional tool set for balancer replacement.
- Built-in bearing makes balancer replacing job easy and damage-free.
- 4-slot puller plate plus 9 threaded adapters fit to balancers on most engines.

ITEM CODE	DESCRIPTION	QTY/CTN	PRICE
MK-AUT-10035	Balancer Puller & Installer Set	6	518.20

ENGINE



MK-AUT-10038 SERPENTINE BELT TOOL*



- Releases tension on serpentine belts with spring loadedidler pulley.
- Four Sockets size : 13, 15, 16, 18mm.
- 1/2, 3/8 Dr.

ITEM CODE	DESCRIPTION	QTY/CTN	PRICE
MK-AUT-10038	Serpentine Belt Tool	12	110.50

STEERING & TRANSMISSION



MK-AUT-10041 UNIVERSAL BALL JOINT PULLER (Small Type)*



- Special steel for removing the ball pivots on steering arms, steering tie rods, steering knuckles, etc.
- Jaw open : 17mm.

ITEM CODE	DESCRIPTION	QTY/CTN	PRICE
MK-AUT-10041	Universal Ball Joint Puller (Small Type)	20	218.80



STEERING & TRANSMISSION



MK-AUT-10042 UNIVERSAL BALL JOINT PULLER (Big Type)*



- Special steel for removing the ball pivots on steering arms, steering tie rods, steering knuckles, etc.
- Jaw open : 20mm.

ITEM CODE	DESCRIPTION	QTY/CTN	PRICE
MK-AUT-10042	Universal Ball Joint Puller (Big Type)	20	218.80

STEERING & TRANSMISSION



MK-AUT-10044 BALL JOINT SEPARATOR*



- Tempered drop forged steel one piece construction for long & rough usage.
- 21/32" (18mm) Fork, 16" (410mm) length replaces worn out tie rods easily with hammer striking.
- Also can separate shock absorber links.

ITEM CODE	DESCRIPTION	QTY/CTN	PRICE
MK-AUT-10044	Ball Joint Separator	20	65.00

STEERING & TRANSMISSION



MK-AUT-10048 HUB SLIDE HAMMER PULLER*



- Pulls flange-type rear axles on most late model passenger cars & light trucks.
- Designed to fit axles with bolts & studs up to 9/16" dia.

ITEM CODE	DESCRIPTION	QTY/CTN	PRICE
MK-AUT-10048	Hub Slide Hammer Puller	1	362.40

TYRES



MK-AUT-10050 STEERING WHEEL PULLER SET*



- Two specialty pullers in one set including one flange type puller for removal of harmonic balancers, timing gear & other parts with two or three tapped holes. And a steering wheel, pulley & flywheel puller.

ITEM CODE	DESCRIPTION	QTY/CTN	PRICE
MK-AUT-10050	Steering Wheel Puller Set	10	428.40

STEERING & TRANSMISSION



MK-AUT-10043 SEAL PULLER*



- Removes Oil & grease seals.
- Two tips fit most application.

ITEM CODE	DESCRIPTION	QTY/CTN	PRICE
MK-AUT-10043	Seal Puller	50	92.00

TYRES



MK-AUT-10047 FRON AXLE



- Use the extension and adjustable wire to clip the axle tightly.
- Pull out with the slide hammer easily.

ITEM CODE	DESCRIPTION	QTY/CTN	PRICE
MK-AUT-10047	Front Wheel Driver Axle Puller	2	679.60

STEERING & TRANSMISSION



MK-AUT-10049 HUB SLIDE HAMMER PULLER*



- Pulls 4 bolts front hub easily with the 10 lb slide hammer.
- Heavy duty tool for rugged jobs.

ITEM CODE	DESCRIPTION	QTY/CTN	PRICE
MK-AUT-10049	Hub Slide Hammer Puller	2	380.50

UNDERCAR SERIES



MK-AUT-10051 INNER TIE ROD TOOLS SET*



- Works on the inner tie rods with inaccessible wrench flats.
- Many inner tie rod end sockets do not have a complete hex on the full length of the socket. The rounded socket ends prevent access to the wrench flats. Seven crows feet, sizes 1- 3/16", 1-1/14", 1-5/16, 1-7/16", 14mm 17mm and 33.6mm, to engage the wrench flats. The long socket then slips over the tie rod end and connects to the crows foot.

ITEM CODE	DESCRIPTION	QTY/CTN	PRICE
MK-AUT-10051	Inner Tie Rod Tools Set	1	410.10



UNDERCAR SERIES



MK-AUT-10052 MULTI-PURPOSE INNER TIE ROD TOOL



- The Master tie rod tools easily replaces inner tie rod end, without removing the rack & pinion.
- Capacity : 33-42mm.
- Patented.

ITEM CODE	DESCRIPTION	QTY/CTN	PRICE
MK-AUT-10052	Multi-Purpose Inner Tie Rod Tool	36	281.20

SUSPENSIONS



MK-AUT-10054 UNIVERSAL HUB PULLER SET*



- Readily adjustable sliding legs to pull wheel hubs more quicker & easier where the bolt circle does not exceed 7-1/2"(190.2mm), also removes press-fit rear brake drums.
- Striking handle & puller screw included.
- Special designed to use on most model of car.

ITEM CODE	DESCRIPTION	QTY/CTN	PRICE
MK-AUT-10054	Universal Hub Puller Set	5	502.00

UNDERCAR SERIES



MK-AUT-10057 UNIVERSAL AXLES SLIDE HAMMER SET*



- Increased the coverage with the two axle pullers.
- Works together with other tools is more easy.
- Included 3-jaw puller and many types of joint.

ITEM CODE	DESCRIPTION	QTY/CTN	PRICE
MK-AUT-10057	Universal Axles Slide Hammer Set	2	533.50

UNDERCAR SERIES



MK-AUT-10060 HYDRAULIC BEARING SEPARATOR PULLER SET*



- Bearing separator MK-10005 (4"-6") inside.
- Effore-saving with the hydraulic screw.
- Pullout the bearing with the H-type beam and bolts.
- For removing bearings, gears, sprockets and bushes, 10 ton capacity hydraulic ram with tommy bar, metal storage case.

ITEM CODE	DESCRIPTION	QTY/CTN	PRICE
MK-AUT-10060	Hydraulic Bearing Separator Puller Set	1	1,161.60

UNDERCAR SERIES



MK-AUT-10053 ANGLE LOCATOR*



- Use the nuts under the tool to change the angle.
- With the magnet used to put on the tools when you are working.
- Use with 1840 or 1002 is better.

ITEM CODE	DESCRIPTION	QTY/CTN	PRICE
MK-AUT-10053	Angle Locator	12	246.80

BRAKES



MK-AUT-10055 BLIND HOLE BEARING PULLER SET*



- One slide hammer assemble & 4 clamp.
- Attachments for 3/8" to 1/2" (10-14mm), 9/16" to 11/16" (15-19mm), 5/8" to (18-25mm) & 1" to 1-1/4" (25-32mm) I.D. Bearings' pulling.
- Open clamps by turning handle clockwise to snug against the bearing for pulling out evenly without damage the parts.

ITEM CODE	DESCRIPTION	QTY/CTN	PRICE
MK-AUT-10055	Blind Hole Bearing Puller Set	5	869.40

UNDERCAR SERIES



MK-AUT-10058 HYDRAULIC GEAR PULLER SET*



- For agriculture machine, automotive, and industry use.
- Hydraulic ram included for laborsaving.
- Material: SCM415 hardened 40° ~ 50°.
- Packing: carrying case. 1 set/ 16kgs 17kgs/ 1.2'.

ITEM CODE	DESCRIPTION	QTY/CTN	PRICE
MK-AUT-10058	Hydraulic Gear Puller Set	1	1,247.40

UNDERCAR SERIES



MK-AUT-10061 HYDRAULIC BEARING SEPARATOR PULLER SET*



- To use MK-10005 (6"-8") together is better.
- Pullout the bearing with the H-type beam and bolts.

ITEM CODE	DESCRIPTION	QTY/CTN	PRICE
MK-AUT-10061	Hydraulic Bearing Separator Puller Set	1	1,482.80



BRAKES



MK-AUT-10063 BRAKE SPRING COMPRESSOR*



- BIG WINDOW designed for great visibility during operation.
- Allow fast & easy removal & replacement of brake shoe hold-down springs.

ITEM CODE	DESCRIPTION	QTY/CTN	PRICE
MK-AUT-10063	MK-10063 Brake Spring Compressor	10	63.00

BRAKES



MK-AUT-10064 BRAKE SPRING TOOL*



- Hook the brake return spring and screw-up to lock it for removal & installation.
- A smart tool service those brake that don't use anchor pins.

ITEM CODE	DESCRIPTION	QTY/CTN	PRICE
MK-AUT-10064	Brake Spring Tools	10	40.30

BRAKES



MK-AUT-10065 BRAKE SPRING PLIER*



- Tool easily removes and installs shoe return springs on most drum brakes.
- Socket end removes spring from anchor stud and notched end install spring on anchor.
- Tool is chrome plated to resist rust and provide easy clear-up.

ITEM CODE	DESCRIPTION	QTY/CTN	PRICE
MK-AUT-10065	Brake Spring Pliers	1	57.30

BRAKES



MK-AUT-10066 BRAKE SPRING PLIER*



- For removing and replacing brake springs of drum type brake.
- Claw on jaw is replaceable.

ITEM CODE	DESCRIPTION	QTY/CTN	PRICE
MK-AUT-10066	Brake Spring Pliers	12	305.00

BRAKES



MK-AUT-10067 HEADLIGHT ADJUSTING & BREAK SPRING HOOK*



- This tool made from heat treated alloy steel is specially designed for removing and specially designed for removing and installing hard-to-reach headlight adjusting spring. OAL 6"

ITEM CODE	DESCRIPTION	QTY/CTN	PRICE
MK-AUT-10067	Headlight Adjusting & Brake Spring Hook	1	33.30

TYRES



MK-AUT-10068 SNAP IN TIRE VALVE INSTALLER*



- Steel constructed tool deep threaded for positive sealing of all snap-in type passenger car tire valve stems.
- Rubber cover design to protect the rim.
- 3 position settled.
- Patented.

ITEM CODE	DESCRIPTION	QTY/CTN	PRICE
MK-AUT-10068	Snap In Tire Valve Installer	10	62.80

TYRES



MK-AUT-10069 ROLLER STITCHER*



- Durable steel handle.
- Bearing inside for using easier.

ITEM CODE	DESCRIPTION	QTY/CTN	PRICE
MK-AUT-10069	Roller Stitcher	1	105.60

UNDERCAR
SERIES



MK-AUT-10070 PITMAN ARM PULLER*



- Heavy duty forged alloy steel yoke.
- Heated treated center screw.
- Remove tie rod ends pitman arm assemblies from many light trucks.
- Opening size: 27mm.
- Pull travel: 45mm

ITEM CODE	DESCRIPTION	QTY/CTN	PRICE
MK-AUT-10070	Pitman Arm Puller	30	124.20



UNDERCAR SERIES



MK-AUT-10071 PITMAN ARM PULLER*



- Heavy duty forged alloy steel yoke.
- Removes tie rod ends pitmans arm assemblies from many cars light trucks.
- Opening size : 33mm
- Pull travell : 64mm

ITEM CODE	DESCRIPTION	QTY/CTN	PRICE
MK-AUT-10071	Pitman Arm Puller	1	163.30

UNDERCAR SERIES



MK-AUT-10072 OUTER TIE ROD REMOVER*



- Two adjustable jaws special designed for removing most model of outer tie rod.
- Material : SCM420 Hardener 42°
- Packing: each/ double blister.
6 sets / 24sets / 29kgs / 30kgs / 2.3'

ITEM CODE	DESCRIPTION	QTY/CTN	PRICE
MK-AUT-10072	Outer Tie Rod Remover	1	218.00

UNDERCAR SERIES



MK-AUT-10073 ADJUSTABLE WHEEL BEARING LOCK NUT WRENCH SET*



- Adjustable jaws with locking feature to suit both hexagon & octagon wheel bearing lock nuts.
- Includes three sets of pinsto suit lock nuts with pin holes.



- Capacity : 6PT lock nuts : 1-3/4"to 5-3/4"(49-135mm)
8PT lock nuts : 1-3/4"to5-5/8" (49-143mm)
Pin diameters:1/4"(6mm), 5/16"(8mm), 3/8"(10mm)

ITEM CODE	DESCRIPTION	QTY/CTN	PRICE
MK-AUT-10073	Adjustable Wheel Bearing Lock Nut Wrench Set	1	1,050.00

ELECTRIC SYSTEM



MK-AUT-10075 BATTERY TESTER*

- Deluxe type and more function such as starter motor load, dynamo condition, individual load current.
- Suitable capacity of battrries 18-200 AH 12V (24V)



ITEM CODE	DESCRIPTION	QTY/CTN	PRICE
MK-AUT-10075	Battery Tested	1	2,179.40

UNDERCAR SERIES



MK-AUT-10075A HEAVY-DUTY MANUAL OPERATED GREASE GUN SERIES (LEVER TYPE)

- Heavy-duty construction for professional operation and home users. Ideal for machine, automobile, farm and garden equipments recreation vehicles etc.
- High pressure out put performance top quality grease gun series.

Capacity	Cartridge Loading	14 oz.
	Bulk Loading	400 c.c.
Size	mm L x mmø	370 x 56.4
	Standard Processing	Chrome Plated
Pressure Tested	Working Pressure	4500 psi/310 bar
	Burst Pressure	10000 psi/690 bar



ITEM CODE	DESCRIPTION	QTY/CTN	PRICE
MK-AUT-10075A	Heavy-Duty Manual Operated Grease Gun Series	16	102.70

ELECTRIC SYSTEM



MK-AUT-10076 CAR BATTERY & ALTERNATOR CHECKED

- Led lights indicate car battery condition (engine stop) or output of alternator (engine running).
- Lights slow poor, fair or good condition.
- Magnetic backboard keeps your hands free for checking.



ITEM CODE	DESCRIPTION	QTY/CTN	PRICE
MK-AUT-10076	Car Battery & Alternator Checked	100	58.60

ELECTRIC SYSTEM



MK-AUT-10077 BATTERY CARRIER*



- Designed to protect soft-sided, sealed life time batteries.
- Padded rubber and grooved for better grip for battery.
- Vinly handle for easy lift and carry.
- Fits all 4" to 7" (102mm-178mm) batteries, including side post batteries.

ITEM CODE	DESCRIPTION	QTY/CTN	PRICE
MK-AUT-10077	Battery Carrier	24	65.80

ELECTRIC SYSTEM



MK-AUT-10078 ELECTRIC CIRCUIT TESTER

- Sharp prove tip covered with brass protection cap, check function of car lights faster and easier.
- Check reange: 6-12, 24v.



ITEM CODE	DESCRIPTION	QTY/CTN	PRICE
MK-AUT-10078	Electric Circuit Tester	200	21.20



ELECTRIC SYSTEM



MK-AUT-10079 ELECTRIC CIRCUIT TESTER

- Power on type test 6, 12, 24 volt circuits.
- For wire breaks, short, fuses, lamps, relay armatures, etc.
- 4" inspection probe with point cover.
- 36" long 16-gauge wire with alligator clip.



ITEM CODE	DESCRIPTION	QTY/CTN	PRICE
MK-AUT-10079	Electric Circuit Tester	100	47.80

ELECTRIC SYSTEM



MK-AUT-10081 A/C SPRING LOCK COUPLING TOOLS*



- Used on 1981 th current Ford cars and pickups having spring lock connection on the A/C system.
- For 3/8", 1/2", 5/8" and 3/4" couplers.

ITEM CODE	DESCRIPTION	QTY/CTN	PRICE
MK-AUT-10081	A/C Spring Lock Coupling Tools	12	66.00

ELECTRIC SYSTEM



MK-AUT-10082 A/C COMPRESSOR CLUTCH REMOVER KIT*



- Replace clutches found on FS6, C171, 6P & 148 Computer.
- Also GM R4 & A6, HR-6, DA-6 & V5 A/C compressor.
- And compressors of sanden SD505, 507, 508, 510, 575, 708 and 709.
- 2 & 3 hole puller plate fits most clutches, the mechanical force does the pulling job.

ITEM CODE	DESCRIPTION	QTY/CTN	PRICE
MK-AUT-10082	A/C Compressor Clutch Remover Kit	12	364.00

TYRES



MK-AUT-10083 VALVE CORE REMOVER/ INSTALLER TOOL*



- For installation and remover of standard valve cores.
- Has a screwdriver-style handle.
- Tip diameter: 5.5mm.
- Tip length: 60mm.

ITEM CODE	DESCRIPTION	QTY/CTN	PRICE
MK-AUT-10083	Valve Core Remover/Installer Tool	100	6.70

BRAKES



MK-AUT-10084 8PCS PIN PUNCH SET

- The cylindrical shank, with ultra-fine tolerances is perfectly smooth to ensure a high degree of toughness.
- Content: 1.6, 2.3, 3.2, 4.0, 4.8, 5.5, 6.4 & 8.0mm.

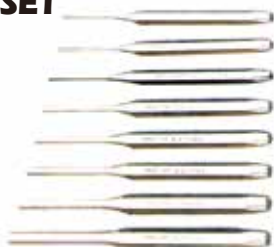

ITEM CODE	DESCRIPTION	QTY/CTN	PRICE
MK-AUT-10084	8pc Pin Punch Set	36	111.10

BRAKES



MK-AUT-10087 METRIC RETHREADER SET*



- Contains: seven metric rethreader dies. seven metric rethreader taps. Seven metric thread file.
- Rethreader dies and taps size: 6x1.00, 8.1.25, 10x1.25, 10x1.50, 12.1.25, 12x1.50, 12x1.75.
- File size: 0.75, 1.00, 1.25, 1.50, 1.75, 2.00, 2.50, 3.00

ITEM CODE	DESCRIPTION	QTY/CTN	PRICE
MK-AUT-10087	Metric Rethreader Set	12	218.00

ENGINE



MK-AUT-10088 LEAK-CHECK*



- Sports and locates combustion leaks quickly in cracked or warped heads, leaky gaskets or cracked block. Use Leak-Check in the radiator opening with engine idling. The blue test liquid will turn into yellow in 60 seconds if there is a combustion leak, no matter how small. Get exact location of leak by disconnecting one spark plug at a time and retesting. Completely accurate proof of leak.
- Direct or use with 1005 is better.
- 250cc fluid container.
- Patented.

ITEM CODE	DESCRIPTION	QTY/CTN	PRICE
MK-AUT-10088	Leak-Check	10	488.30

UNDERCARR SERIES



MK-AUT-10089 STEERING WHEEL REMOVER / LOCK PLATE COMPRESSOR SET



- Removing steering wheels of most vehicles, with or without telescoping tilt steering columns is easy with this new set.
- The steering wheel lock plate compressor is also included, to compress the steering wheel lock plate to remove or install the snap ring.

ITEM CODE	DESCRIPTION	QTY/CTN	PRICE
MK-AUT-10089	Steering Wheel Remover/Lock Plate Compressor Set	10	284.30



ENGINE



MK-AUT-10090 MECHANIC'S STETHOSCOPE

- Provides a fast and easy way to locate noises in engines or bearing and other moving parts.
- Aluminium alloy probe/needle for finding the exact location of specific noises.
- Instrument is shockproof.
- Ideal for pinpointing unusual vibration or suspected leaks (valves, piston ring, gaskets. etc)



ITEM CODE	DESCRIPTION	QTY/CTN	PRICE
MK-AUT-10090	Mechanic's Stethoscope	48	94.70

BODY



MK-AUT-10094 EXTRA LARGE SLIDING HAMMER SET*



- For different extent of indentation, it has five hooks attached.
- The hooks will complete fit kinds of plate to fix your problem.
- It is a durable and made by steel.

ITEM CODE	DESCRIPTION	QTY/CTN	PRICE
MK-AUT-10094	Extra Large Sliding Hammer Set	2	645.80

ENGINE



MK-AUT-10096 T-TYPE SCREWDRIVER*

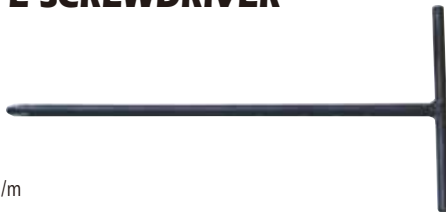

- Size : #1, #2 & #3 x 8m/m
- Full length : 250mm

ITEM CODE	DESCRIPTION	QTY/CTN	PRICE
MK-AUT-10096A	T-Type Screwdriver-#1	200	15.90
MK-AUT-10096B	T-Type Screwdriver-#2	200	15.90
MK-AUT-10096C	T-Type Screwdriver-#3	200	15.90

BODY



MK-AUT-10098 CLAMP ANCHOR BASE*



- Use with 5/16" and 3/8" chains.
- Install on the top of model 8P102.

ITEM CODE	DESCRIPTION	QTY/CTN	PRICE
MK-AUT-10098	Clamp Anchor Base	10	180.60

ELECTRIC SYSTEM



MK-AUT-10093 BATTERY HYDROMETER



- Tests the battery in seconds.
- Color-coded float for easy reading.

ITEM CODE	DESCRIPTION	QTY/CTN	PRICE
MK-AUT-10093	Battery Hydrometer	100	19.70

MK-AUT-10095 FLEXIBLE SHAFT NUT SPINNER*



- Round, flexible blade, fit for hexagon headed bolt, nuts screws and hose clamp.

ITEM CODE	DESCRIPTION	QTY/CTN	PRICE
MK-AUT-10095-1/4	1/4"	100	28.80
MK-AUT-10095-06MM	6mm	100	28.80
MK-AUT-10095-08MM	8mm	100	28.80

BODY



MK-AUT-10097 LARGE SLIDING HAMMER SET*



- Include every kind of hooks and pullers to fit.
- Hooks made by plate for easy work when operator use it in confined space.

ITEM CODE	DESCRIPTION	QTY/CTN	PRICE
MK-AUT-10097	Large Sliding Hammer Set	2	477.50

BODY



MK-AUT-10100 SMALL MOUTH PULL CLAMP (TWO-WAY)*



- Capacity: 5 ton(straight way)
2 ton(cross way)
- Bolt size: 13m/mø x 70m/ml
- Two-way pull operation.
- 12pcs/ 26/ 27/ 1".

ITEM CODE	DESCRIPTION	QTY/CTN	PRICE
MK-AUT-10100	Small Mouth Pull Clamp (Two-Way)	6	360.60



BODY MK-AUT-10102 BOX CLAMP*

- Capacity: 3 ton
- Single-way pull operation.
- Both side's jaws are different in order to fit the confined room.
- Bolt size: 14m/mø x 110 L m/m.
- 12pcs/ 25/ 26/ 1".



ITEM CODE	DESCRIPTION	QTY/CTN	PRICE
MK-AUT-10102	Box Clamp	6	342.50



BODY MK-AUT-10103 BOX CLAMP (TWO-WAY)*

- Capacity: 3 ton(straight way)
2 ton(cross way)
- Two-way pull operation.
- Both side's jaw are different in order to fit the confined room.
- Both size: 14mmø x 110m/mL.
- 12pcs/ 27/ 28/ 1'.



ITEM CODE	DESCRIPTION	QTY/CTN	PRICE
MK-AUT-10103	Box Clamp (Two-Way)	5	385.70



BODY MK-AUT-10105 AUTOMATIC WELDING SLIDE HAMMER*



- Full lenght: 435mm.
- Connect the positive handle of welding machine into the connector.
- To weld slide the hammer at the same time.

ITEM CODE	DESCRIPTION	QTY/CTN	PRICE
MK-AUT-10105	Automatic Welding Slide Hammer	10	286.40



BODY MK-AUT-10106 SLIDE HAMMER HOOK SET*



- Full lenght: 435mm.
- To pull out the washer which welding in the indentation.

ITEM CODE	DESCRIPTION	QTY/CTN	PRICE
MK-AUT-10106	Slide Hammer Hook Set	10	234.20

MK-AUT-10109 40PCS POWER BIT SET



- Material: S2

CONTENTS:
• 7pcs 30mm star power bit: T20, T25, T30, T40, T45, T50, T55.
• 7pcs 75mm star power bit: T20, T25, T30, T40, T45, T50, T55.
• 7pcs 30mm hex power bit: 4, 5, 6, 7, 8, 10, 12mm.
• 7pcs 75mm hex power bit: 4, 5, 6, 7, 8, 10, 12mm.
• 5pcs 30mm spline power bit: M5, M6, M8, M10, M12.
• 5pcs 75mm spline power bit: M5, M6, M8, M10, M12.
• 1pc 10mm (hex) x 3/8" Dr. Adapter.
• 1pc 10mm (hex) x 1/2" Dr. Adapter.

ITEM CODE	DESCRIPTION	QTY/CTN	PRICE
MK-AUT-10109	40pc Power Bit Set	10	177.30



BODY MK-AUT-10107 GLASSES RUBBER KNIFE*



- Many wind shields, back glasses and side glasses can be removed with the knife.
- Quick and easy to use.

ITEM CODE	DESCRIPTION	QTY/CTN	PRICE
MK-AUT-10107	Glasses Rubber Knife	48	69.60



BODY MK-AUT-10108 4PCS PRY BAR SET



- Spec: 7/16" x 24"L, 7/16" x 18"L, 3/8" x 12" L, 1/4 x 8".

ITEM CODE	DESCRIPTION	QTY/CTN	PRICE
MK-AUT-10108	4pcs Pry Bar Set	12	135.20

MK-AUT-10110 EXTRA LONG EXTENSION BAR*



- Strong, chrome plated steel drive extensions.
- Extends ratchet from fastener for more freedom of ratchet movement.
- Chrome-vanadium steel.

ITEM CODE	DESCRIPTION	QTY/CTN	PRICE
MK-AUT-10110A	1/4" Dr. x 14"	100	44.70
MK-AUT-10110B	3/8" Dr. x 18"	100	64.60
MK-AUT-10110C	1/2" Dr. x 24"	100	99.40



MK-AUT-10111 ADJUSTABLE UNIVERSAL CAMSHAFT PULLEY HOLDING TOOL*



- For use on all kinds of engines.
- This wrench is designed with grooved pins which are designed hold the camshaft pulley stationary while loosening and tightening the center shaft bolt.
- While useful on most asian overhead cam engines, it is most needed on transverse mounted V6 engines such as the VG30 used in Nissan Maximas, as well as, the 3VFE and 1MZFE engines used in Toyota Camrys.
- Application : Benz, BMW, Ford, Mitsubishi, Honda, VW, Audi, Nissan, Volvo, Toyota, etc.
- Adjustable Distance : P.C.D. 21mm - 100mm
- NW : 0.99kgs GW : 1.01kgs

ITEM CODE	DESCRIPTION	QTY/CTN	PRICE
MK-AUT-10111	Adjustable Universal Camshaft Pulley Holding Tool	7	479.50

MK-AUT-10113 BENZ ENGINE OIL LEVEL GAUGE (STRAIGHT)*



- Engine Type: 103, 943, 984/985, 104, 111, 119, 120, 604, 605, 606, 611, 612, 613, 628, 965, 137, 603, 913/963/97
- Remark: Volute
- Dipstick for determining oil level and inspecting length of dipstick guide tube.

ITEM CODE	DESCRIPTION	QTY/CTN	PRICE
MK-AUT-10113	Benz Engine Oil Level Gauge (Straight)	60	318.00

MK-AUT-10119 HOSE REMOVER SET*



- Special designed to remove the hose easily.
- 1/2 sets/72 sets/15.5 kgs/16.5 kgs/2.6'.

ITEM CODE	DESCRIPTION	QTY/CTN	PRICE
MK-AUT-10119	Hose Remover Set	60	39.80

MK-AUT-10112 3/8" DELUXE CROWS-FOOT WRENCH SET*



- Contents : 10, 11, 12, 13, 14, 15, 16, 17, 18, 19, 20mm.
- Made from Chrome-Molybdenum steel with a gap for use on union nuts fitted in hydraulic, oil diesel injection and compressed air systems.

ITEM CODE	DESCRIPTION	QTY/CTN	PRICE
MK-AUT-10112	3/8" Deluxe Crows-Foot Wrench Set	1	170.80

MK-AUT-10117 VALVE ADJUSTING TOOL*

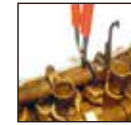

- Full length : 1239B (155mm)
- Designed to adjust brakes on most cars and light trucks.
- Universal angle design for most cars

ITEM CODE	DESCRIPTION	QTY/CTN	PRICE
MK-AUT-10117	Valve Adjusting Tools	60	304.50

MK-AUT-10118 VALVE ADJUSTING TOOL*



- For overhead camshaft engines using spacer shims.
- This unique tool has been designed to allow for easy valve adjustment on all NISSAN'S, and many other overhead camshaft engines using spacer shims for valve adjustment in operation.

ITEM CODE	DESCRIPTION	QTY/CTN	PRICE
MK-AUT-10118	Valve Adjusting Tools	60	278.00

MK-AUT-10120 OXYGEN SENSOR SOCKET*

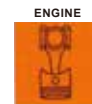

- 3/8" Dr. 7/8 (22m/m) x .

ITEM CODE	DESCRIPTION	QTY/CTN	PRICE
MK-AUT-10120	Oxygen Sensor Socket	20	38.20



MK-AUT-10121 ALL STEEL BENCH VISE



- Large anvil and 360° swivel base.
- Jaws made with the body for economy cost.
- Jaw with: 6"
- Maximum opening: 6"

ITEM CODE	DESCRIPTION	QTY/CTN	PRICE
MK-AUT-10121	All Steel Bench Vise	1	710.40

MK-AUT-10123 BENZ ASSEMBLY SLEEVE FOR IGNITION*



- For removal and replacement of the ignition switch retaining ring fitted to Mercedes types W129 W140 W202 W210 W220.
- NW : 0.06kgs

ITEM CODE	DESCRIPTION	QTY/CTN	PRICE
MK-AUT-10123	Benz Assembly Sleeve For Ignition	60	190.70

MK-AUT-10125 BENZ DASHBOARD SERVICE TOOLS KIT*



- Kit includes ignition lock remover, radio set remover, and instrument cluster removing hooks.
- NW : 0.2kgs

ITEM CODE	DESCRIPTION	QTY/CTN	PRICE
MK-AUT-10125	Benz Dashboard Service Tool Kit	1	158.90

MK-AUT-10128 BALL PEN/POINTER WITH POCKET CLIP*



- Chromed metal body with pocket-clip for safe storage powerful magnet with 1.0kg capacity.

ITEM CODE	DESCRIPTION	QTY/CTN	PRICE
MK-AUT-10128	Ball Pen / Pointer with Pocket Clip	200	29.00

MK-AUT-10122 CAST STEEL SWIVEL BENCH VISE



- Bench mounting, heavy-duty vice with cast iron body and replaceable, serrated steel jaws smooth rolled thread for accurate clamping.

Item Code	Jaw Width	Max. Opening	Weight	Qty /Ctn	Price
MK-AUT-10122-04	4"	4"	1PC/CTN/7.5KGS/ 8.3KGS/0.4'	1	501.60
MK-AUT-10122-05	5"	5"	1PC/CTN/11KGS/ 12KGS/0.6'	1	638.30
MK-AUT-10122-06	6"	6"	1PC/CTN/14.5KGS/ 16KGS/0.8'	1	811.30
MK-AUT-10122-08	8"	8"	1PC/CTN/20.5KGS/ 22KGS/1.2'	1	1,067.00
MK-AUT-10122-10	10"	10"	1PC/CTN/25.6KGS/ 26.9KGS/1.5'	1	1,504.80

MK-AUT-10124 BALL PIVOT*



- Install under the model 8P102.
- This tool helps operator flexible use model 8P102.

ITEM CODE	DESCRIPTION	QTY/CTN	PRICE
MK-AUT-10124	Ball Pivot	100	119.50

MK-AUT-10126 COOLING SYSTEM TESTERS*



- Test cooling system for leaks.
- Includes hand pump.
- Test head in a black blow mold case.
- Suitable for : Nissan, Mitsubishi, Mazda, Subaru, Toyota, Renault, Fiat, GM, Chrysler, VW, Audi, Volvo, Saab, Mercedes Benz, BMW, Peugeot, Jeep, Rover, Citroen, Truck.
- NW : 4kgs.

ITEM CODE	DESCRIPTION	QTY/CTN	PRICE
MK-AUT-10126	Cooling System Testers	5	1,186.80

MK-AUT-10129 FLEXIBLE MAGNETIC BAR



- Flexible shaft bends & hold... in all positions.
- Long & slender shaft for easy access to confined areas.
- Comfort-grip handle.
- 20" (510mm) OAL.

ITEM CODE	DESCRIPTION	QTY/CTN	PRICE
MK-AUT-10129	Flexible Magnetic Bar	48	31.90



MK-AUT-10130 FLEXIBLE ROD WITH MAGNETIC TIP



- Strong shaft bends & holds in all position.
- Magnetic capacity : 1.6 kgs (3.5lbs).
- comfortable handle 23-1/2" (600mm) OAL.

ITEM CODE	DESCRIPTION	QTY/CTN	PRICE
MK-AUT-10130	Flexible Rod With Magnetic Tip	100	50.50

MK-AUT-10133 MAGNETIC NUT SETTER



- For hex head screws, bolts and nuts.
- Compatible with impact drill/driver.
- Fits all brand.

ITEM CODE	DESCRIPTION	QTY/CTN	PRICE
MK-AUT-10133-008	8mm x 42mm	100	7.50
MK-AUT-10133-010	10mm x 45mm	500	7.50
MK-AUT-10133-012	12mm x 45mm	500	7.50

MK-AUT-10135 3 PCS SCRAPER KNIFE SET

- Wood handle.
- Stainless steel.
- Ideal for remove gasket blade.



ITEM CODE	DESCRIPTION	QTY/CTN	PRICE
MK-AUT-10135	3 pcs Scraper Knife Set	80	112.70

MK-AUT-10136 BENZ BUSH REMOVER / INSTALLER SET*



- Removal and replacement tool for metallic bushes on rear axles Mercedes type 201 / 124 / 202 / 140 / 129 / 210 the tool incorporates an axial bearing and also incorporates a pressure piece which guarantees the correct position of the new metallic bushes when replaced.
- NW:1.68kgs

ITEM CODE	DESCRIPTION	QTY/CTN	PRICE
MK-AUT-10136	Benz Bush Remove / Installer Set	10	792.00

MK-AUT-10132 DEEP HOLE NUT SETTER*



- For hex head screws, bolts and nuts.
- Compatible with impact drill/driver.
- Fits all brand.

ITEM CODE	DESCRIPTION	QTY/CTN	PRICE
MK-AUT-10132-008	8mm X 100mm	500	13.80
MK-AUT-10132-010	10mm X 100mm	500	13.80
MK-AUT-10132-012	12mm X 100mm	300	14.20
MK-AUT-10132-014	14mm X 100mm	300	15.80

MK-AUT-10134 OIL FILTER SOCKET



- Use with 1/2" Dr. tool or 21mm wrench.
- Cup type filter wrenches, made from 7 and 16 gauge steel and can withstand like sockets thereby minimising the possibility of crushing filters.

ITEM CODE	DESCRIPTION	QTY/CTN	PRICE
MK-AUT-10134-064	64mm	100	44.20
MK-AUT-10134-067	67mm	100	44.20
MK-AUT-10134-073	73mm	100	44.20
MK-AUT-10134-074	74mm	100	44.20
MK-AUT-10134-079	79mm	100	44.20
MK-AUT-10134-084	84mm	100	44.20
MK-AUT-10134-086	86mm	100	44.20
MK-AUT-10134-089	89mm	100	48.00
MK-AUT-10134-091	91mm	100	48.00
MK-AUT-10134-092	92mm	100	48.00
MK-AUT-10134-095	95mm	100	48.00
MK-AUT-10134-101	101mm	100	48.00

MK-AUT-10137 BENZ TRANSMISSION OIL LEVEL GAUGE*



- The tool is designed to measure the oil level of transmission.

ITEM CODE	DESCRIPTION	QTY/CTN	PRICE
MK-AUT-10137	Benz Transmission Oil Level Gauge	60	189.60

MK-AUT-10138 TRANSMISSION DEPTH GAUGE*

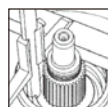

- Place the parallel rest on transmission housing. Using the depth gauge, measure from the parallel rest to the parking gear.
- Using the depth gauge, measure from the parallel rest to the contact surface of the deep-groove ball bearing in the transmission housing.

ITEM CODE	DESCRIPTION	QTY/CTN	PRICE
MK-AUT-10138	Transmission Depth Gauge	40	824.90



MK-AUT-10139
AIR BLOW GUNS FOR PROFESSIONALS
(Brass Air Inlet)



- For auto/motorcycle maintenance, woodworking, decorative works, machines, production lines and home use.

ITEM CODE	DESCRIPTION	QTY/CTN	PRICE
MK-AUT-10139-100	4" Air Blow Guns	60	29.60

MK-AUT-10140
600AMP ELECTRODE WELDING HOLDER



- Special high quality of unbreakable material for Buck Moulding Compound and Vulcanized Fiber Tube. The Vulcanized Fiber are also able to with a very high temperature.

ITEM CODE	DESCRIPTION	QTY/CTN	PRICE
MK-AUT-10140	600 Amp Electrode Welding Holder	50	61.70

MK-AUT-10141 LIGHT SHRINKING
HAMMER WITH WOODEN HANDLE



- Drop forged steel with proper heat treatment for extra durability and strength
- Polished striking head and face
- Milled round face, Flat square face
- Hickory handle for nice feel and balance

ITEM CODE	HEAD WGT	O/L	QTY/CTN	PRICE
MK-AUT-10141	400 G	300	36	38.60

MK-AUT-10142 LIGHT SHRINKING
HAMMER WITH WOODEN HANDLE



- Drop forged steel with proper heat treatment for extra durability and strength
- Polished striking head and face
- Milled square face, Flat round face
- Hickory handle for nice feel and balance

ITEM CODE	HEAD WGT	O/L	QTY/CTN	PRICE
MK-AUT-10142	400 G	300	36	38.60

MK-AUT-10143 CURVED PEIN AND
FINISHING HAMMER WITH WOODEN
HANDLE



- Drop forged steel with proper heat treatment for extra durability and strength
- Polished striking head and face
- Possess one end for driving masonry chisel and a curved blade with beveled edge for chipping mortar and trimming bricks to size

ITEM CODE	HEAD WGT	O/L	QTY/CTN	PRICE
MK-AUT-10143	400 G	300	36	42.30

MK-AUT-10180
7PCS AUTO BODY
REPAIR TOOL SET



- Seven of the most common tools necessary for professional body work are included in this set: D1016, D1017, D1019, D1785, D1786 and D1787 apply,

ITEM CODE	DESCRIPTION	QTY/CTN	PRICE
MK-AUT-10180	7pcs Auto Body Repair Tool Set	4	846.30

MK-AUT-10179
40 PCS TAP
WRENCHES SET*



1/2" DRIVER
TAP M3X0.5, M3X0.6, M4X0.7, M4X0.75, M5X0.8, M5X0.9, M6X0.75, M6X1.0, M7X0.75, M7X1.0, M8X1.0, M8X1.25, M10X1.25, M10X1.5, M12X1.5, M12X1.75, 1/8NPT27
DIE M3X0.5, M3X0.6, M4X0.7, M4X0.75, M5X0.8, M5X0.9, M6X0.75, M6X1.0, M7X0.75, M7X1.0, M8X1.0, M8X1.25, M10X1.25, M10X1.5, M12X1.5, M12X1.75, 1/8NPT27
TAP WRENCH M3-M12
"T"TYPE TAP WRENCH
DIE STOCK 25MM
SCREWDRIVER
SCREW PITCH GAUGE
BLOW CASE

ITEM CODE	DESCRIPTION	QTY/CTN	PRICE
MK-AUT-10179	40 pcs Tap Wrenches Set	10	331.30



MK-AUT-10249 **TWO WAY OIL FILTER WRENCH**

- The tool is used for remove and install the oil filter
- Use with Dr.1/2" or 21 mm wrench.
- Size: range 60-80 mm.



MK-AUT-10250 **TWO WAY OIL FILTER WRENCH (FOR TRUCK)**

- The tool is used for remove and install truck oil filter.
The serrate design makes it set in place.
- Use with Dr.1/2" or 21 mm wrench.
- Size: range 80-110 mm.



ITEM CODE	DESCRIPTION	QTY/CTN	PRICE
MK-AUT-10249	Two Way Oil Filter Wrench	24	266.30

ITEM CODE	DESCRIPTION	QTY/CTN	PRICE
MK-AUT-10250	Two Way Oil Filter Wrench (For Truck)	24	377.30

MOTORCYCLE REPAIR TOOLS



Screw Extractor Safety Uses

- Screw extractor is designed to remove broken studs, bolts, socket screws and fittings and aggressive left hand spiral design for extra gripping power
- Spiral flutes are designed to embed themselves deeper into the metal as you turn the tool, so as the fastener resistance increases, the extractor's grip increases
- Extractor size and recommended drill bit size are etched on each tool.
- Never modify the screw extractors
- Do not use a hammer to increase pressure

How to use motorcycle chain cutter correctly:

Select the right size and length chain for the bike before start

Step 1: Put the bike in neutral.

Step 2: Loosen the axle nut *this is important! *, and the lock nuts on the tension adjusters.

Step 3: Turn the tension adjusters to loosen the chain all the way, so that you can easily pull the chain off the rear sprocket.

Step 4: Using the chain cutter to remove the rivet from the chain.

Note: DO NOT cutting the chain with bolt cutters and/or a cutting wheel.

Step 5: Attach the new chain to one end of the old one with the new but don't clip/rivet it on, just put the pins through.

Now, with the bike in neutral, use the old chain to pull the new one into place on the front sprocket.

Step 6: Wrap the new chain around the rear sprocket, bring the two ends together and connect them with your new master link.

For a rivet type: Use the flaring attachment of the tool to well flare out the ends of the rivet pins, but be careful to not over tighten the link



MK-MTR-10149
7" AIR PRESURE GAUGE*

 (DIY GRADE)



ITEM CODE	DESCRIPTION	QTY/CTN	PRICE
MK-MTR-10149	7" Air Pressure Gauge	250	14.00

MK-MTR-10151
MOTORCYCLE AIR CHUCK (CHROME)*



ITEM CODE	DESCRIPTION	QTY/CTN	PRICE
MK-MTR-10151	Motorcycle Air Chuck (Chrome)	240	24.70

MK-MTR-10153A
420-428 MOTORCYCLE
CHAIN CUTTER (PIN)*



ITEM CODE	DESCRIPTION	QTY/CTN	PRICE
MK-MTR-10153A	420-428 Motorcycle Chain Cutter (Pin)	150	14.60

MK-MTR-10153B
530 MOTORCYCLE
CHAIN CUTTER (PIN)*



ITEM CODE	DESCRIPTION	QTY/CTN	PRICE
MK-MTR-10153B	530 Mr.Mark Motorcycle Chain Cutter (Pin)	120	24.50

MK-MTR-10154
420-428
MOTORCYCLE
CHAIN CUTTER*



ITEM CODE	DESCRIPTION	QTY/CTN	PRICE
MK-MTR-10154	420-428 Motorcycle Chain Cutter	300	19.80

MK-MTR-10155
EX5 CLUTCH NUT SOCKET (BIG)*



ITEM CODE	DESCRIPTION	QTY/CTN	PRICE
MK-MTR-10155	EX5 Clutch Nut Socket (Big)	340	19.80

MK-MTR-10156
EX5 CLUTCH NUT SOCKET (SMALL)*



ITEM CODE	DESCRIPTION	QTY/CTN	PRICE
MK-MTR-10156	EX5 Clutch Nut Socket (Small)	400	17.90

MK-MTR-10157
MOTORCYCLE SCRAPER
KNIFE*



ITEM CODE	DESCRIPTION	QTY/CTN	PRICE
MK-MTR-10157	Motorcycle Scraper Knife	144	30.80



MK-MTR-10161 5PCS SCREW EXTRACTOR SET*



ITEM CODE	DESCRIPTION	QTY/CTN	PRICE
MK-MTR-10161	5pcs Screw Extractor Set	150	25.00

MK-MTR-10164 RC CLUTCH PLATE OPENER*



ITEM CODE	DESCRIPTION	QTY/CTN	PRICE
MK-MTR-10164	RC Clutch Plate Opener	60	35.20

MK-MTR-10166 KRISS MAGNET PULLER SET*



ITEM CODE	DESCRIPTION	QTY/CTN	PRICE
MK-MTR-10166	Kriss Magnet Puller Set	60	42.70

MK-MTR-10168 Y125 MAGNET PULLER SET*



ITEM CODE	DESCRIPTION	QTY/CTN	PRICE
MK-MTR-10168	Y125 Magnet Puller Set	30	59.50

MK-MTR-10171 DISC BRAKE LOCK*



ITEM CODE	DESCRIPTION	QTY/CTN	PRICE
MK-MTR-10171	Disc Brake Lock	30	96.00

MK-MTR-10177 T-TYPE SCREWDRIVER*



Full length: 300mm
Size H (mm) : PH2

ITEM CODE	DESCRIPTION	QTY/CTN	PRICE
MK-MTR-10177	T-Type Screwdriver	120	15.40

MK-MTR-1193M SPECIAL HEX TOOL (MOTOR)*



ITEM CODE	SIZE	L (MM)	QTY/CTN	PRICE
MK-MTR-1193M-0810	8X10mm	250	100	20.40
MK-MTR-1193M-1012	10X12mm	250	100	20.40
MK-MTR-1193M-1113	11X13mm	250	100	20.40
MK-MTR-1193M-1214	12X14mm	250	100	20.40

MK-MTR-1192M AXLE WRENCH (MOTORCYCLE)*



ITEM CODE	SIZE	L (MM)	QTY/CTN	PRICE
MK-MTR-1192M-0809	8X9mm	250	100	20.90
MK-MTR-1192M-0810	8X10mm	250	100	20.90
MK-MTR-1192M-1012	10X12mm	250	100	20.90
MK-MTR-1192M-1214	12X14mm	250	100	20.90
MK-MTR-1192M-1417	14X17mm	250	100	20.90
MK-MTR-1192M-1422	14X22mm	250	100	20.90
MK-MTR-1192M-1719	17X19mm	250	100	20.90
MK-MTR-1192M-1722	17X22mm	250	100	20.90
MK-MTR-1192M-1723	17X23mm	250	100	20.90
MK-MTR-1192M-1724	17X24mm	250	100	20.90
MK-MTR-1192M-1923	19X23mm	250	100	20.90
MK-MTR-1192M-1924	19X24mm	250	100	20.90
MK-MTR-1192M-2227	22X27mm	250	100	20.90

MK-TOL-11192M 8PCS AXLE WRENCH SET*

CONTAINS:
8X9, 10X12, 14X17, 14X22, 17X19,
17X23, 19X23, 22X27



ITEM CODE	DESCRIPTION	QTY/CTN	PRICE
MK-TOL-11192M	8Pcs Axle Wrench Set	10	125.40

CONSTRUCTION MAINTENANCE TOOLS



Trowels Safety Uses

- Wear appropriate Personal Protective Equipment (PPE) as illustrated before using the trowel.
- Always operate in a clear work area free from hazards. Be aware of pipes, conduits and other obstacles protruding from concrete surface.
- Ensure that you have secure footing & clear access & egress to the work area while on the job.
- Ensure the work environments is well lit with all aspects of the job easily seen and discernable.
- Ensure that the blade and other guards are fitted & functional-check before starting the trowel.
- Keep all body parts such as fingers/hands, and feet well clear of blade while operating.
- Ensure blades are in flat position for initial passes to flatten out minor variations and bring up moisture.

LEVEL & MEASURING TOOLS

Measuring Tape

Do not let the measuring blade retract on its own. The spring's tension is strong enough to literally snap the tip off the blade's end.

Never slow down the blade with the same hand holding the tape measure. Over time, the edges of the blade can get sharp, which increases the possibility of slicing a finger. Also, depending on the spring's tension, if the blade retracts too fast, the tip could pinch or take a chunk of skin from your index finger.

Always hold the tape in one hand and use the thumb of opposite hand to apply pressure onto the center of the blade as it retracts.

To clean the blade, pull it out only to the point where you see dirt or water. From this point use a rag to clean both the top and bottom of the blade as it retracts. If water is involved, always wipe the blade as many times as it takes to remove any moisture left on the blade.



MK-CON-9000 CEMENT TROWEL (S/STEEL)



- 0.7mm Stainless Steel Blade.
- Strong lightweight tang and blade riveting.
- minimum of 5 rivets for strong blade attachment.
- 11" blade for laying on and finishing.

ITEM CODE	Size	QTY/CTN	PRICE
MK-CON-9000-4	4" X 11" X 0.7mm	60	19.00

MK-CON-9001 (BLUE) CEMENT TROWEL (FLEXIBLE TYPE)



- Hardened and spring tempered steel for optimal shape retention.
- Tension rolled for longitudinal rigidity, ensures consistent application.
- Flexible type. Ideal for ceiling plastering.

ITEM CODE	Size	QTY/CTN	PRICE
MK-CON-9001B-4.00	4" X 11" X 0.35mm	60	19.70

MK-CON-9002 CEMENT TROWEL (BLUE)



- Protective rust inhibiting lacquer for maximum shelf life.
- Every blade hand set by a craftman to produce the perfect 'dishing' to avoid corners digging into plaster.
- Superior cross ground blade for drag reduction and easy material flow.

ITEM CODE	Size	QTY/CTN	PRICE
MK-CON-9002-4.50	4.5" X 11" X 0.8mm	60	20.90

MK-CON-9004 CEMENT TROWEL (SPONGE FLOAT)



- A float with film rubber strongly bonded to an steel base plate for long life.

ITEM CODE	Size	QTY/CTN	PRICE
MK-CON-9004-3.00	3" X 9" X Sponge	60	13.60

MK-CON-9005 BUCKET TROWEL



- Wooden Handle, Protective lacquer
- Stonge Steel Ferule, Tang strongly weeded to blade
- Carbon Steel blade For good performance

ITEM CODE	Size	QTY/CTN	PRICE
MK-CON-9005-2.50	2 1/2" X 6"	60	10.50

MK-CON-9006 BRICKLAYING TROWEL (GERMANY STYLE)



- Manufactured from high carbon tempered and hardened steel with a group and polished finish. Tapered to remain rigid on the tip. Polished and varnished high angle handles for greater balance, control and knuckle clearance, with chromed ferrule, holds the forged steel tang in place preventing the blade from twisting.

ITEM CODE	Size	Length	QTY/CTN	PRICE
MK-CON-9006-7	7"	175mm	48	24.20
MK-CON-9006-8	8"	200mm	48	27.30



MK-CON-9009 BUILDERS LEVELS*



- Extruded aluminium body.
- Powder coated finish.
- Resilient synthetic caps protect the end of the body from knocks
- Accuracy : 0.75mm per metre when used upside down.

ITEM CODE	Size	QTY/CTN	PRICE
MK-CON-9009-18	18"		27.90
MK-CON-9009-24	24"		35.00
MK-CON-9009-36	36"		47.90
MK-CON-9009-48	48"		62.30

MK-CON-9021 BUILDERS LEVEL WITH HANDHOLE*



- Double milled surface
- Heavy duty material
- Three vial: 180, 90 and 90
- With hanging hole
- Accuracy: 0.5mm/m
- Thickness: 1.6mm

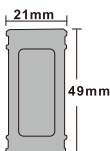

ITEM CODE	Length	L(cm)	W(cm)	H(cm)	GW/NW	QTY/CTN	PRICE
MK-CON-9021	600MM	61	32	19.5	18.5/17.5	30	68.10

MK-CON-9022 STANDARD BUILDERS LEVEL



- Bottom milled
- Three vials: 180, 90 and 45
- With one hanging hole
- Accuracy: 1.0mm/m
- Thickness: 1.3mm

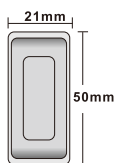

ITEM CODE	Length	L(cm)	W(cm)	H(cm)	GW/NW	QTY/CTN	PRICE
MK-CON-9022-12	300MM	31	21	16.5	6.5/5.5	30	28.40
MK-CON-9022-18	450MM	51	21	16.5	9/8	30	35.00
MK-CON-9022-24	600MM	61	21	16.5	11.50/10.50	30	41.70
MK-CON-9022-36	900MM	101	21	16.5	17/16	30	52.60

MK-CON-9023 MULTI-BEAM LASER LEVEL KIT*



MK-CON-9023



Rotary base



Tripod



Cross Laser Level

SPECIFICATION:

Working range	Line 6 meters, Dot 30 meters
Recommended Use	Indoors
Safety/Quality Approve	CE
Laser Safety Class	Class 2
Rated laser power	<1mw
Laser wave length	$\lambda=650\text{nm}$
Protection Class	III
Power supply	2-AAA Batteries 3V DC (Non-provided)
Accuracy of vials on level	$\pm 0.5\text{mm/m}$
Laser level accuracy Dot	$\pm 0.5\text{mm/m}$
Laser level accuracy	Line 0.15°/m/Cross 0.15°/m
Standard Accessory	400mm Line & Cross Laser Level, 120cm Tripod, Aluminum Rotary Base, 2 pcs AAA Battery (not include)

- Multi-purpose laser level kit.
- Can be used as normal spirit level and used as laser level.
- Laser level can be projected laser dot, horizontal line, vertical line and cross line.
- Uses in the fields of construction, engineering and indoor decoration.

ITEM CODE	Length	L(cm)	W(cm)	H(cm)	GW/NW	QTY/CTN	PRICE
MK-CON-9023	16 inch	51	46.5	30	15.50/13.50	4	310.50

MK-CON-9025 DIGITAL LEVEL*



Applied in any angle measurement.

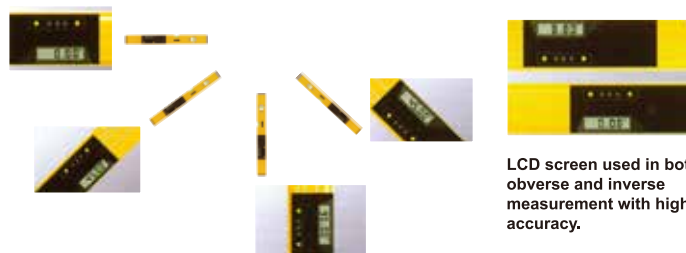

LCD screen used in both obverse and inverse measurement with high accuracy.

- Digital Aluminium Level
- 600mm length level, double milled surface
- Display any angle degree
- LCD display
- Accuracy of inclinometr: $\pm 0.3^\circ$
- GS/EMC approved
- With two vials: 180, 90
- Without laser

ITEM CODE	Length	L(cm)	W(cm)	H(cm)	GW/NW	QTY/CTN	PRICE
MK-CON-9025	600MM	60	6	2.4	6.5/6.2±0.2	4	373.60



MK-CON-9024 SELF LEVELLING LASER LEVEL*



MK-9024



1. Fixing windows

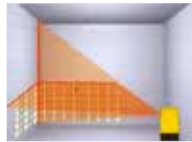

2. Put pictures on wall

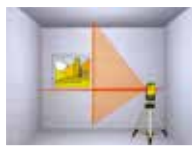

3. Tiling



Dialis used for adjusting angles



BMC



Self-Adjusting Laser



120cm Tripod

SPECIFICATION:

Working range	up to 10m
Recommended Use	Indoors
Safety/Quality Approve	CE
Laser Safety Class	Class 2
Rated laser power	<1mw
Laser wave length	$\lambda=650nm$
Protection Class	III
Power supply	3-AA Batteries 3V DC (Non-provided)
Accuracy of vials on level	$\pm 0.5mm/m$
Laser level accuracy	Line $0.15^{\circ}/m$ /Cross $0.15^{\circ}/m$
Self-Levelling range	6°
Standard Accessory	Self-Adjusting Laser, 120cm Tripod, 3pcs AA Battery (Not included)

- Recommended working range up to 32' (10m), dependent on illumination of work area, ideal working distance 3m-5m.
- Self-levelling in 6 degree.
- Includes plastic base with tripod mount with 5/8" x 11 mounting thread, quality tripod (40cm-120cm).
- The self-adjusting laser can be used either with the tripod or independently.
- Horizontal & Vertical line projection unit can be manually rotated to the full 360-degree range.

ITEM CODE	L(cm)	W(cm)	H(cm)	GW/NW	QTY/CTN	PRICE
MK-CON-9024	51	45.5	30	16/14	4	556.90

MK-CON-9026 TORPEDO LEVEL



- Plastic body with Aluminium frame
- V-groove working edge for pipe work
- Level with fixed strong magnetic
- Three vials: 45, 180 and 90

ITEM CODE	Length	L(cm)	W(cm)	H(cm)	GW/NW	QTY/CTN	PRICE
MK-CON-9026	9 inch	34	24	21.5	9.5/8.5	30	10.20

MK-CON-9027 BUILDERS LEVEL*



- Multi function aluminium level.
- With metric or inch or both metric and inch scale.
- Two high precision vials: 180, 90.
- Accuracy: 1-5 mm/m.
- With two line marker for alignment.
- 20 pins in plastic box.
- Six certain size holes for drilling work.
- With one hanging hole.

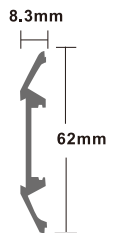

ITEM CODE	Length	L(cm)	W(cm)	H(cm)	GW/NW	QTY/CTN	PRICE
MK-CON-9027-0600	600MM	61.5	25	21.5	10.5/9.5	30	31.20
MK-CON-9027-0750	750MM	76.5	25	21.5	13/12	30	38.20
MK-CON-9027-1000	1000MM	101.5	25	21.5	17/16	30	50.20

MK-CON-9028 MEASURING TAPE (ABS Case)



- Accurate
- Professional Grade
- Heavy-duty Nylon coating extends blade life up to ten times longer
- Extra-thick blade for the longest stand-out - up to 8 feet
- Top forward blade lock design makes it easier to lock and unlock the blade
- Massive new bumper design for increased hook life

ITEM CODE	SIZE	QTY/CTN	PRICE
MK-CON-9028A	3.5m X 16mm/5/8" (12FT)	144	8.20
MK-CON-9028B	5m X 25mm/1" (16FT)	72	15.00
MK-CON-9028C	7.5m X 25mm/1" (25FT)	48	21.20



MK-CON-9029 FIBERGLASS TAPE*



- Crystal clear graduations on an easy clean surface
- Metric English blade printed both sides
- Bi-material handle and shaped winder for ease of use
- Class III Accuracy
- High impact, high visibility yellow ABS case

ITEM CODE	SIZE	QTY/CTN	PRICE
MK-CON-9029	30M X 13MM/1/1/2" (100FT)	10	96.20

MK-CON-9030 FIBERGLASS TAPE*



- Crystal clear graduations on an easy clean surface
- Metric English blade printed both sides
- Bi-material handle and shaped winder for ease of use
- Class III Accuracy
- High impact, high visibility yellow ABS case

ITEM CODE	SIZE	QTY/CTN	PRICE
MK-CON-9030	30M X 13MM/1/1/2" (100FT)	20	104.90

MK-CON-9031 CHALK LINE REEL SET*



- Traccialinee work 30m
- Powder Blue 180gm
- Universal hook designed to endure the rigors of everyday use
- Shatter resistant polypropylene case
- Freewheeling crank mechanism

ITEM CODE	SIZE	QTY/CTN	PRICE
MK-CON-9031	30MM (100FT)	20	32.00

MK-CON-9032 CHALK POWDER*



- Powder Blue 180gm

ITEM CODE	SIZE	QTY/CTN	PRICE
MK-CON-9032	180gm	40	5.90

MK-CON-9033 MK-CON-9033 SWEDISH SUPER HIGH SPEED STEEL BI-METAL H/HACKSAW BLADE*



12" X 18TPI



12" X 24TPI

ITEM CODE	SIZE	QTY/CTN	PRICE
MK-CON-9033-18T	18t 12"X18TPI HSS BI-Metal H/Hacksaw Blade	1000	5.10
MK-CON-9033-24T	24t 12"X18TPI HSS BI-Metal H/Hacksaw Blade	1000	5.10

MK-CON-9034 MK-CON-9034 SWEDISH SUPER HIGH SPEED STEEL FLEXIBLE H/HACKSAW BLADE*



12" X 18TPI



12" X 24TPI

ITEM CODE	SIZE	QTY/CTN	PRICE
MK-CON-9034-18T	18t 12"X18TPI HSS Flexible H/Hacksaw Blade	1000	5.10
MK-CON-9034-24T	24t 12"X18TPI HSS Flexible H/Hacksaw Blade	1000	5.10



MK-CON-9035 SPEED CUT HAND SAW



- Taper file teeth
- Plastic handle

ITEM CODE	SIZE	QTY/CTN	PRICE
MK-CON-9035-18	18" Hand Saw	96	32.20
MK-CON-9035-20	20" Hand Saw	96	32.20
MK-CON-9035-22	22" Hand Saw	48	35.50
MK-CON-9035-24	24" Hand Saw	48	40.50

MK-CON-9016 FLARING BENDER



- Chrome swivel, made of alloy steel reduces friction
- Designed for double or single flare in copper, aluminium, soft steel brake line and brass tubing
- For 3/16", 1/4", 5/16", 3/8", 7/16", 1/2" and 5/8" O.D tubing

ITEM CODE	DESCRIPTION	QTY/CTN	PRICE
MK-CON-9016	Flaring Bender	20	124.80

MK-CON-9018 180° 3-IN-1 TUBE TOOL



- Solid cast aluminium with machined and painted surfaces
- Marked degrees gauge accurate angles to 180° degrees
- Perfect, easy and precise bends in aluminum, copper and steel tubing without collapsing the tubing
- Ideal for air conditioning and refrigerating contracting
- For 1/4", 5/16", 3/8" O.D tubing

ITEM CODE	DESCRIPTION	QTY/CTN	PRICE
MK-CON-9018	180° 3-in-1 Tube Tool	24	81.30

MK-TOL-1551 TUBE CUTTER



- Aluminium alloy body, chrome plated finish with a spare cutting blade
- Can be used to cut tube with little effort
- Capacity: 1/8" ~ 1 1/8" O.D. tubing
- Grooved rollers for cutting new flares
- Ideal for plumbing job and home improvement application

ITEM CODE	DESCRIPTION	QTY/CTN	PRICE
MK-TOL-1551	Tube Cutter	72	80.60

MK-CON-9015 DOUBLE FLARING AND CUTTING TOOL KIT



- Chrome swivel, made of alloy steel reduces friction
- Designed for double or single flare in copper, aluminium, soft steel brake line and brass tubing
- For 3/16", 1/4", 5/16", 3/8", 7/16", 1/2" and 5/8" O.D tubing
- Supplied with MK-TOL-1551 tube cutter and flaring tool

ITEM CODE	DESCRIPTION	QTY/CTN	PRICE
MK-CON-9015	Flaring Bender	60	200.10

MK-CON-9017 90° 3-IN-1 TUBE TOOL



- Solid cast aluminium with machined and painted surfaces
- Marked degrees gauge accurate angles to 90° degrees
- Perfect, easy and precise bends in aluminum, copper and steel tubing without collapsing the tubing
- Ideal for air conditioning and refrigerating contracting
- For 1/4", 5/16", 3/8" O.D tubing

ITEM CODE	DESCRIPTION	QTY/CTN	PRICE
MK-CON-9017	90° 3-in-1 Tube Tool	36	68.90

MK-TOL-1549A TUBE CUTTER



- Aluminium alloy body, chrome plated finish with a spare cutting blade
- Can be used to cut tube with little effort
- Capacity: 1/4" ~ 1 5/8" O.D. tubing
- Grooved rollers for cutting new flares
- Ideal for plumbing job and home improvement application

ITEM CODE	DESCRIPTION	QTY/CTN	PRICE
MK-TOL-1549A	Tube Cutter	36	107.30



MK-TOL-1550 PLASTIC PIPE & EXTRUSION CUTTER



- Die-cast aluminium alloy body with proper heat treated stainless steel blade honed and shaped for smooth cutting action
- Ratchet cutting action avoids crushing pipe
- Long life blade suitable for cutting extrusions and pipes
- Ideal to cut water pipe, aluminium plastics pipe, gas pipe, electrical appliance pipe and other plastic pipeline
- Cutting range:
Normal pipe; VP 30
Water course pipe; VW 30
Electrical appliances pipe; VP 36
- Scope of cut: 36mm

ITEM CODE	DESCRIPTION	QTY/CTN	PRICE
MK-TOL-1550	Plastic Pipe & Extrusion Cutter	36	195.60

MK-TOL-1553 CUTTING BLADE



- SUJ2 material
- Capacity: 1/8" ~ 7/8" O.D. tubing

Item Code	Item	Capacity	Qty/Ctn	Price
MK-TOL-1553-049	For MK1549	1/4" ~ 1-5/8" O.D. tubing	240	11.80
MK-TOL-1553-051	For MK1551	1/8" ~ 1-1/8" O.D. tubing	240	11.80
MK-TOL-1553-052	For MK1552	1/8" ~ 7/8" O.D. tubing	240	11.80

MK-TOL-1556 120W PROFESSIONAL GLUE GUN

2 Min. Heat Time



- Features with Non-drip nozzle
- Trigger action improved gripping control
- Insulated nozzle protects against burns
- On/ Off lighted switch
- Ideal for wood, glass and metals, the high temp glue gun melts glue at higher temperatures for stronger bonds.

ITEM CODE	DESCRIPTION	QTY/CTN	PRICE
MK-TOL-1556	120W Professional Glue Gun	12	320.20

MK-TOL-1552 MINI TUBE CUTTER



- Enable to reach pipes and tubing that standard sized cutters can't
- Ideal for tight spots under sinks and behind appliances, this mini tubing cutter cuts copper, brass and aluminum tubing with ease
- Supplied with a retractable deburring blade and an extra cutter stored inside the knob of the tool
- Capacity: 1/8" ~ 7/8" O.D. tubing

ITEM CODE	DESCRIPTION	QTY/CTN	PRICE
MK-TOL-1552	MIni Tube Cutter	120	29.00

MK-TOL-1555 60W REGULAR GLUE GUN



- Features with Non-drip nozzle
- Trigger action improved gripping control
- Insulated nozzle protects against burns
- Compact size makes storage easy.
- Built-in stand keeps the hot gun off flat surfaces
- Ideal for gluing wood, glass and metals

ITEM CODE	DESCRIPTION	QTY/CTN	PRICE
MK-TOL-1555	60W Regular Glue Gun	24	59.60

MK-TOL-1557 300W INDUSTRIAL GLUE GUN

2 Min. Heat Time



- Features with Non-drip nozzle
- Trigger action improved gripping control
- Insulated nozzle protects against burns
- On/ Off lighted switch
- Supplied with a carrying case
- Ideal for various heavy duty projects, the high temp glue gun melts glue at higher temperatures for stronger bonds.
- with external adjustable temperature

ITEM CODE	DESCRIPTION	QTY/CTN	PRICE
MK-TOL-1557	300W Industrial Glue Gun	6	928.50

FOOT PROTECTION





SAFETY SHOES UNIQUENESS

MR. MARK Safety Shoes are professionally manufactured in compliance with European standards EN ISO 20345 : 2004 for quality & durability, **MR. MARK Safety Shoes** are using the most advanced GERMAN DESMA direct injection machinery combined with openness, innovation and the desire for change.



Description of Protection

- Steel Toe Cap to withstand and impact load of 200 Joules and compression of 15000N
- Penetration Resistance of 1100N
- Electrical Resistance - Antistatic, minimum 100 K, Maximum 1000 M
- Oil Resistance
- Energy Absorption of Seat Region 20 joules
- Slip Resistance

MK-SSS-280N

RANGER

GENUINE GRAIN LEATHER



- Rot proof non-woven lining throughout.
- Fully lined and anti-dust tongue.
- Padded tongue for comfort wearing.
- Deluxe padded collar for extra confort.
- High quality webbing fastening.
- Shaped steel mid-sole to provide added protection from sharp objects below (optional)
- Corrosion resistant eyelets.
- Stiffener strengthen and supports back part of shoe.
- Steel toe cap with strength of 200J & 15000N
- Anti-slip flexible PU sole, resistance to oil and most chemicals.

ITEM CODE	DESCRIPTION	QTY/CTN	PRICE
MK-SSS-280N-03	Ranger Genuine Grain Leather	10	158.00
MK-SSS-280N-04	Ranger Genuine Grain Leather	10	158.00
MK-SSS-280N-05	Ranger Genuine Grain Leather	10	158.00
MK-SSS-280N-06	Ranger Genuine Grain Leather	10	158.00
MK-SSS-280N-07	Ranger Genuine Grain Leather	10	158.00
MK-SSS-280N-08	Ranger Genuine Grain Leather	10	158.00
MK-SSS-280N-09	Ranger Genuine Grain Leather	10	158.00
MK-SSS-280N-10	Ranger Genuine Grain Leather	10	158.00
MK-SSS-280N-11	Ranger Genuine Grain Leather	10	158.00
MK-SSS-280N-12	Ranger Genuine Grain Leather	10	158.00
MK-SSS-280N-13	Ranger Genuine Grain Leather	10	158.00

MK-SSS-281N

LEGEND

GENUINE GRAIN LEATHER



- Rot proof non-woven lining throughout.
- Fully lined and anti-dust tongue.
- Padded tongue for comfort wearing.
- Deluxe padded collar for extra confort.
- High quality webbing fastening.
- Shaped steel mid-sole to provide added protection from sharp objects below (optional)
- Corrosion resistant eyelets.
- Stiffener strengthen and supports back part of shoe.
- Steel toe cap with strength of 200J & 15000N
- Anti-slip flexible PU sole, resistance to oil and most chemicals.

ITEM CODE	DESCRIPTION	QTY/CTN	PRICE
MK-SSS-281N-05	Legend Genuine Grain Leather	10	190.00
MK-SSS-281N-06	Legend Genuine Grain Leather	10	190.00
MK-SSS-281N-07	Legend Genuine Grain Leather	10	190.00
MK-SSS-281N-08	Legend Genuine Grain Leather	10	190.00
MK-SSS-281N-09	Legend Genuine Grain Leather	10	190.00
MK-SSS-281N-10	Legend Genuine Grain Leather	10	190.00
MK-SSS-281N-11	Legend Genuine Grain Leather	10	190.00



MK-SSS-284N PROTECTOR GENUINE GRAIN LEATHER



- Rot proof non-woven lining throughout.
- Fully lined and anti-dust tongue.
- Padded tongue for comfort wearing.
- Deluxe padded collar for extra confort.
- High quality webbing fastening.
- Shaped steel mid-sole to provide added protection from sharp objects below (optional)
- Corrosion resistant eyelets.
- Stiffener strengthen and supports back part of shoe.
- Steel toe cap with strength of 200J & 15000N
- Anti-slip flexible PU sole, resistance to oil and most chemicals.

ITEM CODE	DESCRIPTION	QTY/CTN	PRICE
MK-SSS-284N-05	Protector Genuine Grain Leather	10	188.00
MK-SSS-284N-06	Protector Genuine Grain Leather	10	188.00
MK-SSS-284N-07	Protector Genuine Grain Leather	10	188.00
MK-SSS-284N-08	Protector Genuine Grain Leather	10	188.00
MK-SSS-284N-09	Protector Genuine Grain Leather	10	188.00
MK-SSS-284N-10	Protector Genuine Grain Leather	10	188.00
MK-SSS-284N-11	Protector Genuine Grain Leather	10	188.00

MK-SSS-289N TEXAN GENUINE GRAIN LEATHER



- Rot proof non-woven lining throughout.
- Fully lined and anti-dust tongue.
- Padded tongue for comfort wearing.
- Deluxe padded collar for extra confort.
- High quality webbing fastening.
- Shaped steel mid-sole to provide added protection from sharp objects below (optional)
- Corrosion resistant eyelets.
- Stiffener strengthen and supports back part of shoe.
- Steel toe cap with strength of 200J & 15000N
- Anti-slip flexible PU sole, resistance to oil and most chemicals.)

ITEM CODE	DESCRIPTION	QTY/CTN	PRICE
MK-SSS-289N-05	Texan Genuine Grain Leather	5	255.00
MK-SSS-289N-06	Texan Genuine Grain Leather	5	255.00
MK-SSS-289N-07	Texan Genuine Grain Leather	5	255.00
MK-SSS-289N-08	Texan Genuine Grain Leather	5	255.00
MK-SSS-289N-09	Texan Genuine Grain Leather	5	255.00
MK-SSS-289N-10	Texan Genuine Grain Leather	5	255.00
MK-SSS-289N-11	Texan Genuine Grain Leather	5	255.00

MK-SS 8870 AIR WALK safety pvc shoes

- High quality soft urethane PVC Upper.
- Safety toe cap manufactured to meet DIN32768 standard
- Oil & Chemical resistant sole.
- Shaped steel mid-sole to provide added protection from sharp objects below (optional)
- Anti-slip heel.
- Chemical resistant sole.
- Non-absorbant polyester lining makes thorough cleaning easy.
- Non-hazardous liquid protection.
- Available in men's size 5-11
- Extra wide fitting.
- Available in Yellow / Black
- Meets : MS 967-1985



ITEM CODE	DESCRIPTION	QTY/CTN	PRICE
MK-SS 8870-05	Air Walk Safety PVC Shoes	10	88.00
MK-SS 8870-06	Air Walk Safety PVC Shoes	10	88.00
MK-SS 8870-07	Air Walk Safety PVC Shoes	10	88.00
MK-SS 8870-08	Air Walk Safety PVC Shoes	10	88.00
MK-SS 8870-09	Air Walk Safety PVC Shoes	10	88.00
MK-SS 8870-10	Air Walk Safety PVC Shoes	10	88.00

MK-SS 8880 AIR WALK pvc rain shoes

- Use for sure-footing in muddy conditions.
- These black boots and work shoes should be mandatory equipment for construction workers and general-maintenance personnel.
- Designed for light-duty.
- Shaped steel mid-sole to provide added protection from sharp objects below (optional)
- Non-hazardous liquid protection
- These boots and shoes have cleated soles.
- Polyester lining is easy to clean.
- Made from recycled materials.
- 15" high kee boots are a favorite among construction concrete and utility workers.
- Available in men's size 5-11



ITEM CODE	DESCRIPTION	QTY/CTN	PRICE
MK-SS 8880-05	Act Walk PVC Rain Shoes	10	33.00
MK-SS 8880-06	Act Walk PVC Rain Shoes	10	33.00
MK-SS 8880-07	Act Walk PVC Rain Shoes	10	33.00
MK-SS 8880-08	Act Walk PVC Rain Shoes	10	33.00
MK-SS 8880-09	Act Walk PVC Rain Shoes	10	33.00
MK-SS 8880-10	Act Walk PVC Rain Shoes	10	33.00
MK-SS 8880-11	Act Walk PVC Rain Shoes	10	33.00



MK-SS 8890

FREE WALK pvc rain shoes

- Use for sure-footing in muddy conditions.
- These yellow boots and work shoes should be mandatory equipment for construction workers and general-maintenance personnel.
- Designed for light-duty.
- Shaped steel mid-sole to provide added protection from sharp objects below (optional)
- Non-hazardous liquid protection
- These boots and shoes have cleated soles.
- Polyester lining is easy to clean.
- Made from recycled materials.
- 15" high kee boots are a favorite among construction concrete and utility workers.
- Available in men's size 5-11



ITEM CODE	DESCRIPTION	QTY/CTN	PRICE
MK-SS 8890-05	Free Walk PVC Rain Shoes	10	35.20
MK-SS 8890-06	Free Walk PVC Rain Shoes	10	35.20
MK-SS 8890-07	Free Walk PVC Rain Shoes	10	35.20
MK-SS 8890-08	Free Walk PVC Rain Shoes	10	35.20
MK-SS 8890-09	Free Walk PVC Rain Shoes	10	35.20
MK-SS 8890-10	Free Walk PVC Rain Shoes	10	35.20
MK-SS 8890-11	Free Walk PVC Rain Shoes	10	35.20

MK-SS 9000

ACTION WALK pvc rain shoes

- Use for sure-footing in muddy conditions.
- These black boots and work shoes should be mandatory equipment for construction workers and general-maintenance personnel.
- Designed for light-duty.
- Non-hazardous liquid protection
- Hardwearing, strong, abrasive resistant sole
- Lightweight PVC.
- Non-slip sole and fully washable lining.



ITEM CODE	DESCRIPTION	QTY/CTN	PRICE
MK-SS 9000-05	Action Walk PVC Rain Shoes	50	15.60
MK-SS 9000-06	Action Walk PVC Rain Shoes	50	15.60
MK-SS 9000-07	Action Walk PVC Rain Shoes	50	15.60
MK-SS 9000-08	Action Walk PVC Rain Shoes	50	15.60
MK-SS 9000-09	Action Walk PVC Rain Shoes	50	15.60
MK-SS 9000-10	Action Walk PVC Rain Shoes	50	15.60



EYE PROTECTION



MK-SSE-901 WELDING GOGGLE



- Ultra-light anallergic frame
- Elastic headband
- Glass lenses, diameter 50mm
- Outer 90° flip-up lenses
- Indirect ventilation valve
- Green soft PVC frame, ABS lens holder
- Four vents in the Frame and be used in welding workplace

MODEL	FRONT	SLEEVE	TEMPLE	NOSE PAD	LENS
MK-SSE 901	BLACK	-	BLACK	GREEN	BLACK (GREEN)

ITEM CODE	DESCRIPTION	QTY/CTN	PRICE
MK-SSE-901	Welding Goggle	60	22.90

MK-SSE-903 AXIS SAFETY SPECTACLE*



- Ergonomic Wrap-around Frame for unmatched eye socket protection
- Built-in Brow Guard with ventilation design
- Soft, elastomeric nose pieces for cushioned comfort
- Unique angle adjustable temples
- Soft EVA foam affixed on the inside of temple for comfortable fit
- Standard lens features high impact resistant, scratch resistant and blocks 99.9% of harmful UV radiation

CODE NO.

MK-SSE 903A U EN175FCE
 MK-SSE 903B U EN175FCE

MODEL	FRONT	SLEEVE	TEMPLE	NOSE PAD	LENS
MK-SSE 903A	SLATE METAL	-	SLATE METAL	BLACK	SMOKE-HC
MK-SSE 903B	BLUE METAL	-	BLUE METAL	BLACK	CLEAR-HC

ITEM CODE	DESCRIPTION	QTY/CTN	PRICE
MK-SSE-903A	Axis Safety Spectacle	144	24.80
MK-SSE-903B	Axis Safety Spectacle	144	24.80

MK-SSE-902 SAFETY GOGGLE



- Protects against chemical splash and dust
- Also available as gas welding goggle IR 2, 3, 5 filter shades
- Optically correct polycarbonate lens
- Ventilative holes build in the soft vinyl goggle body
- Conforms to facial contours for a very comfortable fit
- Impact resistance against flying particles
- Fully adjustable elastic band
- Fits over most prescription glasses
- Meets ANSI Z87.1, CE EN 166
- Polycarbonate-class 1 lens
- Filters out 99.9% of all harmful UV light
- Full side and brow protection

MODEL	FRONT	SLEEVE	TEMPLE	NOSE PAD	LENS
MK-SSE 902	CLEAR	-	CLEAR	CLEAR	CLEAR

ITEM CODE	DESCRIPTION	QTY/CTN	PRICE
MK-SSE-902	Safety Goggle	200	11.40

MK-SSE-904 SILIUM SAFETY SPECTACLE*



- The fashionable design appeal to both men and women, helping to ensure worker acceptance
- Straight temples, no adjustments necessary
- High impact polycarbonate for maximum protection in accordance with EN166
- Anatomically shaped bridge to adapt to all face
- The softness of the temples ensure a pressure-free fit
- With innovative lenses and side piece

CODE NO.

MK-SSE 904A U EN175FCE

MODEL	FRONT	SLEEVE	TEMPLE	NOSE PAD	LENS
MK-SSE 904A	BLACK	-	BLACK	BLACK	SMOKE-HC

ITEM CODE	DESCRIPTION	QTY/CTN	PRICE
MK-SSE-904A	Silium Safety Spectacle	144	16.90

MK-SSE-905 VIPER SAFETY SPECTACLE



- Tight fitting 10 base lens offers unlimited wrap-around sight
- One-piece construction for optimum coverage of the eyes
- Contemporary frame design integral to lens with universal nose pad
- Contoured side shields, extended from lens, provide better protection
- Lens absorbs 99.9% harmful UV light and resists high impact
- No metal part, no screw
- Meet ANSI Z87.1-2003 and CE EN 166

CODE NO.

MK-SSE 905A U EN175FCE
 MK-SSE 905B U EN175FCE

MODEL	FRONT	SLEEVE	TEMPLE	NOSE PAD	LENS
MK-SSE 905A	-	-	SMOKE	-	SMOKE-HC
MK-SSE 905B	-	-	CLEAR	-	CLEAR-HC

ITEM CODE	DESCRIPTION	QTY/CTN	PRICE
MK-SSE-905A	Viper Safety Spectacle	144	9.60
MK-SSE-905B	Viper Safety Spectacle	144	9.60



MK-SSE-910 SQUALE SAFETY SPECTACLE



- 100% made from polycarbonate
- Universal fit
- Fits over most prescription frames
- Full front, side and top(brow) protection
- Options: non-coated, anti-scratch coated or anti-fog coated available
- Suitable as everyday use safety spectacle
- Suitable as throw away visitor spec
- Meets ANSI Z87.1, CE EN 166, AS/NZS 1337
- 2.2mm-polycarbonate-class 1 lens
- Filters out 99.9%of all harmful UV light

MODEL	FRONT	SLEEVE	TEMPLE	NOSE PAD	LENS
MK-SSE 910	-	-	CLEAR	-	CLEAR-HC

ITEM CODE	DESCRIPTION	QTY/CTN	PRICE
MK-SSE-910	Squale Safety Spectacle	144	11.00

MK-SSE-913 SPORTY SUNGLASSES SAFETY SPECTACLE



- Fashionable design resembles sunglasses, suitable for both men and women
- Close-fitting, unitary front with dual 9.5 base
- Durable dual injected polycarbonate and rubber temples
- "Finger" type, cushioned nosepiece fits a wide range of bridge sizes and protects against slippage
- Scratch-resistant, hard-coated 100% polycarbonate lenses filter out more than 99.9% of harmful UV radiation
- Meet ANSI Z87.1-2003 and CE EN166 standards

MODEL	FRONT	SLEEVE	TEMPLE	NOSE PAD	LENS
MK-SSE 913	BLUE	BLACK/BLUE	BLACK	BLUE	BLUE

ITEM CODE	DESCRIPTION	QTY/CTN	PRICE
MK-SSE-913	MCR Safety Welding Goggle	144	26.50

MK-SSE-917 MCR SAFETY WELDING GOGGLE



- Treated with our exclusive Duramass® scratch-resistant coating
- Vented to decrease fogging
- Flip and stationary lens available
- Meets or exceeds ANSI Z87.1 safety standards
- Green soft PVC frame, ABS lens holder
- Six indirect vents in the frame, and be used in welding workplace.

MODEL	FRONT	SLEEVE	TEMPLE	NOSE PAD	LENS
MK-SSE-917	BLACK/GREEN	DARK GREEN	BLACK/GREEN	-	BLACK

ITEM CODE	DESCRIPTION	QTY/CTN	PRICE
MK-SSE-917	MCR Safety Welding Goggle	144	26.50

MK-SSE-919 PATRIOT SAFETY SPECTACLE



- 9.75 base curvature offers wide and unobstructed vision
- Soft nosepiece and temple pad for cushion fit
- Incredibly light, resilient & durable protective eyewear for all day wear
- Snug-fitting wrap around lens provides perfect impact protection around the eyes
- Fashionable design resembles sunglasses, suitable for both men and women
- Scratch-resistant, hard coated 100% polycarbonate lens filter out more than 99.9% of harmful light
- Meet: ANSI Z87.1-2003 & CE EN166 standards

MODEL	FRONT	SLEEVE	TEMPLE	NOSE PAD	LENS
MK-SSE 919	BLACK	BLACK	BLACK	BLACK	SMOKE-HC

ITEM CODE	DESCRIPTION	QTY/CTN	PRICE
MK-SSE-919	Patriot Safety Spectacle	144	15.10



MK-SSE-920 PARMA SAFETY GOGGLE*



- Soft rubber frame provides comfort for long time wearing.
- Flexible housing fits most prescription eyewear (over-spec).
- Universal fit nose bridge conforms to facial contours to ensure a comfortable fit.
- Fully adjustable headband fits most users.
- Indirect venting system offers ventilation and dust prevention simultaneously.
- Anti fog, Scratch resistant polycarbonate lens filters out more than 99.9% of harmful UV radiation.
- Meet: ANSI Z87.1-2003 & CE EN166 standards.

MODEL	FRONT	SLEEVE	TEMPLE	NOSE PAD	LENS
MK-SSE 920A	BLACK	BLACK	BLACK	-	SMOKE
MK-SSE 920B	BLACK	BLACK	BLACK	-	CLEAR

ITEM CODE	DESCRIPTION	QTY/CTN	PRICE
MK-SSE-920A	Parma Safety Spectacle	100	56.00
MK-SSE-920B	Parma Safety Spectacle	100	56.00

MK-SSE-922 TOWA SAFETY SPECTACLE



- One-piece lens styling with a dual-lens look
- Built-in brow protection
- Soft nosepiece for non-slip and comfortable fit
- Wide temple design offers extra large side protection
- Lens filters out 99.9% of harmful UV light
- High impact resistant CE EN166 approval; Meet ANSI Z87.1 standard

MODEL	FRONT	SLEEVE	TEMPLE	NOSE PAD	LENS
MK-SSE 922	GREY	-	GREY	BLACK	SILVER-MIRROR

ITEM CODE	DESCRIPTION	QTY/CTN	PRICE
MK-SSE-922	Towa Safety Spectacle	144	17.10

MK-SSE-924 LED LIGHT FOR SPECTACLE*



- Size: L33.0 mm x W30.0 mm x H21.5 mm (including the clip system)
- Weight: 9 g (including 4 pcs of batteries, LR41)
- Adjustable angle: 360° (Universal-joint design)
- Suggested battery: LR41 * 4 pcs
- Battery life time: 30-60 days based on intermittent usage
6-12 hours based on continuous usage
- The LED light can be easily clipped on most of the glasses, caps, rim of helmet, bicycles for illumination, and also available for clamped on books or magazines for reading lamp.
- Patented Universal joint design, users can adjust the beam to any direction. Therefore, it is suitable for users working under dark or low light environments.
- Extremely light weight - 9.0 grams with 4 batteries included.
- The lighting can reach 200 cm the farthest; most brilliant distance 15-70 cm.

ITEM CODE	DESCRIPTION	QTY/CTN	PRICE
MK-SSE-924	LED Light for Spectacle	60	51.70

MK-SSE-925 WARRIOR SAFETY SPECTACLE*



- Safety Spectacles
- Smoke Black
- Orange Rubber Cushion
- Completely Frameless safety spectacles for unrestricted vision in all directions.
- Built-in Side Shields for added " Lateral protection"
- Soft-nose bridge for all day comfort.
- Products with Anti-slippery arm grip
- Provide impact resistant, UV filtering & sun-glare protection, suitable when working close to source of flying particles
- Single polycarbonate lens with Integral side shields & Brow bar
- Meet
- * CE EN 166 (Impact protection)
- * CE EN 170 (UV filtering protection)
- * CE EN 172 (Sun-glare protection) & ANSI Z87.1

ITEM CODE	DESCRIPTION	QTY/CTN	PRICE
MK-SSE-925	Warrior Safety Spectacle	300	13.30



MK-SSE-926 CAMOUFLAGE SAFETY SPECTACLE*



- Safety Spectacles
- Smoke Black or Gray
- Orange Rubber Cushion
- Meet
- * CE EN 166 (Impact protection)
- * CE EN 170 (UV filtering protection)
- * CE EN 172 (Sun-glare protection) & ANSI Z87.1

ITEM CODE	DESCRIPTION	QTY/CTN	PRICE
MK-SSE-926	Camouflage Safety Spectacle	300	17.20

MK-SSE-927 PHANTOM SAFETY SPECTACLE*



- Safety Spectacles
- Smoke Black
- Orange Rubber Cushion
- Super Light weight for all day comfort, all weight less than 24 grams.
- Completely frameless for unobstructed vision in all directions.
- Single polycarbonate lens.
- Meet
- * CE EN 166 (Impact protection)
- * CE EN 170 (UV filtering protection)
- * CE EN 172 (Sun-glare protection) & ANSI Z87.1

ITEM CODE	DESCRIPTION	QTY/CTN	PRICE
MK-SSE-927	Phantom Safety Spectacle	300	12.20

EAR PROTECTION





MK-SER-4001 EASY EARMUFF*



- MK-SER 4001 meet ANSI S3.19
- MK-SER 4001 CE EN 352-1 approval
- NRR value: 20dB
- SNR value: 27dB
- POM headband, ABS cup and soft PVC leather.
- Adjustable slot on each side to adjust for a snug, comfortable fit 3 position adjustable headband - head, neck or chin.
- Comfortable fit and flexible reinforced with automatic adjustment for a snug plastic headband.
- Non-toxic soft foam earcup cushion.
- Internal acoustic foam pad.

ITEM CODE	DESCRIPTION	QTY/CTN	PRICE
MK-SER-4001	Easy Earmuff	36	38.80

MK-SER-4002 ARENA FOLDING EARMUFF*



- MK-SER 4002 meet ANSI S3.19
- MK-SER 4002 CE EN 352-1 approval
- NRR value: 20dB
- SNR value: 27dB
- POM headband, HIPS cup and soft PVC leather.
- It foldable & pocket size for easily storage & carry with high function of NRR value, suitable use in high volume or noisy working environment.
- Comfortable fit and flexible reinforced with automatic adjustment for a snug plastic headband.
- Non-toxic soft foam earcup cushion.
- Internal acoustic foam pad.

ITEM CODE	DESCRIPTION	QTY/CTN	PRICE
MK-SER-4002	Arena Folding Earmuff	60	34.90

MK-SER-4003 SPARY EARMUFF WITH FOAM HEADBAND*



- MK-SER 4003 meet ANSI S3.19
- MK-SER 4003 CE EN 352-1 approval
- NRR value: 20dB
- SNR value: 27dB
- POM headband, ABS cup and soft PVC leather.
- Adjustable slot on each side to adjust for a snug, comfortable fit 3 position adjustable headband - head, neck or chin.
- Comfortable fit and flexible reinforced with automatic adjustment for a snug plastic headband.
- Non-toxic soft foam earcup cushion.
- Internal acoustic foam pad.

ITEM CODE	DESCRIPTION	QTY/CTN	PRICE
MK-SER-4003	Spary Earmuff with foam headband	36	36.00

MK-SER-4004 CRAZE EARMUFF WITH PADDED HEADBAND*



- MK-SER 4004 meet ANSI S3.19
- MK-SER 4004 CE EN 352-1 approval
- NRR value: 27dB
- SNR value: 30dB
- POM headband, HIPS cup and soft PVC leather.
- It foldable & pocket size for easily storage & carry with high function of NRR value, suitable use in high volume or noisy working environment.
- Comfortable fit and flexible reinforced with automatic adjustment for a snug plastic headband.
- Non-toxic soft foam earcup cushion.
- Internal acoustic foam pad.

ITEM CODE	DESCRIPTION	QTY/CTN	PRICE
MK-SER-4004	Craze Earmuff With Padded Headband	60	18.60



MK-SER-4005 BULLET EAR PLUG*



- The very soft polyurethane foam provides comfortable and close-fitting seal against harmful noise.
- One size fits all.
- Uncorded, pair in a polybag for economical.
- Compliance: CE EN 352-2 ANSI S3.19
- SNR value: 37dB
- NRR value: 32dB

ITEM CODE	DESCRIPTION	QTY/CTN	PRICE
MK-SER-4005	Bullet Ear Plug	500	1.70

MK-SER-4007 EAR PLUG WITH NECK STRING TRIPLE FLANGE*



- Soft and thin pliable material with triple flange design, triple seal against harmful noise, fit the ear canal perfectly.
- With neck string, plastic case and chain for convenient carrying.
- Compliance: CE EN 352-2 ANSI S3.19
- SNR value: 23dB
- NRR value: 25dB

ITEM CODE	DESCRIPTION	QTY/CTN	PRICE
MK-SER-4007	Ear Plug With Neck String Triple Flange	500	3.00

MK-SER-4008 TRIPLE FLANGE EAR PLUG*



- Soft and thin pliable material with triple flange design, triple seal against harmful noise, fit the ear canal perfectly.
- Without neck string, pair in a polybag for economical.
- Compliance: CE EN 352-2 ANSI S3.19
- SNR value: 23dB
- NRR value: 25dB

ITEM CODE	DESCRIPTION	QTY/CTN	PRICE
MK-SER-4008	Triple Flange Ear Plug	500	2.60



HEAD AND FACE PROTECTION



MK-SSH-3601 WELD COMBINATION HEAD PROTECTOR*



- Combination head protectors for head, eyes, face, hearing.
- Includes safety helmet, earmuff, faceshield holder and visor.
- Suitable for every kind of industries: Metal-cutting operation, spray painting, carpentry, house remodified and decoration petroleum industry, chemical engineering, agriculture, grinding process, electric welding, iron and steel industry etc.

MK-SSH-3602 WISHIELD CLEAR FACE SHIELD*



- Headgear with PP browguard eliminates forehead injury, complete with 8"X15-1/2" PC clear visor.
- Provides protection against foreign particles, chemical splash, dust, heat and impact resistance.
- Visor holder size: 48cm x 10cm
- Visor size: 8" x 15.5" & 8" x 12"

ITEM CODE	DESCRIPTION	QTY/CTN	PRICE
MK-SSH-3601	Weld Combination Head Protector	20	108.00

ITEM CODE	DESCRIPTION	QTY/CTN	PRICE
MK-SSH-3602	Wishield Clear Face Shield	40	58.40

MK-SSH-3603 WEDD WINE MESH FACE SHIELD*



- ABS browguard with adjustable pinlock or ratchet suspension.
- Cotton sweat band or black foam band provide greater sweat absorption.
- One piece design offering 180 degrees head protection made from durable Polyethylene.
- Quicklock clips for quick and easy visor replacement.
- One piece wraparound allowing for unobstructed views and excellent side protection.
- Visor holder size: 48cm x 10cm
- Visor size: 8" x 15.5" & 8" x 12"

MK-SSH-3605 WELDY WELDING HELMET WITH HANDLE*



- Toughness and moisture proof polypropylene straight shell.
- Outside handle.
- Lenses included.
- Unique design with fixed front 2" x 2-1/4" lens, for eyes and full face protection from sparks and spatter where litter or no hands-on work is performed.

ITEM CODE	DESCRIPTION	QTY/CTN	PRICE
MK-SSH-3603	Wedd Wine Mesh Face Shield	40	48.40

ITEM CODE	DESCRIPTION	QTY/CTN	PRICE
MK-SSH-3605	Weldy Welding Helmet With Handle	30	17.20



**MK-SSH-3606
WOB WELDING HELMET
WITH FLIP FRONT***



- Straight shell impact resistance.
- 4-1/2" x 5-1/4" window size.
- Adjustable ratchet suspension.
- Straight top cover perfectly well over the head for added protection.
- Lenses included.

ITEM CODE	DESCRIPTION	QTY/CTN	PRICE
MK-SSH-3606	WOB Welding Helmet With Flip Front	20	73.90

**MK-SSH-3607
HARDEN SAFETY HELMET***



- Compliance with CE.ANSI Z89.1
- Safety helmet with a high density poly propylene shell with vents.
- Soft comfortable 4-point polyethylene hardness with either slip or ratchet adjustment.
- Default with CS2 polyethylene hardness.

ITEM CODE	DESCRIPTION	QTY/CTN	PRICE
MK-SSH-3607	Harden Safety Helmet	50	28.90

**MK-SSH-3607
CRASHPROOF SAFETY HELMET***



- Compliance with CE.ANSI Z89.1
- Around cap brow is suitable to outdoor long time presenting from sunshine and rain.
- A completed wraparound peak
- High density polypropylene shell suitable for CS5/CS55.
- 4-point polyethylene (CS5) or webbing (CS55) hardness with either slip or ratchet adjustment.
- Default with CS2 polyethylene hardness.

ITEM CODE	DESCRIPTION	QTY/CTN	PRICE
MK-SSH-3608-YLW		20	38.50

SPECIAL HAZARD WORK WEAR





MK-SSC-20018 WARDER RAINWEAR*



- Outshell: 300D Polyester Oxford with PU Coating.
- Padding: 220G/SQM Polyester
- Lining: 190T Polyester Taffeta
- 3M Scotchlite On Body & Sleeve
- Concealed Hood
- Inner Mobile Pocket
- Inner Map Pocket
- Taped seam and waterproof
- Size: M/L/XL



ITEM CODE	DESCRIPTION	QTY/CTN	PRICE
MK-SSC-20018-M	Warder Rainwear	10	449.30
MK-SSC-20018-L	Warder Rainwear	10	449.30
MK-SSC-20018-XL	Warder Rainwear	10	449.30

MK-SSC-20029 LEATHER APRON*



- Made from Heavy duty leather.
- A small pocket to hold your valuables.
- Leather straps.



ITEM CODE	DESCRIPTION	QTY/CTN	PRICE
MK-SSC-20029	Leather Apron	25	120.00

MK-SSC-20026 SAFETY SINGLE VEST*



- With 2" width silver high visibility reflective tape horizontal bands around the torso, provides maximum visibility for safety.
- Light weight and durable, retains its color under toughest weather.
- Fluorescent yellow or fluorescent red waistcoat with adjustable hook-and-loop closure.
- Good for construction workers, street workers, public utilities, policeman, etc.
- Conforms to CE EN471 Class 2
- Color: Fluorescent Yellow
Fluorescent Red



ITEM CODE	DESCRIPTION	QTY/CTN	PRICE
MK-SSC-20026-M	Safety Single Vest	50	22.30
MK-SSC-20026-L	Safety Single Vest	50	22.30
MK-SSC-20026-XL	Safety Single Vest	50	22.30
MK-SSC-20026-XXL	Safety Single Vest	50	22.30

MK-SSC-20027 SAFETY POLOTEX VEST*



- With 2" width silver high visibility reflective tape across the chest and over shoulders, provides maximum visibility for safety.
- Light weight and durable, retains its color under toughest weather.
- Fluorescent yellow or fluorescent red waistcoat with adjustable hook-and-loop closure.
- Good for construction workers, street workers, public utilities, policeman, etc.
- Conforms to CE EN471 Class 2
- Color: Fluorescent Yellow
Fluorescent Red



ITEM CODE	DESCRIPTION	QTY/CTN	PRICE
MK-SSC-20027-L	Safety Polotex Vest	50	27.00
MK-SSC-20027-M	Safety Polotex Vest	50	28.00
MK-SSC-20027-XL	Safety Polotex Vest	50	29.00
MK-SSC-20027-XXL	Safety Polotex Vest	50	30.00

MK-SSC-20030 CANVAS APRON*



- Heavy duty canvas.
- 2 large & 2 chest level pockets.
- Cotton waist ties.



ITEM CODE	DESCRIPTION	QTY/CTN	PRICE
MK-SSC-20030	Canvas Apron	50	58.00



MK-SSC-20031 PATRIOT RAINWEAR*



(Blue)



(Red)

- ▶ Outshell: 300D polyester Oxford with pu coating
 - ▶ Lining: 190T polyester Taffeta
 - ☑ Concealed hood with velcro closure
 - ☑ Name card pocket on sleeve
 - ☑ 3D cutting on sleeve
 - ☑ Zipper underarm for breathable purpose
 - ☑ Taped seam, waterproof
 - ☑ Jacket c/w rear reflective imprint
- Colour: Blue with Black/Grey or Red with Black/Grey

ITEM CODE	DESCRIPTION	QTY/CTN	PRICE
MK-SSC-20031-B-M	Patriot Rainwear (Blue)	10	236.30
MK-SSC-20031-B-L	Patriot Rainwear (Blue)	10	236.30
MK-SSC-20031-B-XL	Patriot Rainwear (Blue)	10	236.30
MK-SSC-20031-R-M	Patriot Rainwear (Red)	10	236.30
MK-SSC-20031-R-L	Patriot Rainwear (Red)	10	236.30
MK-SSC-20031-R-XL	Patriot Rainwear (Red)	10	236.30

MK-SSC-20033 LOVELY GIRL RAINWEAR*



(Blue)



(Red)

- ▶ Outshell: Nylon with pvc coating
 - ▶ Lining: 190T polyester Taffeta
 - ▶ Detachable Hood
 - ☑ Concealed hood with velcro closure
 - ☑ Name card pocket on sleeve
 - ☑ 3D cutting on sleeve
 - ☑ Zipper underarm for breathable purpose
 - ☑ Taped seam, waterproof
 - ☑ Jacket c/w rear reflective imprint
- Colour: Blue or Red

ITEM CODE	DESCRIPTION	QTY/CTN	PRICE
MK-SSC-20033-B-M	Lovely Girl Rainwear (Blue)	10	123.20
MK-SSC-20033-B-L	Lovely Girl Rainwear (Blue)	10	123.20
MK-SSC-20033-B-XL	Lovely Girl Rainwear (Blue)	10	123.20
MK-SSC-20033-R-M	Lovely Girl Rainwear (Blue)	10	123.20
MK-SSC-20033-R-L	Lovely Girl Rainwear (Blue)	10	123.20
MK-SSC-20033-R-XL	Lovely Girl Rainwear (Blue)	10	123.20

MK-SSC-20034 SWEETY RAINWEAR*



(Blue)



(Purple)

- ▶ Outshell: Pongee with pvc coating
 - ▶ Lining: 190T polyester Taffeta
 - ☑ Concealed hood with velcro closure
 - ☑ Name card pocket on sleeve
 - ☑ 3D cutting on sleeve
 - ☑ Zipper underarm for breathable purpose
 - ☑ Taped seam, waterproof
 - ☑ Jacket c/w rear reflective imprint
- Colour: Blue /White or Purple/White

ITEM CODE	DESCRIPTION	QTY/CTN	PRICE
MK-SSC-20034-B-M	Sweety Rainwear (Blue/White)	10	126.50
MK-SSC-20034-B-L	Sweety Rainwear (Blue/White)	10	126.50
MK-SSC-20034-B-XL	Sweety Rainwear (Blue/White)	10	126.50
MK-SSC-20034-R-M	Sweety Rainwear (Purple/White)	10	126.50
MK-SSC-20034-R-L	Sweety Rainwear (Purple/White)	10	126.50
MK-SSC-20034-R-XL	Sweety Rainwear (Purple/White)	10	126.50

RESPIRATOR PROTECTION



**MK-SMS-5001
MASKI RESPIRATOR***



- Respirator is consist of black comfortable rubber fitable facepiece Gray ABS cartridge holder.
- Adjustable elastic head strap reinforcement PE headband and anti-particulate per-filter, could fit in different cartridges by respirator as below.
- Anti-dust
- Anti-organic vapors
- Anti-ammonia

ITEM CODE	DESCRIPTION	QTY/CTN	PRICE
MK-SMS-5001	MASKI Respirator	36	21.60

**MK-SMS-5002
RESPO MASK RESPIRATOR***



- Respirator is consist of black comfortable rubber fitable facepiece Gray ABS cartridge holder.
- Adjustable elastic head strap reinforcement PE headband and anti-particulate per-filter, could fit in different cartridges by respirator as below.
- Anti-dust
- Anti-organic vapors
- Anti-ammonia

ITEM CODE	DESCRIPTION	QTY/CTN	PRICE
MK-SMS-5002	RESPO MASK Respirator	24	27.60

**MK-SMS-5003
RESPO CARTRIDGE***



ITEM CODE	DESCRIPTION	QTY/CTN	PRICE
MK-SMS-5003A	RESPO Cartridge Anti-Dust	120	9.70
MK-SMS-5003B	RESPO Cartridge Anti Organic Vapors	120	13.60
MK-SMS-5003C	RESPO Cartridge Anti Ammonia Gases	120	26.10

**MK-SMS-5004
DUSKEN RESPIRATOR***



- Particulate Respirator with valve.
- Against Non-toxic solid and liquid aerosols according to EN149:2001
- Loaded with high performance active carbon pre-filter against nuisance organic vapors.
- Exhalation Valve make breathing easier and reduce hot air built up.
- Latex free synthetic rubber head strap.
- Recommend application: Iron and steel industry, Hospital, Mine work, Underground civil engineering, Disease, etc.

ITEM CODE	DESCRIPTION	QTY/CTN	PRICE
MK-SMS-5004	DUSKEN Respirator	200	15.70

**MK-SMS-5005
BLOCNET RESPIRATOR***



- Particulate Respirator with valve.
- Valve Particulate Respirator.
- Against non-toxic solid and liquid aerosols according to EN149:2001
- Smooth PP Inner layers provides smooth lining and comfortable feeling.
- Low breathing resistance and long life time for use.
- Recommend application: Iron and steel industry, Hospital, Mine work, Underground civil engineering, Disease, etc.

ITEM CODE	DESCRIPTION	QTY/CTN	PRICE
MK-SMS-5005	BLOCNET Respirator	200	9.70

**MK-SMS-5006
PURAIR RESPIRATOR***



- PE frame covered by polyester fiber.
- With active carbon filter protection against toxic dust and filter out odors
- Active carbon filter is replaceable.

ITEM CODE	DESCRIPTION	QTY/CTN	PRICE
MK-SMS-5006	PURAIR Respirator	200	6.00

Courtesy - Stantec
MR. MARK
Professional Tool

**WE LOOK
WE LISTEN
WE CARE**



3S DYNAMICS PROFILE
SAFETY. STRENGTH. SERVICE



BIOHAZARD



RADIOACTIVE



**HIGHLY
FLAMMABLE**



POISON



**SLIPPERY
FLOOR**



DANGER



CAUTION



IRRITANT





THE PROFESSIONALS' CHOICE



www.mrmarks.com



info@mrmarks.com